



# GS1 General Specifications

## Version 9.0

*Issue 1, Jan-2009*



## Document Summary

Document Item	Current Value
Document Title	GS1 General Specifications, Version 9.0
Date Last Modified	Jan-2009
Current Document Issue	Issue 1
Status	Approved
Document Description (one sentence summary)	The GS1 General Specifications are the core standards document describing how barcodes and identification keys should be used to comply with GS1 standards. They are used throughout the GS1 System.

## Disclaimer

Whilst every effort has been made to ensure that the guidelines to use the GS1 standards contained in the document are correct, GS1 and any other party involved in the creation of the document HEREBY STATE that the document is provided without warranty, either expressed or implied, of accuracy or fitness for purpose, AND HEREBY DISCLAIM any liability, direct or indirect, for damages or loss relating to the use of the document. The document may be modified, subject to developments in technology, changes to the standards, or new legal requirements.

Several products and company names mentioned herein may be trademarks and/or registered trademarks of their respective companies.

## Log of Changes in Version 9.0

GSCN	Section	Summary of Change
08-0160	1	[Re-] Introduction in Section 1.4.3 of the summary of GS1 Prefixes and GTIN-8 Prefixes
08-0075 08-0162	2	Clarification on rules related to ISBN (International Standard Book Number) Improved navigation and correction of a number of references to GTIN-8 usage
08-0161 08-0166	3	Improve navigation by listing all Application Identifiers in numeric order. Removal of outdated references EPC-RFID
08-0147	4	Pointer to GLN Allocation Rules on <a href="http://www.gs1.org/glnrules">www.gs1.org/glnrules</a>
08-0012 08-0036 08-0162	5	New Appendix covering concatenation for any 'GS1 Symbologies using GS1 Application Identifiers' Correction of all GS1 DataBar Terminology. [Re-] Introduction and improved navigation around Symbology Specification Tables
07-0415 08-0166	6	Clarity on the use of more than one bar code symbol Removal of outdated references EPC-RFID
08-0075 08-0012 08-0161	7	Clarification on rules related to ISBN (International Standard Book Number) New Logic flow covering concatenation for any 'GS1 Symbologies using GS1 Application Identifiers' Improve navigation by listing all Application Identifiers details in Section 3.
08-0012 08-0036 08-0166	8	New definition for 'GS1 Symbologies using GS1 Application Identifiers' Correction of all GS1 DataBar Terminology Removal of outdated references EPC-RFID

## Who Should Read These Specifications

Technical experts working with the GS1 System should read these specifications. They provide a global reference document covering all technical aspects of the GS1 System. Their primary objective is to define the international standard upon which individual GS1 Member Organizations can develop user documentation.

## Electronic Data Interchange

The use of Electronic Data Interchange (EDI) is an integral part of the GS1 System philosophy. Full details on the EDI standards are contained in EANCOM and GS1 XML. EANCOM is an implementation guideline of the EDIFACT standards (Electronic Data Interchange for Administration, Commerce and Transport) developed under the auspices of the United Nations.

## Navigator

These specifications have been developed as a reference document aimed primarily at GS1 Member Organisations (who also produce local language user manuals) and system engineers developing software based upon GS1 System standards. All aspects of the GS1 System are summarized in Section 1, which is recommended for those wishing to become familiar with the GS1 System logic and terminology.

Each application section mandates the use of system features defined elsewhere in this document, such as Check Digits, Element Strings, data carriers, and bar code symbol placement.

The sections of these GS1 General Specifications are:

- **Section 1. Basics and Principles of the GS1 System:** Provides an introduction to the core components of the GS1 System
- **Section 2 Application Identification:** Provides a definition for each GS1 application using a template format. Each application is uniquely identified and contains a description, the associated GS1 Key, its definition and links to relevant data structures and attributes (Section 3), rules (Section 4), carrier specifications (Section 5), placement (section 6), and unique processing requirements (Section 7).
- **Section 3 GS1 Application Identifier Definitions:** Describes the meaning, structure, and function of the GS1 element strings so they can be correctly processed in users' application programs
- **Section 4 Application Rules:** Provides the rules for use of GS1 Keys in their application environments. Differences in industries are included as well as the data relationship rules for Application Identifier use.
- **Section 5 Data Carriers:** Provides a detailed description of the data carriers that are endorsed by GS1. It includes symbol specification tables for use in the supply chain operational environment as well as the related bar code production and quality assessment required to achieve excellent scan rates.
- **Section 6 Symbol Placement Guidelines:** Provides guidance on symbol placement as well as transport label standards and tag standards
- **Section 7 AIDC Validation Rules:** Provides rules for validating and processing GS1 Element Strings without human intervention. Check digit and calendar date algorithms are also included.
- **Section 8 GS1 Standards Glossary of Terms:** A standard vocabulary used throughout the GS1 System

# Table of Contents

<b>Section 1. Basics and Principles of the GS1 System .....</b>	<b>11</b>
1.1. The GS1 General Specifications .....	12
1.1.1. Introduction .....	12
1.1.2. Who Should Read These Specifications .....	12
1.1.3. Foundational Standards .....	13
1.1.4. Maintenance Responsibility and Management .....	13
1.1.5. The BarCodes and Identification Requirements Group (BRG) .....	13
1.1.6. BarCodes and Identification Business Unit .....	13
1.1.7. The BarCodes Technology Group (BTG) .....	13
1.2. GS1 System Principles .....	13
1.2.1. Open Standards .....	14
1.2.2. Differentiation .....	14
1.2.3. Transparency .....	14
1.2.4. Non-Significance .....	14
1.3. Identification System Policies .....	14
1.3.1. Mandatory Identifiers .....	14
1.3.2. Non-GS1 Identifiers .....	14
1.3.3. GS1 Company Prefix .....	14
1.3.4. Carrier Independence .....	15
1.3.5. GS1 Business Messages .....	15
1.4. GS1 Prefixes and GS1 Company Prefixes .....	15
1.4.1. Global, Open Versus Restricted .....	15
1.4.2. GS1 Prefixes .....	16
1.4.3. GS1 Company Prefix .....	17
1.5. GS1 Company Prefix Allocation .....	17
1.6. Allocation .....	17
1.6.1. Acquisitions and Mergers .....	17
1.7. Sunrise and Sunset Dates .....	18
<b>Section 2. Application Identification .....</b>	<b>19</b>
2.1. Trade Items .....	20
2.1.1. Introduction .....	20
2.1.2. Fixed Measure Trade Items – Open Supply Chain .....	21
2.1.3. Fixed Measure – Very Small Healthcare Items .....	38
2.1.4. Fixed Measure – Trade Items Packed in Several Physical Units NOT Scanned at POS .....	39
2.1.5. Fixed Measure - Direct Part Marking .....	40
2.1.6. Variable Measure Trade Items Not Crossing a Point-of-Sale .....	45
2.1.7. Fixed Measure – Restricted Distribution .....	53
2.1.8. Identification of Variable Measure Trade Items – Restricted Circulation .....	60
2.2. Numbering and Marking of Logistic Units .....	62
2.2.1. Individual Logistic Units .....	63
2.2.2. Multiple Logistic Units – Consignment Number .....	64
2.2.3. Multiple Logistic Units – Shipment Number .....	65
2.3. Assets .....	66
2.3.1. Global Returnable Asset Identifier (GRAI): AI (8003) .....	66

- 2.3.2. Global Individual Asset Identifier (GIAI): AI (8004).....68
- 2.4. Locations ..... 69
  - 2.4.1. Introduction .....69
  - 2.4.2. EDI and Global Data Synchronization (GDS) .....70
  - 2.4.3. Application Overview .....70
  - 2.4.4. Global Location Number to Identify a Physical Location: AI (414) .....71
  - 2.4.5. Ship to – Deliver to Global Location Number: AI (410) .....73
  - 2.4.6. Bill to - Invoice to Global Location Number: AI (411) .....74
  - 2.4.7. Purchased from Global Location Number: AI (412) .....74
  - 2.4.8. Ship for - Deliver for - Forward to Global Location Number: AI (413).....75
  - 2.4.9. Global Location Number of the Invoicing Party: AI (415) .....77
- 2.5. Numbering and Symbol Marking of Service Relationships..... 78
- 2.6. Numbering and Symbol Marking for Special Applications ..... 80
  - 2.6.1. Coupons .....80
  - 2.6.2. Allocating GS1 System Coupon Data .....80
  - 2.6.3. Coupon Identification for Restricted Geographic Distribution (GS1 Prefix 99) .....81
  - 2.6.4. GS1 Common Currency Coupon Identification (GS1 Prefixes 981 and 982).....82
  - 2.6.5. GS1 US Coupon Code Identification for Use in North America (U.P.C. Prefix 5) .....84
  - 2.6.6. GS1 US Coupon Extended Bar Code: AI (8100 - 8102) .....86
  - 2.6.7. Coupon Code Identification for Use in North America (AI 8110).....87
  - 2.6.8. Refund Receipts .....87
  - 2.6.9. Electronic Serial Identifier for Cellular Mobile Telephones (CMTI): AI (8002) .....89
  - 2.6.10. Numbering and Symbol Marking for Payment Slips.....90
  - 2.6.11. Customer Specific Articles .....93
  - 2.6.12. Custom Trade Item .....97
  - 2.6.13. Global Document Type Identifier (Numbering & Symbol Marking for Document Control).....100

**Section 3. GS1 Application Identifier Definitions .....106**

- 3.1. Introduction..... 107
- 3.2. GS1 Application Identifiers in Numerical Order ..... 107
- 3.3. GS1 Application Identifiers starting with digit 0..... 112
  - 3.3.1. Identification of a Logistic Unit: AI (00).....112
  - 3.3.2. Identification of a Fixed Measure Trade Item (GTIN): AI (01) .....112
  - 3.3.3. Identification of a Variable Measure Trade Item (GTIN): AI (01).....113
  - 3.3.4. Identification of Fixed Measure Trade Items Contained in a Logistic Unit: AI (02).....113
  - 3.3.5. Identification of Variable Measure Trade Items Contained in a Logistic Unit: AI (02) .....114
- 3.4. GS1 Application Identifiers starting with digit 1 ..... 115
  - 3.4.1. Batch or Lot Number: AI (10) .....115
  - 3.4.2. Production Date: AI (11) .....115
  - 3.4.3. Due Date for Amount on Payment Slip: AI (12) .....116
  - 3.4.4. Packaging Date: AI (13).....116
  - 3.4.5. Best Before Date: AI (15).....117
  - 3.4.6. Expiration Date: AI (17).....118
- 3.5. GS1 Application Identifiers starting with digit 2..... 118
  - 3.5.1. Product Variant: AI (20) .....118
  - 3.5.2. Serial Number: AI (21) .....119
  - 3.5.3. Secondary Data for Specific Health Industry Products: AI (22).....119
  - 3.5.4. Additional Product Identification Assigned by the Manufacturer: AI (240).....119

3.5.5.	Customer Part Number: AI (241) .....	120
3.5.6.	Made-to-Order Variation Number: AI (242).....	120
3.5.7.	Secondary Serial Number: AI (250) .....	121
3.5.8.	Reference to Source Entity: AI (251) .....	122
3.5.9.	Global Document Type Identifier (GDTI): AI (253).....	122
3.5.10.	GLN Extension Component: AI (254).....	123
3.6.	GS1 Application Identifiers starting with digit 3.....	123
3.6.1.	Variable Count: AI (30) .....	123
3.6.2.	Trade Measures: AIs (31nn, 32nn, 35nn, 36nn) .....	124
3.6.3.	Logistic Measures: AIs (33nn, 34nn, 35nn, 36nn).....	125
3.6.4.	Kilograms Per Square Metre: AI (337n) .....	127
3.6.5.	Count of Trade Items Contained in a Logistic Unit: AI (37) .....	127
3.6.6.	Amount Payable - Single Monetary Area: AI (390n) .....	128
3.6.7.	Amount Payable and ISO Currency Code: AI (391n).....	128
3.6.8.	Amount Payable for a Variable Measure Trade Item – Single Monetary Area: AI (392n) .....	129
3.6.9.	Amount Payable for a Variable Measure Trade Item and ISO Currency Code: AI (393n) .....	130
3.7.	GS1 Application Identifiers starting with digit 4.....	131
3.7.1.	Customer's Purchase Order Number: AI (400) .....	131
3.7.2.	Consignment Number: AI (401) .....	131
3.7.3.	Shipment Identification Number: AI (402) .....	132
3.7.4.	Routing Code: AI (403) .....	133
3.7.5.	Ship to - Deliver to Global Location Number: AI (410) .....	133
3.7.6.	Bill to - Invoice to Global Location Number: AI (411) .....	134
3.7.7.	Purchased from Global Location Number: AI (412) .....	134
3.7.8.	Ship for - Deliver for - Forward to Global Location Number: AI (413).....	135
3.7.9.	Identification of a Physical Location - Global Location Number: AI (414).....	135
3.7.10.	Global Location Number of the Invoicing Party: AI (415) .....	136
3.7.11.	Ship to - Deliver to Postal Code within a Single Postal Authority: AI (420) .....	136
3.7.12.	Ship to - Deliver to Postal Code with Three-Digit ISO Country Code: AI (421) .....	137
3.7.13.	Country of Origin of a Trade Item: AI (422).....	137
3.7.14.	Country of Initial Processing: AI (423).....	138
3.7.15.	Country of Processing: AI (424).....	138
3.7.16.	Country of Disassembly: AI (425) .....	139
3.7.17.	Country Covering Full Process Chain: AI (426) .....	139
3.8.	GS1 Application Identifiers starting with digit 7 .....	140
3.8.1.	Seventy Series AIs - Cautionary Note.....	140
3.9.	GS1 Application Identifiers starting with digit 8.....	143
3.9.1.	Roll Products - Width, Length, Core Diameter, Direction, Splices: AI (8001).....	143
3.9.2.	Cellular Mobile Telephone Identifier: AI (8002).....	143
3.9.3.	Global Returnable Asset Identifier (GRAI): AI (8003).....	144
3.9.4.	Global Individual Asset Identifier (GIAI): AI (8004).....	144
3.9.5.	Price per Unit of Measure: AI (8005).....	145
3.9.6.	Identification of the Components of a Trade Item: AI (8006).....	145
3.9.7.	International Bank Account Number (IBAN): AI (8007) .....	146
3.9.8.	Date and Time of Production: AI (8008).....	146
3.9.9.	Global Service Relation Number (GSRN): AI (8018) .....	147
3.9.10.	Payment Slip Reference Number: AI (8020).....	148
3.9.11.	GS1-128 Coupon Extended Bar Code: AIs (8100 - 8102) .....	148



- 3.9.12. Coupon Code Identification for Use in North America (AI 8110) ..... 149
- 3.10. GS1 Application Identifiers starting with digit 9 ..... 149
  - 3.10.1. Information Mutually Agreed Between Trading Partners (Including FACT Data Identifiers): AI (90) .... 149
  - 3.10.2. Company Internal Information: AIs (91 - 99) ..... 150
- 3.11. Compatibility of EPCglobal Tag Data Standard and GS1 General Specifications ..... 150

**Section 4. Application Rules ..... 151**

- 4.1. Introduction ..... 152
- 4.2. Rules for Keys ..... 152
  - 4.2.1. GTIN Rules ..... 152
  - 4.2.2. SSCC Rules ..... 153
  - 4.2.3. Assets Rules ..... 153
  - 4.2.4. GLN Rules ..... 153
- 4.3. GTIN Rules ..... 154
  - 4.3.1. Allocating the Numbers ..... 154
- 4.4. SSCC Rules ..... 161
  - 4.4.1. Allocating Serial Shipping Container Codes ..... 161
- 4.5. Allocating GS1 System Asset Identifiers ..... 162
  - 4.5.1. General Rule ..... 162
  - 4.5.2. Change of Asset Ownership ..... 163
  - 4.5.3. Information Associated with Asset Identifiers ..... 164
- 4.6. GLN Rules ..... 164
  - 4.6.1. Allocating Global Location Numbers ..... 164
  - 4.6.2. Information Associated with a Global Location Number ..... 166
  - 4.6.3. GLN Allocation Rules ..... 166
- 4.7. GSRN Rules ..... 166
  - 4.7.1. Allocating Global Service Relation Numbers ..... 166
  - 4.7.2. General Rule ..... 166
- 4.8. GDTI Rules ..... 167
  - 4.8.1. Application Rules ..... 167
- 4.9. Data Relationships ..... 169
  - 4.9.1. Invalid Pairs of Element Strings ..... 169
  - 4.9.2. Mandatory Association of Element Strings ..... 170

**Section 5. Data Carriers ..... 173**

- 5.1. Introduction ..... 174
  - 5.1.1. International Standards ..... 175
  - 5.1.2. Symbology Identifiers ..... 176
- 5.2. Linear Bar Codes - EAN/UPC Symbology Specifications ..... 177
  - 5.2.1. EAN/UPC Symbology Specifications ..... 177
  - 5.2.2. Symbology Characteristics ..... 177
  - 5.2.3. Reference Decode Algorithm ..... 189
  - 5.2.4. Human Readable Interpretation ..... 192
- 5.3. Linear Bar Codes - ITF-14 Symbology Specifications ..... 201
  - 5.3.1. Symbology Characteristics ..... 201
- 5.4. Linear Bar Codes - GS1-128 Symbology Specifications ..... 209
  - 5.4.1. GS1-128 Symbology Characteristics ..... 209

5.4.2.	GS1-128 Bar Code Symbol Structure .....	210
5.4.3.	GS1-128 Symbology Character Assignments.....	211
5.4.4.	Dimensional Requirements .....	219
5.4.5.	Reference Decode Algorithm .....	219
5.4.6.	Symbol Quality.....	222
5.4.7.	GS1-128 Symbology Application Parameters .....	223
5.5.	Bar Code Production and Quality Assessment.....	227
5.5.1.	Introduction .....	227
5.5.2.	GS1 System Symbol Specification Tables.....	227
5.5.3.	Bar Code Production.....	239
5.6.	Linear Bar Codes – GS1 DataBar (Formerly RSS).....	262
5.6.1.	GS1 DataBar (Formerly RSS).....	262
5.7.	Two Dimensional Bar Codes – GS1 DataMatrix Symbology.....	271
5.7.1.	Introduction .....	271
5.7.2.	GS1 DataMatrix Features and Symbol Basics .....	272
5.7.3.	GS1 DataMatrix Symbology.....	273
5.8.	Composite Bar Codes .....	278
5.8.1.	Composite Symbology Introduction .....	278
5.8.2.	Symbol Structure .....	279
5.8.3.	Human Readable Interpretation of Composite Symbols .....	285
5.8.4.	Data Transmission and Symbology Identifier Prefixes.....	286
5.8.5.	Width of a Module (X) .....	287
5.8.6.	Print Quality .....	287
5.8.7.	Advice for Selecting a Symbology.....	287
5.8.8.	Sample Composite Symbols .....	288
5.9.	Appendix: Rules for Encoding/Decoding Element Strings in GS1 Symbologies using GS1 Application Identifiers .....	291
5.9.1.	The Basic Structure of GS1 Bar Code Symbols using GS1 Application Identifiers and Concatenation.....	291
5.9.2.	Concatenation of the Pre-Defined Length Element Strings.....	292

## **Section 6. Symbol Placement Guidelines .....295**

6.1.	Introduction.....	296
6.2.	General Placement Principles.....	296
6.2.1.	Number of Symbols .....	296
6.2.2.	Scanning Environment.....	296
6.2.3.	Orientation .....	296
6.3.	General Placement Guidelines for Point-of-Sale .....	300
6.3.1.	Number of Symbols .....	300
6.3.2.	Identifying the Back of the Trade Item .....	301
6.3.3.	Symbol Placement.....	301
6.4.	Placement Guidelines for Specific Package Types .....	305
6.4.1.	Bags.....	307
6.4.2.	Blister Packs.....	307
6.4.3.	Bottles and Jars .....	308
6.4.4.	Boxes.....	309
6.4.5.	Cans and Cylinders.....	310
6.4.6.	Carded Items .....	310
6.4.7.	Egg Cartons.....	311

6.4.8.	Jugs .....	312
6.4.9.	Large, Heavy, or Bulky Items .....	312
6.4.10.	Multipacks .....	315
6.4.11.	Publishing Items.....	315
6.4.12.	Thin Items or Containers.....	317
6.4.13.	Trays.....	318
6.4.14.	Tubes.....	318
6.4.15.	Tubs.....	319
6.4.16.	Unpackaged Items .....	320
6.4.17.	Sets (Grouping of Individually Bar Coded Items) .....	322
6.4.18.	Sporting Goods.....	323
6.4.19.	Textured Surfaces.....	334
6.5.	Symbol Placement for Clothing and Fashion Accessories .....	334
6.5.1.	Information Zones Concept.....	335
6.5.2.	Hangtag (Hanging Label) Format.....	336
6.5.3.	Sewn-On (Joker) Label Format.....	338
6.5.4.	Sewn-In Label Formats.....	340
6.6.	Plastic Packaged Products Label Location Guidelines.....	341
6.6.2.	Boxed Products Label Formats.....	343
6.6.3.	Banded Products Label Formats.....	346
6.7.	GS1 Logistics Label Design .....	348
6.7.1.	Scope.....	348
6.7.2.	Concepts.....	348
6.7.3.	Label Design.....	349
6.7.4.	Technical Specifications .....	350
6.7.5.	Label Examples .....	351
6.7.6.	EPCglobal Seal Application Guidelines .....	355
6.8.	Placement Labels Used in General Distribution .....	355
6.8.1.	General Rule.....	356
6.8.2.	Recommendation to Include a Bar Code on Two Sides.....	358
6.8.3.	Add-On Symbols.....	359
<b>Section 7.</b>	<b>AIDC Validation Rules.....</b>	<b>360</b>
7.1.	Introduction.....	361
7.2.	Synopsis of Message Processing .....	362
7.2.1.	Analysis of the Data Carrier and Plausibility Test for Element Strings .....	363
7.2.2.	Symbology Identification .....	364
7.2.3.	Prefix in Internal Table .....	364
7.2.4.	Item Identification.....	364
7.2.5.	Application Identifier (AI) in Internal Table .....	364
7.2.6.	Length of Data 14 Digits .....	364
7.2.7.	Check Digit Calculation and other system checks .....	364
7.2.8.	Move Element String to Message Field .....	365
7.3.	Validation of the Electronic Message Regarding System Consistency .....	365
7.4.	Validation of the Electronic Message Regarding User Requirements.....	366
7.5.	Conversion of Weights and Measures in User Applications .....	367
7.6.	Linkage of GTINs in a Database .....	368
7.6.1.	The Principle.....	369



- 7.6.2. Extended Example of a Trade Item Hierarchy .....369
- 7.6.3. Linkage of GTINs in a Non-Relational Database by Trade Item Manufacturer .....370
- 7.7. Elements Strings Represented in Data Carriers ..... 371
  - 7.7.1. Element Strings Represented in GS1 System Data Carriers .....372
  - 7.7.2. Element Strings Represented in a GS1 Symbology using GS1 Application Identifiers .....373
- 7.8. Secondary Data for specific Health Industry Products ..... 373
- 7.9. Processing of Data from a GS1 Symbology using GS1 Application Identifiers ..... 375
  - 7.9.1. General .....376
  - 7.9.2. Element Strings with Pre-Defined Lengths Using Application Identifiers .....376
  - 7.9.3. The Function 1 Symbol Character (FNC1).....376
- 7.10. Check Digit Calculations ..... 377
  - 7.10.1. Standard Check Digit Calculations for GS1 Data Structures .....377
  - 7.10.2. Check Digit Calculation for Price/Weight Fields .....377
  - 7.10.3. Check Digit Calculation for the Four-Digit Price Field .....379
  - 7.10.4. Check Digit Calculation for the Five-Digit Price Field.....379
- 7.11. GTIN-12 and RCN-12 in a UPC-E Bar Code Symbol..... 380
- 7.12. The International Standard ISO/IEC 646 ..... 382
- 7.13. Determination of Century in Dates..... 383
- Section 8. GS1 Standards Glossary of Terms .....384**
  - 8.1. GS1 Glossary Terms and Definitions..... 385
  - 8.2. GS1 Abbreviations ..... 396
  - 8.3. Legacy (Retired) Terms ..... 397



# **Section 1. Basics and Principles of the GS1 System**

- The GS1 General Specifications
- GS1 System Principles
- Identification System Policies
- GS1 Prefixes and GS1 Company Prefixes
- GS1 Company Prefix Allocation
- Allocation
- Sunrise and Sunset Dates

Whilst every effort has been made to ensure that the guidelines to use the GS1 standards contained in the document are correct, GS1 and any other party involved in the creation of the document HEREBY STATE that the document is provided without warranty, either expressed or implied, of accuracy or fitness for purpose, AND HEREBY DISCLAIM any liability, direct or indirect, for damages or loss relating to the use of the document. The document may be modified, subject to developments in technology, changes to the standards, or new legal requirements.

Several products and company names mentioned herein may be trademarks and/or registered trademarks of their respective companies.

## 1.1. The GS1 General Specifications

### 1.1.1. Introduction

The GS1 System originated in the United States and was established in 1973 by the Uniform Product Code Council, known until recently as the Uniform Code Council, Inc. (UCC) and since 2005 as GS1 US. The UCC originally adopted a 12-digit identification number, and the first ID numbers and bar code symbols in open trade were being scanned in 1974. Following the success of this U.P.C. System, the European Article Numbering Association, previously known as EAN International, but launched as GS1 in 2005, was established in 1977 to develop a compatible system for use outside North America. The EAN System was designed as a superset of the UCC System and principally used 13-digit numbers. As a consequence of using certain bar code symbols and data structures, the GS1 System has expanded.

The GS1 System provides for the use of unambiguous numbers to identify goods, services, assets, and locations worldwide. These numbers can be represented in bar code symbols to enable their electronic reading wherever required in business processes. The system is designed to overcome the limitations of using company, organisation, or sector specific coding systems, and to make trading much more efficient and responsive to customers.

These identification numbers are also used in Electronic Data Interchange (EDI), XML electronic messaging, Global Data Synchronization (GDSN), and GS1 Network Systems. This document provides information about syntax, assignment, allocation and Automatic Data Capture (ADC) standards for GS1 identification numbers.

In addition to providing unique identification numbers, the GS1 System provides for supplementary information, such as best before dates, serial numbers, and batch numbers, which can appear in bar code symbol form. Currently, bar code symbols are used as the data carriers, but other technologies, such as radio frequency tags are being developed within EPCglobal as carriers of GS1 data. Changes take place only after wide consultation and are subject to a significant migration period.

By following the principles and design of the GS1 System, users can design applications to process GS1 System data automatically. The system logic guarantees that data captured from GS1 endorsed bar code symbols produces unambiguous electronic messages, and processing can be fully pre-programmed.

The GS1 System is designed for use in any industry or trade sector, and any changes to the system are introduced so as not to negatively affect current users.

In February 2005, GS1 was officially launched as the successor to the organisations previously known as EAN and UCC. This document is the concise definition and explanation of the use of the GS1 System standards within Automatic Identification and Data Capture (AIDC) technologies, and supersedes all previous AIDC technical documents provided and/or published by GS1 or its predecessor organisations. The document takes immediate effect as the agreed GS1 foundational standards including Application, Identification, and Data Carrier components and principles. Every organisation using GS1 System standards is requested to conform fully to the *GS1 General Specifications*.

### 1.1.2. Who Should Read These Specifications

The primary audiences of the *GS1 General Specifications* are GS1 Member Organisations and technically oriented users and suppliers.

These specifications provide a global reference document covering all technical aspects of the GS1 System. Their primary objective is to define the international standard upon which individual GS1 Member Organisations can develop user documentation. They are maintained in English and translated into local language by Member Organisations.

### 1.1.3. Foundational Standards

These *GS1 General Specifications* are the foundation for GS1 Electronic Messaging:

- Electronic Data Interchange (EDI)
- XML
- GDSN
- Net Solutions

The definitions in the *GS1 General Specifications* are the foundation of the GS1 Global Data Dictionary.

### 1.1.4. Maintenance Responsibility and Management

The GS1 Global Standards Management Process (GSMP) is the mechanism to approve the adoption of additions and changes to the *GS1 General Specifications*. The process is fully defined in the *Global Standards Management Process Manual*.

### 1.1.5. The BarCodes and Identification Requirements Group (BRG)

The BarCodes and Identification Requirements Group (BRG) approves simple change requests to the *GS1 General Specifications* and resolves complex change requests by co-chairing work groups established for individual change requests (e.g., new data carriers; new identification structures; Automatic Identification and Data Capture (AIDC) attributes; specifications for carrier quality, performance, and related ergonomic factors).

### 1.1.6. BarCodes and Identification Business Unit

The BarCodes and Identification Business Unit co-ordinates work plans and projects with:

- BarCodes and Identification Requirements Group
- Related work groups
- Other GS1 Business Units BarCodes Business Units and GS1 Management
- BarCodes Technology Group

### 1.1.7. The BarCodes Technology Group (BTG)

The BarCodes Technology Group (BTG) provides advice and guidance from the solution provider community regarding practical implementation issues and technical applications. In addition, BTG provides expertise for testing and trial implementations.

## 1.2. GS1 System Principles

The GS1 System embodies an open architecture approach. It has been carefully designed for modular expansion with minimal disruption to existing applications. Enterprise Resource Planning (ERP) and other supply chain application software drive implementation of the system. New user driven applications can be expected, and this document will be updated accordingly.

The maintenance of these specifications will be the responsibility of GS1 and will incorporate the four principles of the GS1 System: Open Standards, Differentiation, Transparency, and Non-Significance.

### 1.2.1. Open Standards

This principle involves achieving a single, open, business led integrated system of identification and information transfer technology standards that enables effective supply chain management in any company and any industry anywhere in the world.

### 1.2.2. Differentiation

The GS1 System is founded on rules-based standards that ensure globally unique and discrete identification of such things as products, handling units, assets, and locations. The system includes standard ways to transfer GS1 System identification numbers as well as relevant data related to these numbers.

### 1.2.3. Transparency

GS1 System identification numbers must be relevant and applicable to any supply chain, independent of who assigns, receives, and processes the standards. This should enable only one way to perform any given function. New features should only be introduced to the standard if they enable new applications or better ways to perform existing functions.

### 1.2.4. Non-Significance

The GS1 System provides data structures for different applications. The application will determine how the number is to be used, but regardless of application, each number must be used in its entirety and not broken into constituent parts. The data structure guarantees worldwide uniqueness within the relevant area of application.

## 1.3. Identification System Policies

The GS1 identification system provides the world a globally unique and unambiguous identification system for physical entities, parties, and relationships exchanged in the supply chain. The policies that follow apply to all sectors making use of the GS1 Company Prefix in association with GS1 Keys and the Application Identification System. These policies provide for the long term integrity of the GS1 identification system so vital to the global supply.

### 1.3.1. Mandatory Identifiers

All GS1 standards shall incorporate GS1 identification standards as mandatory identifiers exclusive of all other mandatory identifiers.

### 1.3.2. Non-GS1 Identifiers

Non-GS1 identifiers may only be used with GS1 standards as additional identifiers (not alternates).

Implementations using non-GS1 identifiers as primary identifiers are not compliant with GS1 standards.

### 1.3.3. GS1 Company Prefix

The GS1 Company Prefix is used exclusively within GS1 identification standards that may be expressed in GS1 approved bar code applications, in GS1 eCom messages, for global data synchronization, network registration, and in EPC Tags within the header values reserved for the GS1 system.


### 1.3.4. Carrier Independence

GS1 Identification Keys are defined and utilized per GS1 definitions independent of data carrier (e.g., bar code, Radio Frequency Identification (RFID), business message).

### 1.3.5. GS1 Business Messages

GS1 business messages or GS1 standards-based applications use GS1 Identification Keys for identification exclusive of GS1 data carrier features. Examples of data carrier features include use of:

- Modulo 103 GS1-128 Symbol Check Character to secure data capture
- Function 1 Symbol Character (FNC1) in the second position of GS1-128 Bar Code Symbol or an Electronic Product Code (EPC) header value to discriminate between GS1 data content and data carrier overhead
- FNC1 as separator character or EPC parsing value to parse a decoded data string into significant data parts

 **Exception:** If an EPC user is using GS1 System and non-GS1 System headers to support an application, this policy does not apply, and advice should be sought on the use of EPC headers to provide uniqueness among multiple numbering systems.

## 1.4. GS1 Prefixes and GS1 Company Prefixes

### 1.4.1. Global, Open Versus Restricted

#### 1.4.1.1. Global, Open Numbers (Unrestricted Distribution)

Global, Open is an identification number used in unrestricted distribution which signifies that such system data may be applied on goods to be processed anywhere in the world without restraint as to such things as country, company, and industry.

#### 1.4.1.2. Restricted Circulation Numbers

Restricted Circulation Numbers are GS1 identification numbers used for special applications in restricted environments, defined by the local GS1 Member Organisation (e.g., restricted within a country, company, or industry). They are allocated by GS1 for either internal use by companies or to GS1 Member Organisations for assignment based on business needs in their country (e.g., Variable Measure Trade Item identification, coupons).

- RCN-12 is a 12-digit Restricted Circulation Number
- RCN-13 is a 13-digit Restricted Circulation Number
- RCN-8 is an 8-digit Restricted Circulation Number beginning with GS1-8 Prefix 0 or 2.

A Variable Measure Number identifies Variable Measure Trade Items for scanning at the Point of Sale. It is defined per GS1 Member Organisation rules.

- VMN-12 is a 12-digit Restricted Circulation Number encoded in UPC-A Symbols to allow scanning of Variable Measure Trade Items at the Point-of-Sale. It is defined per target market specific rules that are associated with U.P.C. Prefix 2.
- VMN-13 is a 13-digit Restricted Circulation Number encoded in EAN-13 Symbols to allow scanning of Variable Measure Trade Items at the Point-of-Sale. It is defined per target market specific rules that are associated with GS1 Prefixes 20 through 29.

### 1.4.2. GS1 Prefixes


The GS1 Prefix is a number with two or more digits, administered by the GS1 Global Office, which is allocated to GS1 Member Organisations or for Restricted Circulation Numbers. The main purpose of the GS1 Prefix is to allow decentralisation of the administration of identification numbers.

GS1 Prefixes are shown in Figures 1.4.2 – 1 and 1.4.2 – 2

**Figure 1.4.2 – 1**

Synopsis of GS1 Prefixes	
GS1 Prefixes	Significance
000 - 019	GS1 Prefix* (used to create U.P.C. Company Prefixes)
02	GS1 Variable Measure Trade Item identification for restricted distribution
030 - 039	GS1 Prefix
04	GS1 restricted circulation number within a
05	GS1 US coupon identification
060 - 099	GS1 Prefix (used to create U.P.C. Company Prefixes)
100 - 139	GS1 Prefix
140 - 199	Reserve
20 - 29	GS1 restricted circulation number within a geographic region
300 - 969	GS1 Prefix
970 - 976	Reserve
977	ISSN standard numbering (serial publications)
978 - 979	ISBN standard numbering (books)
980	GS1 identification of Refund Receipts
981-984	GS1 coupon identification for common currency areas
985 - 989	Reserved for further GS1 coupon identification
99	GS1 coupon identification

\* Starting from GS1 Company Prefix 00 00100 to avoid collision with GTIN-8 Identification Numbers.

 **Note:** GS1 Company Prefixes 00 00000 and 00 01000 to 00 07999 have specific application for Locally Assigned Codes (LACs) or Retailer Zero-Suppressed Codes (RZSCs).

**Figure 1.4.2 – 2**

Synopsis of GS1-8 Prefixes	
GS1-8 Prefixes	Significance
0	Velocity Codes
100 - 139	GS1 Prefix
140 - 199	Reserve
2	GS1 restricted circulation number within a company
300 - 969	GS1 Prefix
97 - 99	Reserve

### 1.4.3. GS1 Company Prefix

The GS1 Company Prefix is a part of GS1 data structures. It consists of a GS1 Prefix, which is administered by GS1, and a Company Number, which is assigned by a GS1 Member Organisation.

## 1.5. GS1 Company Prefix Allocation

A GS1 Company Prefix gives access to all the applications using GS1 System identification standards. A GS1 Company Prefix assigned to a member of any Member Organisation entitles that member to create any of the GS1 Identification Keys:

- Global Trade Item Number (GTIN)
- Global Location Number (GLN)
- Serial Shipping Container Code (SSCC)
- Global Returnable Asset Identifier (GRAI)
- Global Individual Asset Identifier (GIAI)
- Global Service Relation Number (GSRN)
- Global Document Type Identifier (GDTI)
- Any other GS1 data element that derives from a GS1 Company Prefix (e.g., consignment number, shipment number)

## 1.6. Allocation

The normal requirements on the re-use of GS1 identification numbers apply to all organisations at all times. The additional guidelines in the following sections apply when a company changes legal status as a result of an acquisition, merger, partial purchase, split, or “spin-off.”

GS1 Member Organisations may adapt the following guidelines if the law of the country makes it absolutely necessary.

Companies should notify their GS1 Member Organisation of any legal status change within one year of that change to facilitate a smooth transition.

### 1.6.1. Acquisitions and Mergers

If a company is being acquired by or merged with another company and has stock on hand, the stock's existing Global Trade Item Numbers (GTINs) should be kept. Products that are produced after the acquisition or merger may keep the GTIN allocated before the acquisition if the acquiring company maintains the GS1 Member Organisation membership.

A merger implies that someone has taken over a company and has assumed responsibility for the company's GS1 Company Prefix as well as their assets and locations. Products that the acquired company produced under its GS1 Company Prefix can still be produced using the same prefix after the merger, since the acquiring company has control of the acquired company's GS1 Company Prefix.

If it so desires, the acquiring company can label all acquired products using their existing GS1 Company Prefix. The importance of ensuring trading partners are informed of any changes in a timely manner cannot be overemphasized. A company should be careful when centralizing the allocation of all numbers under one GS1 Company Prefix, thus changing the GTIN of the existing products, which are otherwise unchanged. Centralizing the allocation of all numbers under a single GS1 Company Prefix should be an exception, as it results in additional work and data file maintenance for customers.

### 1.6.1.1. Partial Purchase

If a company purchases a division of a company whose GS1 Company Prefix is used in divisions not purchased, then the acquiring company must change the Global Trade Item Numbers (GTINs) for products in the purchased division as well as any related Global Location Numbers (GLNs), within one year.

The rules concerning the use of the seller's GTINs and other GS1 Identification Keys should be taken into consideration when drawing up the purchase contract.

At the earliest opportunity, the buyer should phase in new numbers from its own range of numbers for items whose brand name it has acquired. The buyer will be able to do this, for example, when packaging is redesigned or reprinted.

If a company sells an asset to another company, then the asset identifier should ideally be replaced by another Global Individual Asset Identifier (GIAI) or Global Returnable Asset Identifier (GRAI) within one year or be removed from the physical item.

During a company sale and for four years following the selling company must not reallocate the original numbers to other items.

### 1.6.1.2. Split or Spin-Off

When a company splits into two or more separate companies it is necessary for each GS1 Company Prefix assigned to the original company to be transferred to only one of the new companies. Any company left without a GS1 Company Prefix will need to apply to a GS1 Member Organisation to obtain one. The decision about which of the new companies should take the original GS1 Company Prefixes should be made in such a way as to minimize the number of additional Global Trade Item Numbers (GTINs) required. The decision should be part of the legal arrangements of the new companies.

It is not necessary for existing stocks of items to be renumbered. However, when any of the split or spin-off companies has trade items that are numbered with a GS1 Company Prefix that it no longer holds, the company should renumber those items using its own GS1 Company Prefix when new labelling or packaging is produced. Customers should be notified well in advance of the changes.

Split or spin-off companies that retain a GS1 Company Prefix must keep a record of the GTINs created that have been allocated to items they no longer own. They must not re-use these GTINs for a period of at least four years after the company that split away owning those items last supplied goods identified by those GTINs. Therefore, the company that did not retain the GS1 Company Prefix has to keep the company that now maintains it informed of the dates on which goods were last supplied using that GS1 Company Prefix or to guarantee a date by which the number change will be made.

## 1.7. Sunrise and Sunset Dates

Expansion of both the breadth and reach of the GS1 system requires the introduction of new data carrier technologies and messaging techniques. While these are potentially disruptive, their use in GS1 Global, Open standards requires an agreed date at which they are globally accepted for use. This date is referred to as a Sunrise Date. Its use is accompanied by associated rules that may be unique to the circumstances. A Sunrise Date is agreed by user/members and approved by the GS1 Management Board.

Conversely, as a data carrier or messaging standard is no longer cost effective as determined by users and approved by the GS1 Management Board, it may be declared obsolete and removed from the *GS1 General Specifications*. This is termed the Sunset Date. It is accompanied by associated rules that may be unique to the circumstances.



## Section 2. Application Identification

- Trade Items
- Numbering and Marking of Logistic Units
- Assets
- Locations
- Numbering and Symbol Marking of Service Relationships
- Numbering and Symbol Marking for Special Applications

Whilst every effort has been made to ensure that the guidelines to use the GS1 standards contained in the document are correct, GS1 and any other party involved in the creation of the document HEREBY STATE that the document is provided without warranty, either expressed or implied, of accuracy or fitness for purpose, AND HEREBY DISCLAIM any liability, direct or indirect, for damages or loss relating to the use of the document. The document may be modified, subject to developments in technology, changes to the standards, or new legal requirements.

Several products and company names mentioned herein may be trademarks and/or registered trademarks of their respective companies.

## 2.1. Trade Items

### 2.1.1. Introduction

A trade item is any item (product or service) upon which there is a need to retrieve pre-defined information and that may be priced, or ordered, or invoiced at any point in any supply chain. This definition covers services and products, from raw materials through to end user products, all of which may have pre-defined characteristics.

The identification and marking of trade items enables the automation of the Point-of-Sale (through Price Look Up (PLU) files), of goods receiving, inventory management, automatic re-ordering, sales analysis, and a wide range of other business applications.

If the item is of variable measure, the respective measure or price information will often be of critical importance to business applications. Attributes relating to trade items (e.g., dates, lot number) are also available as standardised Element Strings.

Each trade item that is different from another in design and/or content is allocated a unique identification number, which remains the same as long as it is traded. The same identification number is given to all trade items sharing key characteristics. Such numbers must be treated in their entirety throughout the supply chain.

The serialised identification of trade items, which enables total connectivity of information and communication systems, is achieved through the use of Application Identifier AI (01) GTIN and AI (21) Serial Number.

Different standard solutions apply depending on the nature of the item and the scope of the user's applications. The following sections determine the identification and symbol marking rules applicable to a particular trade item.

#### 2.1.1.1. Physical or Non-Physical Trade Items

Non-physical trade items are usually called services. Services may be identified with standard numbers for open trade applications or in restricted distribution environments.

#### 2.1.1.2. Open or Restricted Distribution

The main benefit of the GS1 System for trade items is that it provides a unique and unambiguous identification number for every trade item, which is applicable worldwide in open environments. In addition, the system provides for other number series that may be exclusively used for restricted distribution (e.g., national use, company internal use). Restricted distribution identification numbers are available to GS1 Member Organisations' members to help them develop solutions applicable within their territory.

#### 2.1.1.3. Fixed or Variable Measure

Fixed Measure Trade Items are those that are always produced in the same version and composition (e.g., type, size, weight, contents, and design). Like a Fixed Measure Trade Item, a Variable Measure Trade Item is an entity with pre-defined characteristics, such as the nature of the product or its contents. Unlike a Fixed Measure Trade Item, a Variable Measure Trade Item has at least one characteristic that varies whilst other characteristics of the trade item remain the same. The variable characteristic may be weight, dimension, number of items contained, or volume information. The complete identification of a Variable Measure Trade Item consists of both an identification number and information about the variable data.

#### 2.1.1.4. Retail or Non-Retail

Scanning at the Point-of-Sale is a major application of the GS1 System, and trade items that are intended to cross a Point-of-Sale are subject to specific rules.

#### 2.1.1.5. Books and Serial Publications

Published material (newspapers, magazines, and books) requires special consideration due to the following factors:

- A solution for published material should address the requirement to process returns (sorting and counting) to wholesalers and publishers. This implies the reading of a supplementary number that is not required for item identification.
- The international systems, ISSN and ISBN, already handle the numbering of publications and books.

#### 2.1.1.6. Single Item or Grouping of Items

A trade item may be a single, non-breakable unit or a standard and stable grouping of a series of single items. Such groupings of items may be present in a wide variety of physical forms, such as a fibreboard case, a covered or banded pallet, a film wrapped tray, or a crate with bottles. Trade items consisting of a single unit are identified with a Global Trade Item Number (GTIN). Standard groupings of identical or different units, each identified with a GTIN, are identified with a separate GTIN.

#### 2.1.1.7. Very Small Healthcare items

Very small healthcare items are all kinds of very small pharmaceutical and medical products, mainly unit-of-use items and unit dose items, but also very small packages. Specific rules are associated with their use.

#### 2.1.1.8. Direct Part Marked Items

These items are identified separately due their unique marking and reading requirements.

#### 2.1.1.9. Single Trade Items Composed of Several Physical Parts

Because of its physical nature, a trade item may be packed in separate physical parcels. For example, furniture equipment may be composed of several pieces (e.g., a sofa and two armchairs, which cannot be ordered or sold separately). A specific standard solution is available to identify and symbol mark each component of a trade item composed of several physical parts.

### 2.1.2. Fixed Measure Trade Items – Open Supply Chain

Fixed Measure Trade Items are those that are always produced in the same version and composition (e.g., type, size, weight, contents, design). The identification number identifies the item unambiguously. Every trade item that is different from another in any respect is assigned a separate Global Trade Item Number (GTIN). The GS1 Prefixes 000 to 019, 030 to 039, 060 to 099, 100 to 139, 300 to 969, and 977 to 979 are used for all GTINs described in Section 1.4.

#### 2.1.2.1. Retail Consumer Trade Items

A trade item that is intended to cross the Point-of-Sale in a retail outlet must carry a bar code symbol of the EAN/UPC Symbology family. Therefore, these trade items support only GTIN-8, GTIN-12, or GTIN-13s.

Some Point-of-Sale scanning systems may be able to handle symbologies other than the EAN/UPC Symbology. However, in an open environment, it is not possible to predict the type of scanner that will be used. Therefore, items intended for scanning at a Point-of-Sale in a retail outlet must be marked with a bar code symbol of the EAN/UPC Symbology family.

### 2.1.2.1.1. GTIN-12 and GTIN-13 Carried by an EAN/UPC Bar Code Symbol

#### Application Description

Figure 2.1.2.1.1 - 1

GTIN-12 / GTIN-13 Data Structure													
GS1 Company Prefix						Item Reference						Check Digit	
(GTIN-13)	N <sub>1</sub>	N <sub>2</sub>	N <sub>3</sub>	N <sub>4</sub>	N <sub>5</sub>	N <sub>6</sub>	N <sub>7</sub>	N <sub>8</sub>	N <sub>9</sub>	N <sub>10</sub>	N <sub>11</sub>	N <sub>12</sub>	N <sub>13</sub>
(GTIN-12)	0	N <sub>1</sub>	N <sub>2</sub>	N <sub>3</sub>	N <sub>4</sub>	N <sub>5</sub>	N <sub>6</sub>	N <sub>7</sub>	N <sub>8</sub>	N <sub>9</sub>	N <sub>10</sub>	N <sub>11</sub>	N <sub>12</sub>

The GS1 Company Prefix is allocated by a GS1 Member Organisation to a system user. It makes the ID number unique worldwide but does not identify the origin of the item. GS1 Company Prefixes starting with GS1 Prefixes 000 to 019, 030 to 039, 060 to 099, 100 to 139, 300 to 969, or 977 to 979 in the first three digits are used in this Element String.

The Item Reference is assigned by the system user, who must observe the rules in Section 4.

The Check Digit is explained in Section 7.10. Its verification, carried out automatically by the bar code reader, ensures that the number is correctly composed.

#### GS1 Key

##### Definition

- The GTIN-12 is the 12-digit GS1 Identification Key composed of a U.P.C. Company Prefix, Item Reference, and Check Digit used to identify trade items.
- The GTIN-13 is the 13-digit GS1 Identification Key composed of a GS1 Company Prefix, Item Reference, and Check Digit used to identify trade items.

##### Rules

All the GTIN Allocation Rules described in Section 4.

##### Attributes

##### Required

Not Applicable

##### Optional

For all the Application Identifiers (AI) that can be used with a GTIN, see Section 3.

##### Rules

Not Applicable

## Data Carrier Specification

### **Carrier Choices**

The data carriers for this Element String are:

- UPC-A Bar Code Symbol (carrying a GTIN-12)
- EAN-13 Bar Code Symbol (carrying a GTIN-13)

The system recognises this Element String by the symbology identifier **JE0** and the GS1 Prefixes starting with 000 to 019, 030 to 039, 060 to 099, 100 to 139, 300 to 969, or 977 to 979.

The data transmitted from the bar code reader means that one Fixed Measure Trade Item with a GTIN-13 has been captured.

### **Symbol X-Dimensions, Minimum Symbol Height, and Minimum Symbol Quality**

See Section 5.5, Figure 5.5.2.7 - 2, GS1 System Symbol Specification Table 1, and Figure 5.5.2.7 - 4, GS1 System Symbol Specification Table 3.

### **Symbol Placement**

All the Symbol Placement Guidelines are defined in Section 6.

### **Unique Application Processing Requirements**

For a description of processing requirements, see Section 7.

## 2.1.2.1.2. GTIN-12 Carried by a UPC-E Bar Code Symbol

### **Application Description**

Only U.P.C. Company Prefixes beginning with zero can be used to construct UPC-E Bar Code Symbols. Distribution of a U.P.C. Company Prefix in this range is restricted to proven need only (e.g., for items whose packaging does not include enough available space to permit the use of any other bar code symbol). Companies with these prefixes are encouraged to manage their finite resource carefully.

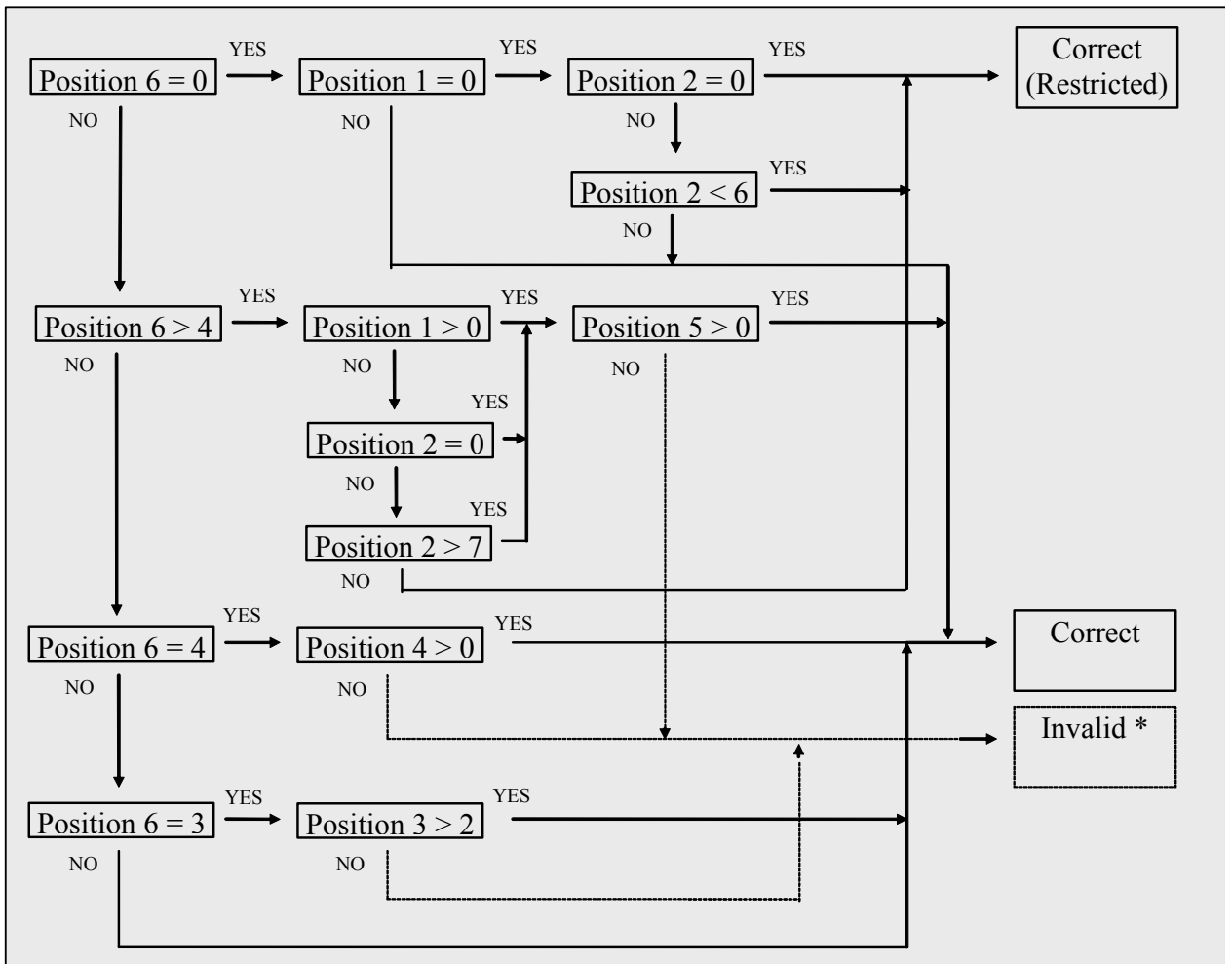
Some GTIN-12s beginning with the U.P.C. Prefix 0 may be represented in a small symbol called the UPC-E Bar Code Symbol. The GTIN-12 is condensed into a bar code symbol consisting of six symbol character positions. For application processing, the GTIN-12 must be transformed into its full length by the bar code reader software or by the application software. There is no six-digit UPC-E Bar Code Symbol.

See Figure 7.11 - 1 and Figure 7.11 - 2 for UPC-E Bar Code Symbol options.

It is possible to create false UPC-E Bar Code Symbols if the encodation rules are not properly observed. Whether the digits represented in a UPC-E Bar Code Symbol can be expanded correctly to a GTIN-12 may be verified by the following tests:

**Test 1:** Verify the digits encoded in Positions 1 to 6 of the UPC-E Bar Code Symbol according to the diagram in Figure 2.1.2.1.2 - 1.

Figure 2.1.2.1.2 - 1



**Note:** These UPC-E Bar Code Symbols were valid in previous specifications. Provision for accepting them must be made during decoding only.

**Test 2:** Expand the digits encoded in the UPC-E Bar Code Symbol to the first 11 digits of the full length GTIN-12, calculate the Check Digit, and compare it with the Check Digit decoded from the UPC-E Bar Code Symbol. If they do not match, it signifies an invalid symbol.

**GS1 Key**

**Definition**

The 12-digit GS1 Identification Key composed of a U.P.C. Company Prefix, Item Reference, and Check Digit used to identify trade items.

**Rules**

All the GTIN Allocation Rules described in Section 4.

**Attributes**

**Required**

Not Applicable

**Optional**

Not Applicable

**Rules**

Not Applicable

**Data Carrier Specification**

**Carrier Choices**

The UPC-E Bar Code Symbol is a bar code symbol of the EAN/UPC Symbology representing a GTIN-12 in six explicitly encoded digits using zero-suppression techniques.

**Symbol X-Dimensions, Minimum Symbol Height, and Minimum Symbol Quality**

See Section 5.5, Figure 5.5.2.7 - 2, GS1 System Symbol Specification Table 1.

**Symbol Placement**

All the Symbol Placement Guidelines defined in Section 6.

**Unique Application Processing Requirements**

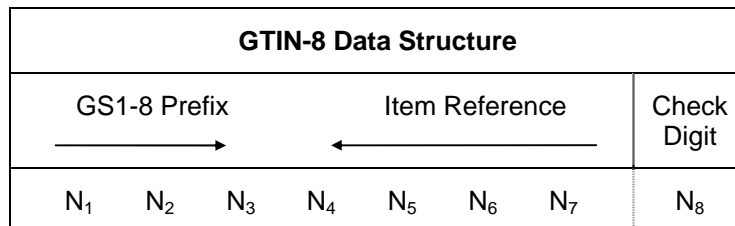
For a description of processing requirements, see Section 7.

**2.1.2.1.3. GTIN-8 Carried by an EAN-8 Bar Code Symbol**

**Application Description**

The GTIN-8 is available for items whose packaging does not include enough available space to permit the use an EAN-13 or UPC-A Symbol. GTIN-8s are individually assigned by GS1 Member Organisations on request. Figure 2.1.2.1.3 - 1 shows the data structure of a GTIN-8.

**Figure 2.1.2.1.3 - 1**



The GS1-8 Prefix is a one-, two-, or three-digit index number, administered by the GS1 Global Office. It does not identify the origin of the item. GS1 Prefixes 100 to 139 and 300 to 969 in positions N1 to N3 are used in this Element String.

The Item Reference is assigned by the GS1 Member Organisation. The GS1 Member Organisations provide procedures for obtaining GTIN-8s.

The Check Digit is explained in Section 7.10. Its verification, carried out automatically by the bar code reader, ensures that the number is correctly composed.

**GS1 Key**

**Definition**

The 8-digit GS1 Identification Key composed of a GS1-8 Prefix, Item Reference, and Check Digit used to identify trade items.

## Rules

In addition to the GTIN Allocation Rules described in Section 4, the following guidelines should be observed:

Before deciding to use a GTIN-8 as opposed to a GTIN-13 or GTIN-12, companies, working jointly with their printer, should consider options such as:

- Whether the bar code can be reduced in size (e.g., printed at a lower X-dimension, taking into account the minimum bar code symbol print quality requirements (see Section 5.5)).
- Whether the label or artwork can reasonably be changed to enable the printer's recommended size of a EAN-13 or UPC-A Bar Code Symbol to be included (e.g., redesigning the label and increasing the label size, especially when the existing label is small in comparison with the pack area, or using an additional label). The label includes the total printed design surface whether or not it is separately affixed.
- Whether a truncated bar code symbol can be used. A truncated bar code symbol (normal length, but reduced in height) may only be used if there is absolutely no possibility of printing a full size bar code symbol. Truncation removes the omni-directional scanning capability. A bar code symbol with excessive truncation will not be of any practical use. Users considering this option should consult their customers to see if an acceptable compromise can be reached.

Pack size constraints allow several possible options:

- The use of a GTIN-8 is authorised when the EAN-13 or UPC-A Bar Code Symbol in the size required as a result of print quality studies exceeds either 25 percent of the printed label area or 12.5 percent of the total printable area.
- The use of a GTIN-8 is authorised when either the largest side of the printed label is less than 40 centimetres<sup>2</sup> or the total printable area is less than 80 centimetres<sup>2</sup>.
- The use of a GTIN-8 is authorised on cylindrical products with a diameter less than 3 centimetres.

## Attributes

### Required

Not Applicable

### Optional

Not Applicable

## Rules

Not Applicable

## Data Carrier Specification

### Carrier Choices

The data carrier for a GTIN-8 is the EAN-8 Bar Code Symbol.

The system recognises this Element String by the symbology identifier **JE4** and by N1 not being 0 or 2. The data transmitted from the bar code reader means that one Fixed Measure Trade Item with a GTIN-8 has been captured.

### **Symbol X-Dimensions, Minimum Symbol Height, and Minimum Symbol Quality**

See Section 5.5, Figure 5.5.2.7 - 2, GS1 System Symbol Specification Table 1.

### **Symbol Placement**

All the Symbol Placement Guidelines defined in Section 6.

### **Unique Application Processing Requirements**

For a description of processing requirements, see Section 7.

## **2.1.2.1.4. Hardcover Books and Paperbacks: ISBN, GTIN-13, and GTIN-12**

### **Application Description**

When identifying books and paperbacks a company may identify them in the same manner as any other retail trade item (see Section [2.1.2.1](#)). However, the recommended option is to use the International Standard Book Number (ISBN numbering system). The GS1 Prefixes 978 and 979 have been allocated to ISBN (<http://www.isbn-international.org/>), who allocate numbers from this 'Bookland' prefix.



**Note:** ISBNs shall not be allocated to non-book products even if the products are related to a book (e.g., teddy bears, coffee mugs, T-shirts, etc. related to a book launch). Such non-book products shall be identified and bar coded in the same manner as any other retail trade item (see Section [2.1.2.1](#)). A standard grouping of identical book items would normally be identified according to Section [2.1.2.3.2](#). However, an ISBN may also be used to create a 14-digit GTIN with an Indicator to identify a grouping of identical book items (refer to Section [2.1.2.3.2](#)) provided that the publisher that issues the 14-digit GTIN is a member of a GS1 organisation or is authorised to act through an agreement between its local GS1 organisation and the local organisation representing publishers.

### **GS1 Key**

#### **Definition**

The Global Trade Item Number (GTIN) is the GS1 Identification Key used to identify trade items. The key is comprised of a GS1 or U.P.C. Company Prefix followed by an Item Reference Number and a Check Digit.

#### **Rules**

All the GTIN Allocation Rules described in Section 4, In addition, the main bar code symbols on books and paperback must not be reduced in height.

### **Attributes**

#### **Required**

Not Applicable

#### **Optional**

Some publishers may wish to communicate additional information in a bar code symbol in order to meet their internal requirements. For example, publishers may wish to include an edition variant (e.g., unchanged reprint, price increase), which is not distinguished by the ISBN, GTIN-13, or GTIN-12. The GS1 System provides an additional two- or five-digit symbol, called an Add-On Symbol that can be included on the item just to the right of the main bar code symbol.

A two-digit or five-digit serial number provides more information about a particular publication of the printed item, but it is not required for the identification of the title itself.

This figure shows the format of a two-digit Add-On:

**Figure 2.1.2.1.4 - 1**

Supplementary Information	
N <sub>1</sub>	N <sub>2</sub>

The supplementary information consists of numeric data of any structure and meaning. It is the publisher's responsibility to define the numbering scheme.

The data carrier for this Element String is the two-digit Add-On Symbol.

The system recognises this Element String by the Symbology Identifier **JE1**. The two-digit Add-On Symbol must be jointly used with a UPC-A, UPC-E or EAN-13 Bar Code Symbol. It is never scanned alone, and the data from both bar code symbols can be used together for processing.

This figure shows the format of a five-digit Add-On:

**Figure 2.1.2.1.4 - 2**

Supplementary Information				
N <sub>1</sub>	N <sub>2</sub>	N <sub>3</sub>	N <sub>4</sub>	N <sub>5</sub>

The supplementary information consists of numeric data of any structure and meaning. It is the publisher's responsibility to define the numbering scheme.

The data carrier for this Element String is the two-digit or five-digit Add-On Symbol.

The system recognises this Element String by the Symbology Identifier **JE2**. The five-digit Add-On Symbol must be jointly used with a UPC-A, UPC-E or EAN-13 Bar Code Symbol. It is never scanned alone, and the data from both bar code symbols can be used together for processing.

**Rules**

Add-On Symbols involve the following constraints:

- They should not contain information that should rightly be looked up using the item's GTIN-13 (or GTIN-12).
- The reading of the Add-On Symbol by the retailer's Point-of-Sale system is optional.
- The use of the Add-On Symbol is the responsibility of each publisher.

**Data Carrier Specification**

**Carrier Choices**

Books and paperbacks should be marked with an EAN-13, UPC-A, or UPC-E Bar Code Symbol that complies with the print quality specifications applicable to all GS1 System bar code symbols. The EAN/UPC 2-digit or 5-digit Add-on symbols are options used with the above EAN/UPC symbols.

**Symbol X-Dimensions, Minimum Symbol Height, and Minimum Symbol Quality**

See Section 5.5, Figure 5.5.2.7 - 2, GS1 System Symbol Specification Table 1.

**Symbol Placement**

All the Symbol Placement Guidelines defined in Section 6.4.11. In addition, the main bar code symbols on books and paperbacks must appear on the outside cover of the book (to facilitate payment) and inside the cover for books that are subject to return.

**Unique Application Processing Requirements**

For description of processing requirements, see Section 7.

**2.1.2.1.5. Serial Publications: ISSN, GTIN-13, and GTIN-12**

**Application Description**

When identifying serial publications, companies should first attempt to identify them in the same manner as any other trade item: using the GTIN-13 or GTIN-12 Data Structure.

The second option involves using a special GS1 Company Prefix (assigned by a GS1 Member Organisation within its territory), the publication number, and the price of the publication (provided that the national legislation allows this). With this option, the price is placed in clearly defined positions and is directly usable in the country of publication. However, as soon as the item leaves the country, the price has no direct significance, and the GTIN must be interpreted in a general way without being broken down internally.

The third option is to make use of the ISSN numbering system. The GS1 Prefix 977 is used for encoding the ISSN assigned to a particular item without its Check Digit.

**Figure 2.1.2.1.5 - 1**

GS1 Prefix	ISSN (without its Check Digit)	Variant	Check Digit
9 7 7	N <sub>4</sub> N <sub>5</sub> N <sub>6</sub> N <sub>7</sub> N <sub>8</sub> N <sub>9</sub> N <sub>10</sub>	N <sub>11</sub> N <sub>12</sub>	N <sub>13</sub>

The variant digits N11 and N12 may be used to express variants of the same title for issues with a different price or to identify different issues of a daily within one week. Normal title takes value 00.

**GS1 Key**

**Definition**

The Global Trade Item Number (GTIN) is the GS1 Identification Key used to identify trade items. The key is comprised of a GS1 or U.P.C. Company Prefix followed by an Item Reference Number and a Check Digit.

**Rules**

All the GTIN Allocation Rules described in Section 4; in addition, the main bar code symbols on books and paperback must not be reduced in height.

**Attributes**

**Required**

Not Applicable

**Optional**

Some publishers may wish to communicate additional information in a bar code symbol in order to meet their internal requirements.

A two-digit or five-digit serial number provides more information about a particular publication of the printed item, but it is not required for the identification of the title itself.

This figure shows the format of a two-digit Add-On:

**Figure 2.1.2.1.5 - 2**

Serial Number Publications	
N <sub>1</sub>	N <sub>2</sub>

GS1 Global Office recommends the use of the following number assignment:

- Dailies (or more generally publications with several issues a week): The publications of each day of the week are considered separate trade items that must be identified with a separate identification number represented in an Add-On Symbol. The two-digit serial number should only be used to represent the applicable week, which, together with the GTIN-13 or GTIN-12, establishes the day within the year.
- Weeklies: Number of the week (01 – 53)
- Bi-weeklies: Number of the first week of the respective period (01 – 53)
- Monthlies: Number of the month (01 – 12)
- Bi-monthlies: Number of the first month of the respective period (01 – 12)
- Quarterlies: Number of the first month of the respective period (01 – 12)
- Seasonal period: First digit = last digit of the year; second digit = 1 spring, 2 summer, 3 autumn, 4 winter
- Bi-annual period: First digit = last digit of the year; second digit = number of the first season of the respective period
- Annuals: First digit = last digit of the year; second digit = 5
- Special intervals: Consecutively numbered from 01 to 99

The serial number is carried by a two-digit Add-On Symbol that is placed to the right of the symbol and parallel to it. The Add-On Symbol must comply with the print quality specifications applicable to all GS1 System bar code symbols. For example, the X-dimension applied to the main bar code symbol must also be applied to the Add-On Symbol.

Serial publications can also use a five-digit serial number carried by a five-digit Add-On Symbol. The reading of the Add-On Symbol at a Point-of-Sale is optional. The Add-On Symbol must not be used to encode information that should be contained within the Global Trade Item Number (GTIN). The Add-On Symbol provides additional information about a particular publication of a printed item, and it is the publisher's responsibility to define the numbering scheme.

This figure shows the format of a five-digit Add-On:

**Figure 2.1.2.1.5 - 3**

Supplementary Information				
N <sub>1</sub>	N <sub>2</sub>	N <sub>3</sub>	N <sub>4</sub>	N <sub>5</sub>

Information that can be encoded in the five-digit Add-On Symbol includes the actual date of issue, in order to differentiate between successive issues.

The five-digit Add-On Symbol is placed to the right of the main bar code symbol and parallel to it. The Add-On Symbol must comply with the print quality specifications applicable to all GS1 System bar code symbols. For example, the X-dimension applied to the main symbol also must be applied to the Add-On Symbol.

**Rules**

When using a five-digit Add-On Symbol, a two-digit Add-On Symbol cannot also be used.

**Data Carrier Specification****Carrier Choices**

Serial Publications should be marked with an EAN-13, UPC-A, or UPC-E Bar Code Symbol that complies with the print quality specifications applicable to all GS1 System bar code symbols. The EAN/UPC 2-digit or 5-digit Add-on symbols are options used with the above EAN/UPC symbols.

**Symbol X-Dimensions, Minimum Symbol Height, and Minimum Symbol Quality**

See Section 5.5, Figure 5.5.2.7 – 2, GS1 System Symbol Specification Table 1.

**Symbol Placement**

All the Symbol Placement Guidelines defined in Section 6.4.11.

**Unique Application Processing Requirements**

For a description of processing requirements, see Section 7.

**2.1.2.1.6. Trade Item Groupings****Application Description**

Two kinds of groupings are defined:

**■ Pre-defined assortments**

A standard trade item grouping that comprises a fixed configuration of two or more different retail consumer items, each identified with a Global Trade Item Number (GTIN). Any change in the configuration of the assortment is considered a new trade item.

**■ Dynamic assortments**

A standard trade item grouping that comprises a fixed count of a changing assortment of two or more different retail consumer trade items, each identified with a unique GTIN. All of the retail consumer trade items and their GTINs will have been communicated to the retailer before trading takes place. The retailer has accepted that the supplier may change the assortment without any prior notice.

**GS1 Key****Definition**

The Global Trade Item Number (GTIN) is the GS1 Identification Key used to identify trade items. The key is comprised of a GS1 or U.P.C. Company Prefix followed by an Item Reference Number and a Check Digit.

**Rules**

All the GTIN Allocation Rules described in Section 4.

**Attributes****Required**

Not Applicable

**Optional**

All the Application Identifiers (AI) that can be used with a GTIN (see Section 3).

**Rules**

Not Applicable

**Data Carrier Specification**

**Carrier Choices**

A standard trade item grouping that is intended to cross the Point-of-Sale in a retail outlet must carry a bar code symbol of the EAN/UPC Symbology family. Therefore, these trade items support GTIN-12s or GTIN-13s. Allowable symbols are EAN-13 and UPC-A.

**Symbol X-Dimensions, Minimum Symbol Height, and Minimum Symbol Quality**

See Section 5.5, Figure 5.5.2.7 – 2, GS1 System Symbol Specification Table 1.

**Symbol Placement**

All the Symbol Placement Guidelines defined in Section 6.

**Unique Application Processing Requirements**

For a description of processing requirements, see Section 7.

**2.1.2.2. Trade Items Intended for General Distribution and POS**

Trade items intended for general distribution and Point-of-Sale scanning must carry a bar code symbol of the EAN/UPC Symbology family. Therefore, these trade items support GTIN-12s or GTIN-13s (see Section [2.1.2.1.1](#)).

**2.1.2.3. Trade Items Intended for General Distribution Scanning Only**

Every trade item that is different from another in any respect is assigned a unique Global Trade Item Number (GTIN). This includes groupings of trade items that are also trade items.

For example, each of the packaging types in Figure 2.1.2.3 - 1, if traded, is assigned a separate GTIN.

Figure 2.1.2.3 - 1

Trade Item	GTIN Numbering Options			
	GTIN-8	GTIN-12	GTIN-13	GTIN-14
Single Product A	X	X	X	
50 x Product A (standard case)		X	X	X
50 x Product A (display case)		X	X	X
100 x Product A (standard case)		X	X	X
Single Product B	X	X	X	
50 x Product A 50 x Product B		X	X	

### 2.1.2.3.1. Identification of a Trade Item that is a Single Product

#### Application Description

The manufacturer or supplier has the option of either assigning a unique GTIN-8, GTIN-12 or GTIN-13 to a trade item that is a single product as shown in Figure 2.1.2.3 - 1.

GTINs for restricted distribution must not be used in this Element String.

#### GS1 Key

##### Definition

- The GTIN-8 is the 8-digit GS1 Identification key composed of a GS1-8 Prefix, Item Reference, and Check Digit used to identify trade items.
- The GTIN-12 is the 12-digit GS1 Identification Key composed of a U.P.C. Company Prefix, Item Reference, and Check Digit used to identify trade items.
- The GTIN-13 is the 13-digit GS1 Identification Key composed of a GS1 Company Prefix, Item Reference, and Check Digit used to identify trade items.

##### Rules

In addition to the GTIN Allocation Rules described in Section 4, the following guidelines should be observed: GTIN-8 can only be used when all other pack size constraints are met.

Before deciding to use a GTIN-8 as opposed to a GTIN-13 or GTIN-12, companies, working jointly with their printer, should consider options such as:

- Whether the bar code can be reduced in size (e.g., printed at a lower X-dimension, taking into account the minimum bar code symbol print quality requirements (see Section 5.5)).
- Whether the label or artwork can reasonably be changed to enable the printer's recommended size of a EAN-13 or UPC-A Bar Code Symbol to be included (e.g., redesigning the label and increasing the label size, especially when the existing label is small in comparison with the pack area, or using an additional label). The label includes the total printed design surface whether or not it is separately affixed.
- Whether a truncated bar code symbol can be used. A truncated bar code symbol (normal length, but reduced in height) may only be used if there is absolutely no possibility of printing a full size bar code symbol. Truncation removes the omni-directional scanning capability. A bar code symbol with excessive truncation will not be of any practical use. Users considering this option should consult their customers to see if an acceptable compromise can be reached.

Pack size constraints allow several possible options:

- The use of a GTIN-8 is authorised when the EAN-13 or UPC-A Bar Code Symbol in the size required as a result of print quality studies exceeds either 25 percent of the printed label area or 12.5 percent of the total printable area.
- The use of a GTIN-8 is authorised when either the largest side of the printed label is less than 40 centimetres<sup>2</sup> or the total printable area is less than 80 centimetres<sup>2</sup>.
- The use of a GTIN-8 is authorised on cylindrical products with a diameter less than 3 centimetres.

#### Attributes

##### Required

Not Applicable

**Optional**

All the Application Identifiers (AI) that can be used with a GTIN (see Section 3).

**Rules**

Not Applicable

**Data Carrier Specification**

**Carrier Choices**

Symbols from the EAN/UPC Symbology family (UPC-A, UPC-E, may be used to encode the GTIN-12, EAN-13 to encode the GTIN-13 and, if the size requirements are met, EAN-8 to encode the GTIN-8) of the trade item grouping.

ITF-14 Symbols may be used where printing conditions require the application of a less demanding symbology. ITF-14 Symbols can encode the GTIN-12, or GTIN-13 of the item.

The GS1-128 Symbology with Application Identifier (01) may be used to encode a GTIN-12, or GTIN-13 that identifies the trade item if the printing conditions allow. The choice of this symbology is particularly relevant if there is a need to encode attribute information in addition to the identification number.

**Symbol X-Dimensions, Minimum Symbol Height, and Minimum Symbol Quality**

See Section 5.5, Figure 5.5.2.7 – 3, GS1 System Symbol Specification Table 2.

**Symbol Placement**

All the Symbol Placement Guidelines defined in Section 6.

**Unique Application Processing Requirements**

For a description of processing requirements, see Section 7.

**2.1.2.3.2. Identification of Uniform Groupings of Trade Items**

**Application Description**

A uniform grouping of trade items is a standard and stable grouping of identical trade items. The manufacturer or supplier has the option of either assigning a unique GTIN-13 or GTIN-12 to each grouping or assigning a unique GTIN-14. These 14-digit GTINs incorporate the GTIN of the trade item (less its Check Digit) contained in each grouping. The Check Digit for each GTIN-14 is then recalculated.

The Indicators have no meaning. The digits do not have to be used in sequential order, and some may not be used at all. The GTIN-14 structure for standard trade item groupings creates extra numbering capacity. Indicators can be re-used.

**Figure 2.1.2.3.2 – 1**

Format of the Element String														
Global Trade Item Number (GTIN)														
Indicator	GTIN of Contained Trade Items (Without Check Digit)												Check Digit	
GTIN-8 based	N <sub>1</sub>	0	0	0	0	0	N <sub>7</sub>	N <sub>8</sub>	N <sub>9</sub>	N <sub>10</sub>	N <sub>11</sub>	N <sub>12</sub>	N <sub>13</sub>	N <sub>14</sub>
GTIN-12 based	N <sub>1</sub>	0	N <sub>3</sub>	N <sub>4</sub>	N <sub>5</sub>	N <sub>6</sub>	N <sub>7</sub>	N <sub>8</sub>	N <sub>9</sub>	N <sub>10</sub>	N <sub>11</sub>	N <sub>12</sub>	N <sub>13</sub>	N <sub>14</sub>
GTIN-13 based	N <sub>1</sub>	N <sub>2</sub>	N <sub>3</sub>	N <sub>4</sub>	N <sub>5</sub>	N <sub>6</sub>	N <sub>7</sub>	N <sub>8</sub>	N <sub>9</sub>	N <sub>10</sub>	N <sub>11</sub>	N <sub>12</sub>	N <sub>13</sub>	N <sub>14</sub>

The Indicator is a digit with a value of 1 to 8. It is assigned as required by the company that constructs the identification number. It can provide up to eight separate GTIN-14s to identify groupings of trade items.

The 8-, 12-, or a 13-digit GTIN of the trade items contained must always be the one of the relevant levels of packaging contained, usually the lowest level. GTINs for restricted distribution must not be used in this Element String.

The Check Digit is explained in Section 7.10. Its verification, usually carried out automatically by the bar code reader, ensures that the number is correctly composed.

**Figure 2.1.2.3.2 - 2**  
**Different Uniform Groupings of the Same Trade Item**

Indicator	GTIN of Trade Item Contained in the Grouping, Less Its Check Digit	New Check Digit	Description	Quantity
	061414112345	2	Trade item	Single
1	061414112345	9	Standard trade item grouping	A grouping
...	...	...	...	...
8	061414112345	8	Standard trade item grouping	Another grouping

Indicators 1 to 8 may be used to create new GTIN-14s. When these eight Indicators have been used, further groupings must be identified with either a GTIN-13 or GTIN-12. (Indicator digit 9 is reserved for Variable Measure Trade Items). (See Section [2.1.6](#))

**GS1 Key**

**Definition**

- The GTIN-8 is the 8-digit GS1 Identification key composed of a GS1-8 Prefix, Item Reference, and Check Digit used to identify trade items
- The GTIN-12 is the 12-digit GS1 Identification Key composed of a U.P.C. Company Prefix, Item Reference, and Check Digit used to identify trade items.
- The GTIN-13 is the 13-digit GS1 Identification Key composed of a GS1 Company Prefix, Item Reference, and Check Digit used to identify trade items.
- The GTIN-14 is the 14-digit GS1 Identification Key composed of an Indicator digit (1-9), GS1 Company Prefix, Item Reference, and Check Digit used to identify trade items.

**Rules**

All the GTIN Allocation Rules described in Section 4,

**Attributes**

**Required**

Not Applicable

**Optional**

All the Application Identifiers (AI) that can be used with a GTIN (see Section 3).

**Rules**

Not Applicable

## Data Carrier Specification

### Carrier Choices

Symbols from the EAN/UPC Symbology family (UPC-A, UPC-E, and EAN-13) may be used to encode the GTIN-12 or GTIN-13 of the trade item grouping. If used, the GTIN-8 is encoded in an EAN-8 Bar Code. GTIN-8 can only be used when all other pack size constraints are met, see Section [2.1.2.1.3](#). The system recognises this Element String by the symbology identifier **JE0**.

ITF-14 Symbols may be used on groupings of trade items where printing conditions require the application of a less demanding symbology. ITF-14 Symbols can encode the GTIN-12, GTIN-13, or GTIN-14 of the item. The system recognises this Element String by the symbology identifier **J11** and the number of digits decoded (14).

The GS1-128 Symbology with Application Identifier (01) may be used to encode a GTIN-12, GTIN-13, or GTIN-14 that identifies the trade item if the printing conditions allow. The choice of this symbology is particularly relevant if there is a need to encode attribute information in addition to the identification number. The system recognises this Element String by the symbology identifier **JC1** and the Application Identifier.

### *Symbol X-Dimensions, Minimum Symbol Height, and Minimum Symbol Quality*

See Section 5.5, Figure 5.5.2.7 - 3, GS1 System Symbol Specification Table 2.

### *Symbol Placement*

All the Symbol Placement Guidelines defined in Section 6.

### Unique Application Processing Requirements

For a description of processing requirements, see Section 7.

## 2.1.2.3.3. Identification of Mixed Groupings of Trade Items

### Application Description

A mixed grouping of trade items is a standard and stable grouping of two or more different trade items.

For example:

- Product C is a mixed grouping of Product A (GTIN 'A') and Product B (GTIN 'B'), and is identified with either a GTIN-12 or GTIN-13, GTIN 'C.'
- GTIN 'C' could then be used to construct a GTIN-14 for a standard trade item grouping comprised of Product C.

As shown in Figure 2.1.2.3.3 - 1, the GTIN-12s 614141234561 and 614141345670 identify the two trade items in the assortment identified by the GTIN 614141456789.

Figure 2.1.2.3.3 - 1

Indicator	GTIN of Trade Item Less Its Check Digit	Check Digit	Description	Quantity
	061414123456 061414134567	1 0	Retail consumer trade item (Product A) Retail consumer trade item (Product B)	Single Single
	061414145678	9	Retail consumer trade item (Product C)	Assortment
1	061414145678	6	Standard trade item grouping	A grouping of the assortment
...	...	...	...	...
8	061414145678	5	Standard trade item grouping	Another grouping of the assortment

The Indicators 1 to 8 may be used to create new GTIN-14s. When these eight Indicators have been used, further groupings must be identified with either a GTIN-13 or GTIN-12. (Indicator digit 9 is reserved for Variable Measure Trade Items). (See Section [2.1.6](#))

**GS1 Key**

**Definition**

- The GTIN-12 is the 12-digit GS1 Identification Key composed of a U.P.C. Company Prefix, Item Reference, and Check Digit used to identify trade items.
- The GTIN-13 is the 13-digit GS1 Identification Key composed of a GS1 Company Prefix, Item Reference, and Check Digit used to identify trade items.
- The GTIN-14 is the 14-digit GS1 Identification Key composed of an Indicator digit (1-9), GS1 Company Prefix, Item Reference, and Check Digit used to identify trade items

**Rules**

All the GTIN Allocation Rules described in Section 4; in addition, the GTIN-14 is valid for mixed groupings only when the trade item contained is an assortment of two or more different trade items.

**Attributes**

**Required**

Not Applicable

**Optional**

See Section 3 for all the Application Identifiers (AIs) that can be used with a GTIN. Since the GTIN identifies a grouping of items, the optional attributes apply to the grouping as well.

Not Applicable

**Data Carrier Specification**

**Carrier Choices**

Symbols from the EAN/UPC Symbology family (UPC-A, UPC-E, and EAN-13) may be used to encode the GTIN-12 or GTIN-13 of the trade item grouping. The system recognises this Element String by the symbology identifier **JE0**.

ITF-14 Symbols may be used on groupings of trade items where printing conditions require the application of a less demanding symbology. ITF-14 Symbols can encode the GTIN-12, GTIN-13, or

GTIN-14 of the item. The system recognises this Element String by the symbology identifier **J11** and the number of digits decoded (14).

The GS1-128 Symbology with Application Identifier (01) may be used to encode a GTIN-12, GTIN-13, or GTIN-14 that identifies the trade item if the printing conditions allow. The choice of this symbology is particularly relevant if there is a need to encode attribute information in addition to the identification number. The system recognises this Element String by the symbology identifier **JC1** and the Application Identifier

***Symbol X-Dimensions, Minimum Symbol Height, and Minimum Symbol Quality***

See Section 5.5, Figure 5.5.2.7 - 3, GS1 System Symbol Specification Table 2.

***Symbol Placement***

All the Symbol Placement Guidelines defined in Section 6.

**Unique Application Processing Requirements**

For a description of processing requirements, see Section 7.

### 2.1.3. Fixed Measure – Very Small Healthcare Items

**Application Description**

Very small healthcare items are all kinds of very small pharmaceutical and medical products, mainly unit-of-use items and unit dose items, but also very small packages.

**GS1 Key**

***Definition***

- The GTIN-8 is the 8-digit GS1 Identification Key composed of a GS1-8 Prefix, Item Reference, and Check Digit used to identify trade items.
- The GTIN-12 is the 12-digit GS1 Identification Key composed of a U.P.C. Company Prefix, Item Reference, and Check Digit used to identify trade items.
- The GTIN-13 is the 13-digit GS1 Identification Key composed of a GS1 Company Prefix, Item Reference, and Check Digit used to identify trade items.
- The GTIN-14 is the 14-digit GS1 Identification Key composed of an Indicator digit (1-9), GS1 Company Prefix, Item Reference, and Check Digit used to identify trade items.


***Rules***

All the GTIN Allocation Rules described in Section 4.

**Attributes**


***Required***

See in Section 3.2 the List of all GS1 Application Identifier, Identification of a Fixed Measure Trade Item (GTIN): AI (01).

-  **Note:** The GS1 DataBar Limited (formerly RSS Limited) cannot encode GTIN-14 starting with indicator position values 2 to 9

***Optional***

An item may also contain a symbol encoding secondary attribute data. It is recommended to adopt the Expiration Date (see Section 3, AI (17)) and the Batch or Lot Number (see Section 3, AI (10)).

-  **Note:** Multiple AI data elements may be concatenated in a single 2D Composite Component message or in a GS1 DataMatrix Symbol. If a GS1 DataMatrix Symbol is used, the optional data must follow the GTIN information.

### **Rules**

All the GTIN Allocation Rules described in Section 4; in addition, expiry date and lot number are normally legally expressed minimally in Human Readable Interpretation on the label or package. Automatic handling (scanning and electronic delivery) of this data facilitates many maintenance and documentation duties.

### **Data Carrier Specification**

#### **Carrier Choices**

Symbols from the EAN/UPC Symbology family (UPC-A, UPC-E, may be used to encode the GTIN-12, EAN-13 to encode the GTIN-13 and, if the size requirements are met, EAN-8 to encode the GTIN-8) may be used for the very small healthcare items.

In addition, GS1-128 Symbology, GS1 DataBar Symbology (formerly RSS), and GS1 DataMatrix Symbology may be used.

#### **Symbol X-Dimensions, Minimum Symbol Height, and Minimum Symbol Quality**

See Section 5.5, Figure 5.5.2.7 - 5, GS1 System Symbol Specification Table 4, Figure 5.5.2.7 - 7, GS1 System Symbol Specification Table 6 and Figure 5.5.2.7 - 8, GS1 System Symbol Specification Table 7.

#### **Symbol Placement**

All the Symbol Placement Guidelines defined in Section 6.

### **Unique Application Processing Requirements**

For a description of processing requirements, or Linear BarCodes see Section 7.

## **2.1.4. Fixed Measure – Trade Items Packed in Several Physical Units NOT Scanned at POS**

### **Application Description**

The trade item that does not cross a Point-of-Sale, due to its nature, is packed in several physical units. Each individual component consists of the Global Trade Item Number (GTIN) of the trade item, the sequence number of the particular component, and the total number of components of the trade item. If an attribute appears on more than one component, its value must be the same. See Section 3, Identification of the Components of a Trade Item: AI (8006).

### **GS1 Key**

#### **Definition**

The Global Trade Item Number (GTIN) is the GS1 Identification Key used to identify trade items. The key is comprised of a GS1 or U.P.C. Company Prefix followed by an Item Reference Number and a Check Digit.

#### **Rules**

All the GTIN Allocation Rules described in Section 4.

## Attributes

### **Required**

See in Section 3.2 the List for all GS1 Application Identifier, Identification of the Components of a Trade Item: AI (8006).

### **Optional**

Not Applicable

### **Rules**

The use of the Element String AI (8006) to identify a trade item excludes the application of the Element String AI (01) on the same unit.

This solution is not applicable for trade items crossing Point-of-Sale using slot scanners.

## Data Carrier Specification

### **Carrier Choices**

Each individual component using the Application Identifier AI (8006) is carried by the GS1-128 Bar Code Symbol.

### **Symbol X-Dimensions, Minimum Symbol Height, and Minimum Symbol Quality**

See Section 5.5, Figure 5.5.2.7 – 3, GS1 System Symbol Specification Table 2.

### **Symbol Placement**

All the Symbol Placement Guidelines defined in Section 6.

## Unique Application Processing Requirements

For a description of processing requirements, see Section 7.

## 2.1.5. Fixed Measure - Direct Part Marking

### **Application Description**

Direct part marking (DPM) refers to the process of marking a symbol on an item using an intrusive or non-intrusive method.

### **GS1 Key**

#### **Definition**

GTIN-12, -13, -14 (see Section 3).

#### **Rules**

GTIN Allocation rules are described in Section 4.

### **Attributes**

#### **Required**

Not Applicable

#### **Optional**

See Section 3 for all the Application Identifiers (AIs) that can be used with a GTIN. Since the GTIN identifies a grouping of items, the optional attributes apply to the grouping as well.

**Rules**

All the GTIN Allocation Rules described in Section 4.

**Data Carrier Specification**

**Carrier Choices**

The use of GS1 DataMatrix in direct part marking applications is endorsed by GS1 for those applications that require permanent marking for cradle-to-grave history of the part's lifecycle.

Some sources express the height of the 2D cell in terms of a Y dimension. For GS1 DataMatrix the cells are considered the same size under optimal print conditions so that X = Y.

Consult System Symbol Specification Table 7: 2D Symbols Using GS1 DataMatrix, Figure 5.5.2.7 - 8, for minimum and maximum printing densities and other sizing requirements.

Symbol size is determined by the amount of data and the number of rows and columns required encoding the data for the printing density selected (see Figures 5.7.3.2 - 1 and 5.7.3.2 - 2).

**Figure 2.1.5 - 1**  
**Example of GS1 DataMatrix Symbol Encoded with GTIN and AIs (17) and (10) per Section 2.1.3**

(17) 050101 (10) ABC123



(01) 04012345678901

**Figure 2.1.5 - 2**  
**Example of GS1 DataMatrix Symbol Encoded with GTIN and Serial Number AI (21)**

(21) ABCDEFG123456789



(01) 04012345678901

**Symbol Placement**

General principles on placement of bar codes are described in Section 6.

The majority of uses for these symbols will be on very small items with curved surfaces such as vials, ampoules, and very small bottles. For guidance in locating these symbols on curved surfaces, refer to Section 6.2.3.2.

**Unique Application Processing Requirements**

Use GS1 DataMatrix if:

- The use of GS1 DataMatrix is allowed in the application specification.
- The marking method will not produce an acceptable linear symbol but will produce an acceptable GS1 DataMatrix (e.g., dot peen marking and high-speed ink jet).

- A GS1 Identification Key plus attribute Element String are to be encoded
- GS1 DataMatrix is the only symbology that will fit on the item at the application specified X-dimension.
- Low contrast signal is expected from the application.
- The use of 2D (two-dimensional) array scanners and/or vision systems are specified exclusively for the application and can read GS1 DataMatrix.

### ***Marking Methods***

It is important to analyse the selected method of marking in relation to several considerations:

- Finishes that cause an excess of shadowing or glare
- Surfaces that do not provide sufficient contrast - less than 20 percent difference in surface reflectance
- Safety critical parts that can not be marked with intrusive methods
- Marking method must comply with the users requirements
- Location of the symbol should not be:
  - In direct air/water (streams, etc.)
  - On sealing surfaces
  - On surfaces subject to wear or exposure to heavy contact

### ***Intrusive (Subtractive Methods)***

Intrusive marking refers to methods that remove or alter the material of the host.

- Abrasive blast
- Dot peen
- Electro-chemical marking, colouring, or etching
- Engraving/milling
- Fabric embroidery/weaving
- Direct laser marking
- Laser shot peening
- Laser Inducted Surface Improvement (LISI)
- Gas Assisted Laser Etch (GALE)
- Laser Induced Vapor Deposition (LIVD)

### ***Non-Intrusive (Additive Methods)***

Non-Intrusive marking does not affect the host material; it usually involves the addition of material.

- Cast, forge, mold
- Inkjet
- Laser bonding
- Liquid metal jet
- Silk screen
- Stencil

**Host (Substrate) Surface**

Direct part marking of GS1 DataMatrix should be reserved for surfaces no rougher than 250 micro inches (millionths of an inch) and for surfaces that are no smoother than 8 micro inches. Surfaces that fall outside these parameters need to be re-surfaced or marked using an alternative method.

Consideration of the surface colour must be taken. A minimum 20 percent difference in contrast between the host and the symbol is required.

Altering the cell size in relation to the surface roughness should provide adequate contrast on cast surfaces.

(Cell size = (0.00006 X roughness) + 0.0067); (see Figure 2.1.5 - 3)

**Figure 2.1.5 - 3**

Average Roughness	Cell Size Minimum
0,508 micrometers (20 micro inches)	0.1905 mm (0.0075 in.)
1,524 micrometers (60 micro inches)	0.2286 mm (0.009 in.)
3,048 micrometers (120 micro inches)	0.381 mm (0.015 in.)
5,08 micrometers (200 micro inches)	0.508 mm (0.020 in.)
7,62 micrometers (300 micro inches)	0.635 mm (0.025 in.)
10,668 micrometers (420 micro inches)	0.762 mm (0.030 in.)

**Substrate Surface Thickness**

A minimum host surface thickness is recommended as is a maximum marking depth. Both are outlined in the table below.

**Figure 2.1.5 - 4**

Method	Min. Thickness	Max Marking Depth
Dot Peen	1.016 mm (0.04 in.)	0.102 mm (0.004 in.)
Laser Shot peening	0.508 mm (0.020 in.)	0.051 mm (0.002 in.)
Laser Bonding	0.025 mm (0.001 in.)	Surface Mark
Abrasive Blast	0.076 mm (0.003 in.)	0.008 mm (0.0003 in.)
Electro-Chemical Colouring	0.508 mm (0.02 in.)	0.051 mm (0.002 in.)
Laser Etch	0.762 mm (0.03 in.)	0.076 mm (0.003 in.)
LISI	1.016 mm (0.04 in.)	0.102 mm (0.004 in.)
Laser Engraving	1.27 mm (0.05 in.)	0.127 mm (0.005 in.)
Electro-Chemical Etch	2.54 mm (0.100 in.)	0.254 mm (0.01 in.)
Micro-Milling	31.75 mm (1.250 in.)	3.175 mm (0.125 in.)

**Human Readable Interpretation**

■ **Location**

If printed, the GTIN shall be printed in Human Readable Interpretation underneath the symbol. If there is sufficient space to print the Human Readable Interpretation of the optional attribute data, it shall be printed above the symbol in proper sequence of the Application Identifiers. The data shall be printed from top to bottom and left to right. A single Application Identifier with accompanying data shall be displayed on one line and not broken into two lines.

### ■ Font

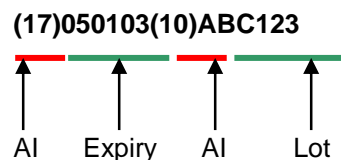
A clearly legible font shall be used for the human-readable digits (e.g., OCR-B as defined in *ISO 1073-2*). Reasonable alternative type fonts and character sizes are acceptable provided the interpretation is clearly legible. The font should be one that is considered suitable and compatible with other printed materials. When necessary, the font used shall be in accordance with applicable government laws and regulations.

### ■ Format

The GTIN shall be printed as a single 14-digit number preceded by the corresponding Application Identifier (01) enclosed in a parenthesis.



The data should be printed with the preceding AI's enclosed in parenthesis. The order of the data should be the same as encoded in the GS1 DataMatrix symbol according to the rules in these *GS1 General Specifications*. The parentheses are not part of the data and are not encoded in the bar code symbol, though the AIs are.



### ■ Symbol Quality

The minimum symbol quality grade for GS1 DataMatrix Symbols shall be specified by the application specification. The measurement of the quality parameters shall be made by a verifier conforming to *ISO/IEC 15415*. According to this standard an overall grade is shown in the form:

**Grade/Aperture/Light/Angle**

#### Where:

- "Grade" is the overall symbol grade as defined in *ISO/IEC 15415* Information technology - Automatic identification and data capture techniques - Bar code symbol print quality test specification - Two-dimensional symbols (e.g., the arithmetic mean to one decimal place of the Scan Reflectance Profile or scan grades). For GS1 DataMatrix, the grade number may be followed by an asterisk, \*, which indicates that the surroundings of the symbol contain extremes of reflectance that may interfere with reading. For most applications, this should be specified as causing the symbol to fail.
- "Aperture" is the diameter in thousandths of an inch (to the nearest thousandth) of the synthetic aperture defined in *ISO/IEC 15415* Information technology - Automatic identification and data capture techniques - Bar code symbol print quality test specification - Two-dimensional symbols.
- "Light" defines the illumination: A numeric value indicates the peak light wavelength in nanometers (for narrow band illumination); the alphabetic character W indicates that the symbol has been measured with broadband illumination ("white light"), the spectral response characteristics of which must imperatively be defined or have their source specification clearly referenced.

- "Angle" is an additional parameter defining the angle of incidence (relative to the plane of the symbol) of the illumination. It shall be included in the reporting of the overall symbol grade when the angle of incidence is other than 45 degrees. Its absence indicates that the angle of incidence is 45 degrees.
- ✔ **Note:** This international standard provides for 30 degrees and 90 degrees illumination in addition to the default 45 degrees.

The aperture is normally specified as being 80 percent of the minimum X-dimension allowed for the application. The printing method must produce the GS1 DataMatrix "L" pattern with gaps between the dots less than 25 percent of the specified aperture. If symbols with greater than the minimum X dimension are allowed by the application, the same absolute maximum gap dimension must be maintained.

### **Scanning Requirements**

Direct Part Marked Items require the use of a two-dimensional imaging scanner or vision system designed specifically to read the DPM symbols. Scanners designed to read other products will not read DPM symbols.

### **References**

The standards listed below are referenced in these guidelines. The relevant provisions contained in the referenced specifications constitute provisions of these guidelines.

- ISO/IEC 16022** Information Technology- International Symbology Specification – GS1 DataMatrix
- ISO/IEC 15415** Information technology – Automatic identification and data capture techniques – Bar code print quality test specification – 2D symbols
- ISO/IEC 15416** Information technology – Automatic identification and data capture techniques – Bar code print quality test specification – linear symbols
- ISO 1073-2** Alphanumeric character sets for optical recognition – Part 2: Character set
- OCR-B** Shapes and dimensions of the printed image

## **2.1.6. Variable Measure Trade Items Not Crossing a Point-of-Sale**

### **Application Description**

Trade items may be of variable measure either because the production process does not guarantee consistency in weight, size, or length (e.g., carcasses of meat, whole cheeses) or because the items are created to meet a special order that states a quantity (e.g., textiles ordered by the metre, glass ordered by the square metre).

Only trade items that are sold, ordered, or produced in quantities, which can vary continuously, are covered by the rules outlined in this section. Trade items that are sold in discrete and pre-defined bands (e.g., as a nominal weight) are treated as Fixed Measure Trade Items.

A trade item must be considered a Variable Measure Trade Item if its measure is variable at any point in the supply chain. For example, a supplier may sell and invoice chickens in standardised cases of 15 kilograms each; therefore, the quantity of contained chickens will vary. The customer, a retailer in this example, may need to know the exact number of chickens contained in each case in order to organise the distribution to his stores. In this example, the supplier should source mark the trade item by using a variable measure Global Trade Item Number (GTIN) and the variable count Element String.

See Section 3 for the use of AI (242) Variable Made-to-Order Number and its use in the Maintenance, Repair and Operations (MRO) industrial supply sector.

**Figure 2.1.6 - 1**

		<b>Format of the Element String</b>													
		Global Trade Item Number (GTIN)													
Indicator		GS1 Company Prefix						Item Reference						Check Digit	
		→						←							
(GTIN-12)	9	0	N <sub>3</sub>	N <sub>4</sub>	N <sub>5</sub>	N <sub>6</sub>	N <sub>7</sub>	N <sub>8</sub>	N <sub>9</sub>	N <sub>10</sub>	N <sub>11</sub>	N <sub>12</sub>	N <sub>13</sub>	N <sub>14</sub>	
(GTIN-13)	9	N <sub>2</sub>	N <sub>3</sub>	N <sub>4</sub>	N <sub>5</sub>	N <sub>6</sub>	N <sub>7</sub>	N <sub>8</sub>	N <sub>9</sub>	N <sub>10</sub>	N <sub>11</sub>	N <sub>12</sub>	N <sub>13</sub>	N <sub>14</sub>	

The Check Digit is explained in Section 7.10. Its verification, usually carried out automatically by the bar code reader, ensures that the number is correctly composed. The symbology identifier shows whether or not the Check Digit has been validated. If it has not, the Check Digit verification must be programmed in the application software.

Any trade item of a given composition where the quantity/measure information cannot be pre-determined for any reason is a Variable Measure Trade Item. The most frequent types are shown in Figure 2.1.6 - 2.

**Figure 2.1.6 - 2**

Type	Item Description
<b>A</b>	Items traded in bulk, neither portioned nor pre-packed for retail sale, ordered in any quantity, and that are delivered as non-standardised trade items (e.g., fish, fruit, vegetables, cables, carpets, timber, fabrics) The identification number denotes the item as a trade entity containing any quantity of the given product and, if applicable, the form of packaging. Weight or dimensions complete the identification of the individual unit.
<b>B</b>	Trade items ordered and delivered by piece (wrapped or unwrapped) and invoiced by weight or measure because weight or measure varies due to the nature of the product or due to the manufacturing process (e.g., whole cheese, sides of bacon, beef carcasses, fish, sausages, ham, chicken, cauliflower, motion picture films) The identification number denotes the item as a particular pre-defined entity and, if applicable, denotes the form of packaging. Price or weight or dimensions complete the identification of the individual item.
<b>C</b>	Portioned trade items, pre-packed for sale by weight to the consumer, not standardised in quantity. (e.g., meat, cheese, vegetables, fruit, fillets of fish, sliced poultry, cold cuts) The identification number denotes the item type according to business practice and the form in which it is packed. Price or weight completes the identification of the individual unit.
<b>D</b>	Standardised trade items with selectable dimensions where GS1 System standard numbering does not make sense to cover the multiplicity of all variations (e.g., wooden planks, carpeting) The identification number denotes the pre-defined basic trade item. The applicable dimension(s) completes the identification of the individual unit.
<b>E</b>	Standardised composition of a fixed number of trade items that are Type B or Type C (e.g., a trade item containing 10 chickens (Type B)) The identification number denotes the standardised trade item as an entity and, if applicable, its form of packaging. The total weight of all items contained completes the identification of the particular trade item.
<b>F</b>	Trade items made to customer specifications, restricted in use to the Maintenance, Repairs and Operations industrial supply sector, and sold business-to-business. The identification number denotes a base custom item. The specific variation is identified by the Variation Made-to-Order Number. (See in Section 3.2 the List for all GS1 Application Identifier).

## GS1 Key

### Definition

The GTIN-14 is the 14-digit GS1 Identification Key composed of an Indicator digit (9), GS1 Company Prefix, Item Reference, and Check Digit used to identify trade items.

### Rules

The GTIN-14 with the Indicator 9 is used to identify a Variable Measure Trade Item. The presence of the variable measure information is mandatory for the complete identification of a particular Variable Measure Trade Item. The digit 9 in the first position is an integral part of the GTIN.

The GTIN-14 Data Structure beginning with Indicator 9 is not used on an item intended to cross the Point-of-Sale. Numbering of these items is defined in Section [2.1.2.3](#).

### Attributes

#### Required

The GTIN-14 identifies a Variable Measure Trade Item with respect to its fixed attributes or characteristics. To complete the identification of a Variable Measure Trade Item, the presence of an Element String representing a trade measure is mandatory.

See in Section 3.2 the List for all GS1 Application Identifier, Identification of a Variable Measure Trade Item (GTIN): AI (01).

#### Optional

Applicable trade measures depend on the nature of the product. They may be a quantity, a weight, or any dimension.

- An Element String with Application Identifier (30) is used if the variable measure of the trade item is the number of items contained. In order to generate a short bar code symbol, always enter an even number of digits in the data field count of items by inserting a leading zero. Concatenation of this Element String with the GTIN of the item enhances the accuracy of the application (see in Section 3.2 the List for all GS1 Application Identifier, Variable Count: AI (30)).
- An Element String with Application Identifiers (AIs) (31nn), (32nn), (35nn), and (36nn) is used if the variable measure of the respective trade item is weight, dimension, area, or volume. Only one Element String of a given unit of measure may be applied on a particular item. Several Element Strings containing trade measures are possible on a particular item if the item is available in either unit of measure and if the applicable unit of measure is not distinguished for ordering and billing. This might apply if weight must be expressed in kilograms and pounds (see in Section 3.2 the List for all GS1 Application Identifier, Trade Measures: AIs (31nn, 32nn, 35nn, 36nn)).
- ✓ **Note:** The fourth (and last) digit of the AI indicates the implied decimal point position. The value 0 means that the measurement is expressed in the basic unit of measure associated with the AI (e.g., kilograms). A value of 1 decreases the measurement by a factor of 10, a value of 2 by a factor of 100, and so on. For example, this enables metric weights to be represented from 999 kilograms to 1/1000 of a milligram.
- An Element String with Application Identifier (8001) contains the pre-defined variable fields of a roll product and it may be used for those variable roll products where the standard trade measures AI (31nn), (32nn), (35nn), (36nn)) are not sufficient. The GTIN-14 can denote a basic roll product.

### **Rules**

An Element String with Application Identifier (30) should never be used to indicate the quantity contained in a Fixed Measure Trade Item. However, if it appears on a Fixed Measure Trade Item, it should not invalidate the trade item identification.

An Element String with Application Identifier (8001) must never be used together with other Element Strings representing standard trade measures.

### **Data Carrier Specification**

#### **Carrier Choices**

Variable Measure Trade Items not crossing a Point-of-Sale should be marked with an ITF-14 Bar Code Symbol or GS1-128 Bar Code Symbolology.

#### **Symbol X-Dimensions, Minimum Symbol Height, and Minimum Symbol Quality**

See Section 5.5, Figure 5.5.2.7 – 4, GS1 System Symbol Specification Table 3.

#### **Symbol Placement**

All the Symbol Placement Guidelines defined in Section 6.

### **Unique Application Processing Requirements**

For a description of processing requirements, see Section 7.

### **Examples of Variable Measure Trade Item Numbering and Symbols**

In the examples in the subsections that follow, the following factors apply:

- In order to be illustrative, all examples show the same presentation (e.g., price list, order, delivery, invoice, and recording in a data file).
- GS1-128 Bar Code Symbols are used.
- The examples are given to demonstrate the correct use of a given Application Identifier when used. When AI (02) is not used, information about the shipment must be received using Electronic Data Interchange (EDI) or other means prior to its physical receipt.

#### **Example 1: Traded by Piece**

The following example shows the order and delivery of an item traded by piece and invoiced by weight.

- The supplier's catalogue contains one entry: one salami weighing ~ 500 grams
- The order for 100 units is delivered in three boxes. Each box is marked with an SSCC (Serial Shipping Container Code) and, optionally, with information on the content of the box, expressed as follows:
  - AI (02) indicates the variable measure Global Trade Item Number (GTIN) of the units contained within the box.
  - AI (3101) indicates the total weight of the items contained within the box.
  - AI (37) indicates the count of items contained within the box.
- The three boxes may be stored on a pallet that may itself be marked with an SSCC and, optionally, with information on the contents of the pallet, expressed as follows:
  - AI (02) indicates the variable measure GTIN of the units contained within the pallet.
  - AI (3101) indicates the total weight of the items contained within the pallet.
  - AI (37) indicates the count of items contained within the pallet.

The invoice refers to the GTIN and quantity delivered and shows the total weight and the price per kilogram. The GTIN and quantity of the invoice match the GTIN and quantity of the order.

**Figure 2.1.6 - 3**

Process	Description	Element Strings Used / Symbol Marking of the Items
Supplier's catalogue	1 Salami ~ 500 GRM	GTIN 97612345000018
Order	100 salamis	100 x 97612345000018
Delivery	three logistic units Unit 1 = 33 salamis, 16.7 KGM Unit 2 = 33 salamis, 16.9 KGM Unit 3 = 34 salamis, 17.1 KGM	Unit 1: 00 376123450000010008 02 97612345000018 3101 000167 37 33 Unit 2: 00 376123450000010015 02 97612345000018 3101 000169 37 33 Unit 3: 00 376123450000010022 02 97612345000018 3101 000171 37 34
	If delivery is made on a pallet	Pallet: 00 376123450000010039 02 97612345000018 3101 000507 37 0100
Invoice	GTIN of items and the total weight (50.7 KGM) + the price per KGM	100 x 97612345000018; 50.7 KGM x price per KGM

Data File Logistic Units	Identification of Logistic Unit (SSCC)	GTIN of Contained Trade Items	Total Trade Weight of Content (Grams)	Number of Units Contained
Either pallet	376123450000010039	97612345000018	50700	100
or individual units	376123450000010008	97612345000018	16700	33
	376123450000010015	97612345000018	16900	33
	376123450000010022	97612345000018	17100	34

Data File Trade Items	GTIN of Trade Item	Total Trade Weight (Grams)	Number of Trade Items
One record per identification number	97612345000018	50700	100

An Element String with an Application Identifier (410) represents the Global Location Number (GLN) of the recipient of a logistic unit. The GLN refers to the address where a particular consignment is to be delivered. This Element String is used in single leg transport operations. A logistic unit may include a bar code symbol carrying the GLN of the unit's intended destination. When scanning this Element String, the data transmitted may be used to retrieve the related address and/or to sort the item by destination.

**Example 2: Traded by Standard Grouping**

The following example shows the order and delivery of an item traded by standard grouping and invoiced by weight.

- The supplier's catalogue contains one entry: one case of 20 steaks weighing ~ 200 grams each.
- The order is for three cases. Each case delivered is marked with the Global Trade Item Number (GTIN) of a single case followed by the actual weight of the items contained.

- The three cases may be stored on a pallet that may itself be marked with an SSCC (Serial Shipping Container Code) and, optionally, with information on the contents of the pallet, expressed as follows:
  - AI (02) indicates the variable measure GTIN of the units contained within the pallet.
  - AI (3102) indicates the total weight of the items contained within the pallet.
  - AI (37) indicates the count of cases contained within the pallet.
- The invoice refers to the GTIN and quantity delivered and shows the total weight and the price per kilogram. The GTIN and quantity of the invoice match the GTIN and quantity of the order.

**Figure 2.1.6 - 4**

Process	Description	Element Strings Used / Symbol Marking of the Items
Supplier's catalogue	1 case of 20 steaks ~ 200 GRM vacuum packed	GTIN 97612345000117
Order	Three cases	3 x 97612345000117
Delivery	Three trade items Unit 1: weight = 4.150 KGM Unit 2: weight = 4.070 KGM Unit 3: weight = 3.980 KGM	Unit 1: 01 97612345000117 3102 000415 Unit 2: 01 97612345000117 3102 000407 Unit 3: 01 97612345000117 3102 000398
	If delivery is made on a pallet	Pallet: 00 376123450000010091 02 97612345000117 3102 001220 37 03
Invoice	GTIN of items and the total weight (12.20 KGM) + the price per KGM	3 x 97612345000117; 12.2 KGM x price per KGM

Data File Logistic Units	Identification of Logistic Unit (SSCC)	GTIN of Contained Trade Items	Total Trade Weight of Content (Grams)	Number of Units Contained
Pallet	376123450000010091	97612345000117	12200	3

Data File Trade Items	GTIN of Trade Item	Total Trade Weight	Number of Trade Items
One Record	97612345000018	12200	3

**Example 3: Traded in Bulk**

The following example shows an order and delivery of an item traded in bulk.

- The supplier's catalogue contains one entry: cabbage unwrapped sold in bulk by kilogram.
- The order is for 100 kilograms. It is delivered in two cases. Each case is marked with the Global Trade Item Number (GTIN) of the cabbage followed by the actual weight of the items contained.
- The two cases may be stored on a pallet that may itself be marked with an SSCC (Serial Shipping Container Code).
- The invoice refers to the GTIN as ordered and shows the total weight and the price per kilogram. The delivered weight may be verified as being close to the ordered quantity.

**Figure 2.1.6 - 5**

Process	Description	Element Strings Used / Symbol Marking of the Items
Supplier's catalogue	Cabbage unwrapped sold in bulk by kilogram	GTIN 97612345000049
Order	100 KGM of cabbage	100 KGM x 97612345000049
Delivery	Two trade items Unit 1: weight = 42.7 KGM Unit 2: weight = 57.6 KGM	Unit 1: 01 97612345000049 3101 000427 Unit 2: 01 97612345000049 3101 000576
	If delivery is made on a pallet	Pallet: 00 376123450000010107
Invoice	GTIN of item and the total weight (100.3 KGM) + the price per KGM	97612345000049 100.3 KGM x price per KGM

Data File Logistic Units	Identification of Logistic Unit (SSCC)	GTIN of Contained Trade Items	Total Trade Weight of Content (Grams)	Number of Units Contained
Pallet	376123450000010107	97612345000049	42700	1
		97612345000049	57600	1

Data File Trade Items	GTIN of Trade Item	Total Trade Weight (Grams)	Number of Trade Items
One record per trade item	97612345000049	42700	1
	97612345000049	57600	1

**Example 4: Traded by Standard Grouping**

The following example shows an order of standardised Variable Measure Trade Items by case that are invoiced by the number of pieces delivered.

- The supplier's catalogue contains one entry: one case of ~ 10 cabbages sold by piece.
- The order is for two cases. Each case delivered is marked with the Global Trade Item Number (GTIN) of a single case followed by the actual count of the items contained.
- The two cases may be stored on a pallet that may itself be marked with an SSCC (Serial Shipping Container Code) and, optionally, with information on the contents of the pallet, expressed as follows:
  - AI (02) indicates the variable measure GTIN of the units contained within the pallet.
  - AI (30) indicates the total count of the items contained within the pallet.
  - AI (37) indicates the count of cases contained within the pallet.
- The invoice refers to the GTIN as ordered and delivered and the total count of items.

**Figure 2.1.6 - 6**

Process	Description	Element Strings Used / Symbol Marking of the Items
Supplier's catalogue	Case containing ~10 cabbages sold by pieces	GTIN 97612345000285
Order	Two cases	2 x 97612345000285
Delivery	Unit 1: 11 pieces Unit 2: 12 pieces	Unit 1: 01 97612345000285 30 11 Unit 2: 01 97612345000285 30 12
	If delivery is made on a pallet	Pallet: 00 376123450000010138 02 97612345000285 30 23 37 02
Invoice	GTIN of the trade item and the total quantity	2 x 97612345000285 23 pieces x price per piece

Data File Logistic Units	Identification of Logistic Unit (SSCC)	GTIN of Contained Trade Items	Total Number of Pieces Contained in the Trade Item	Number of Units Contained
Pallet	376123450000010138	97612345000285	23	2

Data File Trade Items	GTIN of Trade Item	Total Number of Pieces	Number of Trade Items
One Record	97612345000285	23	2

**Example 5: Traded in Bulk**

The following example shows a product that can be purchased from a supplier or sold to a customer by any length in metres.

- The supplier's catalogue contains one entry: cable T49 sold in metres.
- The order is for one length of cable of 150 metres. The delivered package is marked with the Global Trade Item Number (GTIN) of the cable followed by the actual length of cable contained.
- The invoice refers to the GTIN as ordered and delivered and the total length.

**Figure 2.1.6 - 7**

Process	Description	Element Strings Used / Symbol Marking of the Items
Supplier's catalogue	Cable T49 sold in any length in MTR	GTIN 97612345000063
Order	One trade item of 150 MTR	97612345000063 x 150 MTR
Delivery	One trade item, 150 MTR	01 97612345000063 3110 000150
Invoice	GTIN of the trade item and the total quantity	1 x 97612345000063 150 x price per MTR

Data File Trade Items	GTIN of Trade Item	Total Trade Length (Metres)
One record	97612345000063	150

### 2.1.7. Fixed Measure – Restricted Distribution

This section describes applications where the item identification is defined only in a closed environment. Therefore, the distribution of trade items marked in this way is restricted to a given geographic region or for use within a company. However, within their closed environment these items may be processed along with trade items identified with Global Trade Item Numbers (GTINs) defined for open trade.

The regulations established by GS1 Member Organisations for their country or assigned area should be observed for the allocation of these Restricted Circulation Numbers.

When assigned to company internal use, the structure and management of the numbers represented in the Element Strings of this section are the responsibility of the user. Number changes and re-use of expired numbers must be managed by the user based on his requirements.

When centrally administrated within a geographic area, the GS1 Member Organisation determines the structure and manages number allocation based on user requirements.

These identification numbers are known as Restricted Circulation Numbers and may be 8, 12, or 13 digits in length. Eight-digit numbers are known as RCN-8s, 12-digit numbers as RCN-12s, and 13-digit numbers as RCN-13s.

Restricted circulation Fixed Measure Trade Items are defined only in a closed environment. Therefore, the distribution of trade items marked in this way is restricted to a given geographic region or for use within a company. These items are either marked in the store by the retailer or are marked at the source by the supplier.

GS1 Member Organisations may assign one or several of the GS1 Prefixes 02, 20 through 29 for the identification of Fixed Measure Trade items with RCN-13s, or RCN-12s for use within a given geographic region or for use within a company.

#### 2.1.7.1. Company Internal Numbering – RCN-8 Prefix 0 or 2

##### Application Description

This Element String uses an RCN-8 Prefix of 0 or 2. It provides two million identification numbers, which can be assigned for internal use in a company. When the RCN-8 Prefix is 0, the Element String is sometimes called a Velocity Code because it is quicker to key enter.

This Element String is for internal use in a company. The numbers are assigned by individual companies and do not provide unique identification if they leave the company premises.

Figure 2.1.7.1 - 1

Format of the Element String							
RCN-8 Prefix	Item Reference						Check Digit
N1	N2	N3	N4	N5	N6	N7	N8

The RCN-8 Prefixes 0 or 2 are system identifiers that show that the item identification number is under the sole control of the assigning company and that it is for internal item distribution.

The Item Reference is allocated by the company that uses the Element String. The positions N2 to N7 may contain any digit.

The Check Digit is explained in Section 7.10. Its verification, carried out automatically by the bar code reader, ensures that the number is correctly composed.

The data transmitted from the bar code reader means that one Fixed Measure Trade Item with a GTIN-8 has been captured.

- Note:** In addition to trade item identification, this Element String may be used for any purpose that is supported by the company's equipment supplier.
- Note:** In some environments where numbers may have to be key entered, the EAN-8 Bar Code Symbol carrying RCN-8s (and the RCN-8 Prefix 0) may be confused with the numbers carried by a UPC-E Bar Code Symbol. If such a risk exists, it is preferable to use the RCN-8 Prefix 2 capacity for internal use.

**GS1 Key**

**Definition**

Not Applicable

**Rules**

Not Applicable

**Attributes**

**Required**

Not Applicable

**Optional**

Not Applicable

**Rules**

Not Applicable

**Data Carrier Specification**

**Carrier Choices**

The data carrier for this Element String is the EAN-8 Bar Code Symbol. The system recognises this Element String by the symbology identifier **JE4** and by N1 being 0 or 2.

**Symbol X-Dimensions, Minimum Symbol Height, and Minimum Symbol Quality**

See Section 5.5, Figure 5.5.2.7 – 2, GS1 System Symbol Specification Table 1.

**Symbol Placement**

Not Applicable

**Unique Application Processing Requirements**

Not Applicable

**2.1.7.2. Company Internal Numbering – RCN-13 GS1 Prefix 04 (RCN-12 U.P.C. Prefix 4)**

**Application Description**

Any company in the world may use this Element String for company internal trade item numbering. If the RNC-12 U.P.C. Prefix 4 is being applied, the user company may structure the trade item number.

Although this Element String is mainly used for the identification of trade items, it may be used for any purpose as long as it is kept within a restricted environment.

This Element String is for a company’s internal use. Because any company may use this Element String, it does not provide unique identification of a trade item if it leaves the company’s premises.

**Figure 2.1.7.2 - 1**

Format of the Element String												
GS1 Prefix		Item Reference										Check Digit
0	4	N3	N4	N5	N6	N7	N8	N9	N10	N11	N12	N13

The GS1 Prefix 04 is a system identifier showing that the identification number is under the sole control of the assigning company and that it is for internal trade item distribution.

The Item Reference is assigned by the company that uses the Element String. Positions N3 to N12 may contain any digit.

The Check Digit is explained in Section 7.10. Its verification, carried out automatically by the bar code reader, ensures that the number is correctly composed.

The data transmitted from the bar code reader means that one Fixed Measure Trade Item with a GTIN-13 has been captured.

**GS1 Key**

**Definition**

Not Applicable

**Rules**

Not Applicable

**Attributes**

**Required**

Not Applicable

**Optional**

Not Applicable

**Rules**

Not Applicable

## Data Carrier Specification

### **Carrier Choices**

The data carrier for this Element String is the UPC-A Bar Code Symbol.

The system recognises this Element String by the symbology identifier **JE0**.

### **Symbol X-Dimensions, Minimum Symbol Height, and Minimum Symbol Quality**

See Section 5.5, Figure 5.5.2.7 – 2, GS1 System Symbol Specification Table 1.

### **Symbol Placement**

Not Applicable

### **Unique Application Processing Requirements**

Not Applicable

## 2.1.7.3. Company Internal Numbering – RCN-12 UPC Prefix 0 (LAC and RZSC)

### **Application Description**

The UPC Company Prefix 0 includes a reserved capacity for company internal numbering, using Local Assigned Codes (LACs) or Retailer Zero-Suppression Codes (RZSCs), which are carried by a UPC-E Bar Code Symbol. UPC Company Prefixes 000000 and 001000 to 007999 are used in this feature. For details, see Figure 2.1.7.3 – 1.

Although this Element String is mainly used for the identification of trade items in restricted distribution, it may be used for any purpose as long as it is kept within a restricted environment.

This Element String is for a company's internal use. Because any company may use this Element String, it does not provide unique identification of a trade item if it leaves the company's premises.

Figure 2.1.7.3 - 1

UPC-E Bar Code Symbol Option for the Identification of GTINs for Company Internal Distribution

GTIN-12 Identification Number of Trade Item											Check Digit	Represented in UPC-E Symbol Positions						
N <sub>1</sub>	N <sub>2</sub>	N <sub>3</sub>	N <sub>4</sub>	N <sub>5</sub>	N <sub>6</sub>	N <sub>7</sub>	N <sub>8</sub>	N <sub>9</sub>	N <sub>10</sub>	N <sub>11</sub>	N <sub>12</sub>	1	2	3	4	5	6	
(0)	0	0	1	0	0	0	0	0	0	0	5	2	0	1	0	0	0	'5'
(0)	0	<u>0</u>	<u>7</u>	<u>9</u>	<u>9</u>	<u>9</u>	0	0	0	0	<u>9</u>	7	<u>0</u>	<u>7</u>	<u>9</u>	<u>9</u>	<u>9</u>	'9'
LAC version = 35000 UPC-E Bar Code Symbol Applications																		
(0)	0	0	1	0	0	0	0	0	1	0	0	4	0	1	1	0	0	'0'
(0)	0	<u>0</u>	<u>5</u>	<u>0</u>	0	0	0	0	<u>9</u>	<u>9</u>	<u>9</u>	2	<u>0</u>	<u>5</u>	<u>9</u>	<u>9</u>	<u>9</u>	'0'
RZSC version = 4500 UPC-E Bar Code Symbol Applications																		
(0)	0	0	0	0	0	0	0	0	0	0	0	0	0	0	0	0	0	'0'
(0)	0	<u>0</u>	<u>0</u>	<u>0</u>	0	0	0	0	<u>9</u>	<u>9</u>	<u>9</u>	7	<u>0</u>	<u>0</u>	<u>9</u>	<u>9</u>	<u>9</u>	'0'
Velocity version = 1000 UPC-E Bar Code Symbol Applications																		

In Figure 2.1.7.3 - 1, each number position must only contain the digits shown in the upper and lower lines of each section and those in-between. On decoding, the extension to full length is determined by the value of the number in single quotes in the column represented in UPC-E Bar Code Symbol positions.

The Check Digit, calculated as described in Section 7.10, applies to the entire length of the RCN-12. In the UPC-E Bar Code Symbol, it is implicitly represented by the parity combination of the six symbol characters that are actually encoded. The Check Digit is explained in Section 7.10. Its verification, carried out automatically by the bar code reader, ensures that the number is correctly composed

**GS1 Key**

**Definition**

Not Applicable

**Rules**

Not Applicable

**Attributes**

**Required**

Not Applicable

**Optional**

Not Applicable

**Rules**

Not Applicable

**Data Carrier Specification****Carrier Choices**

The data carrier for this Element String is the UPC-A Bar Code Symbol.

The system recognises this Element String by the symbology identifier **JE0** and GS1 Prefix 00 with the digits 01 to 07 in the next two positions.

**Symbol X-Dimensions, Minimum Symbol Height, and Minimum Symbol Quality**

See Section 5.5, Figure 5.5.2.7 – 2, GS1 System Symbol Specification Table 1.

**Symbol Placement**

Not Applicable

**Unique Application Processing Requirements**

It is possible to create false UPC-E Bar Code Symbols if the encodation rules are not properly observed. Whether the digits represented in a UPC-E Bar Code Symbol can be expanded correctly to an RCN-12 may be verified by the tests shown in section 7.11.

**2.1.7.4. GS1 Prefixes 02, 20 to 29 - Restricted Circulation****Application Description**

The GS1 Prefixes 02, 20 to 29 are reserved for identification purposes within a restricted geographic area. Each GS1 Member Organisation is entitled to assign the prefixes to be used for these Element Strings in its country or assigned area:

- For the identification of Variable Measure Trade Items or Fixed Measure Trade Items
- For internal numbering of Variable Measure Trade Items or Fixed Measure Trade Items by a particular company



**Note:** Suppliers manufacturing their own label products for several different customers should use unique GS1 System numbering to distinguish their customers. If this is not done, the supplier will not be able to use Electronic Data Interchange (EDI) or electronic catalogues.

Although this Element String is mainly used for the identification of trade items, it may be used for any purpose as long as it is kept within a restricted environment.

This Element String is for use within a GS1 Member Organisation's geographic region. The GS1 Member Organisation may assign a company a GS1 Prefix for use externally throughout a region or may assign the prefix for use internally within a region. The numbers are never unique if they leave the region and, if assigned for a company's internal use, are not unique if they leave the company or region.

Figure 2.1.7.4 - 1

Format of the Element String												
GS1 Prefix		Item Reference										Check Digit
2	N <sub>2</sub>	N <sub>3</sub>	N <sub>4</sub>	N <sub>5</sub>	N <sub>6</sub>	N <sub>7</sub>	N <sub>8</sub>	N <sub>9</sub>	N <sub>10</sub>	N <sub>11</sub>	N <sub>12</sub>	N <sub>13</sub>

The GS1 Prefix must be in the series 20 to 29. A particular prefix may be assigned either for use on Fixed Measure Trade Items for restricted distribution or for Variable Measure Trade Items (see Section [2.1.8](#)).

The Item Reference is assigned by the company that uses the Element String. Positions N<sub>3</sub> to N<sub>12</sub> may contain any digit.

The Check Digit is explained in Section 7.10. Its verification, carried out automatically by the bar code reader, ensures that the number is correctly composed.

The data transmitted from the bar code reader means that one Fixed Measure Trade Item with a GTIN-13 has been captured.

**GS1 Key**

**Definition**

Not Applicable

**Rules**

Not Applicable

**Attributes**

**Required**

Not Applicable

**Optional**

Not Applicable

**Rules**

Not Applicable

**Data Carrier Specification**

**Carrier Choices**

The data carrier for this Element String is an EAN-13 Bar Code Symbol.

The system recognises this Element String by the symbology identifier **JE0** and the GS1 Prefix assigned by the relevant GS1 Member Organisation.

**Symbol X-Dimensions, Minimum Symbol Height, and Minimum Symbol Quality**

See Section 5.5, Figure 5.5.2.7 - 2, GS1 System Symbol Specification Table 1.

**Symbol Placement**

Not Applicable

**Unique Application Processing Requirements**

Not Applicable

## 2.1.8. Identification of Variable Measure Trade Items – Restricted Circulation

### Application Description

Restricted circulation Variable Measure Trade Items are those sold in random quantity against a fixed price per unit quantity and intended to cross a Point-of-Sale (e.g., apples sold at a fixed price per kilogram).

These items are either marked in the store by the retailer or are marked at the source by the supplier. National solutions are available for this purpose.

GS1 Member Organisations should assign one or several of the GS1 Prefixes 02, 20 through 29 for the identification of Variable Measure Trade Items in their territory. GS1 Member Organisations should make part of this capacity available to user companies for company internal applications.

The data fields available after the relevant GS1 Prefix (defined by the GS1 Member Organisation for their territory) can be structured in a variety of ways to represent the product type, net weight, calculated price, or number of units. Equipment is commercially available for automatically weighing items, calculating an item price from the unit price, and printing the information as a bar code label. The scanning equipment and applications can then be programmed to use the prefix as an instruction to decode the ensuing data fields according to the particular structure adopted.

The first row in Figure 2.1.8 - 1 shows the structure specified by GS1 US for North America. The same structure is used by many other GS1 Member Organisations. The next two rows do not show predetermined structures. Examples of recommended structures are given in Figure 2.1.8 - 2. GS1 Member Organisations choose appropriate structures for use within their geographic area.

**Figure 2.1.8 - 1 Format of the Element String**

GS1 Prefix	Item Reference	Price Verifier-Digit	Item Price	Check Digit
0 2	N3 N4 N5 N6 N7	N8	N9 N10 N11 N12	N13
0 2	N3 N4 N5 N6 N7 N8 N9	N10 N11 N12		N13
2 N2	N3 N4 N5 N6 N7 N8 N9	N10 N11 N12		N13

The Item Reference is usually assigned by the company that scans the Element String at its Point-of-Sale. However, some countries may specify their own standard numbering systems for variable measure products administered by their GS1 Member Organisation or by a trade association.

The Price verifier-digit is the result of a special calculation, and its verification ensures correct reading of the price. For details, see Section 7.10.2 Security of reading this Element String without a Price verifier-digit depends on the Element String's Check Digit (see Section 7.10).

The item price is the price of the trade item in the relevant currency with an implied decimal point defined by the trading partners or the relevant GS1 Member Organisation. A different format is required for each position of the implied decimal point. Multiple formats require an unambiguous way to differentiate each format, and separate GS1 Prefixes may be assigned to accomplish this.

The Check Digit is explained in Section 7.10. Its verification, carried out automatically by the bar code reader, ensures that the data corresponds with the verification rules.

**Figure 2.1.8 - 2**

Examples of Alternative Data Structures		
Item Reference	Price verifier-digit	Item price
Item Reference		Item price
Item Reference	Measure verifier-digit	Item measure
Item Reference		Item measure

When the price (or weight) of an item is encoded using this Element String, a Price verifier-digit or a Measure verifier-digit should be used. The Measure verifier-digit is calculated from the digits in the item measure field in the same way that the Price verifier-digit is calculated from the item price digits (see Section 7).

The item measure is a measurement of the trade item with a defined unit of measure and an implied decimal point position. The unit of measure and decimal point position are defined within the relevant geographic area for each GS1 Prefix and/or format code. The item measure may be weight only if local weights and measures regulations permit.

The data transmitted from the bar code reader means that data about a Variable Measure Trade Item has been captured. The bar code reader normally performs the Price verifier-digit and the Measure verifier-digit calculation. Failing this, the calculation must take place in the application software.

Although each GS1 Member Organisation and/or user is free to develop a solution for numbering Variable Measure Trade Items, the GS1 System provides recommended structures that provide a degree of equipment standardisation. These formats may include an Item Reference, the retail price of the item, and a Price check-digit. The recommended structures are shown in Figure 2.1.8 - 3.

**Figure 2.1.8 - 3**

GS1 Prefix	Recommended Data Structures (Exact Structure Determined by GS1 Member Organisation)	Check Digit
0 2	I I I I I V P P P P	C
or	I I I I V P P P P P	C
2 0 - 29	I I I I I I P P P P	C
	I I I I I P P P P P	C

The GS1 Prefix is administered by each GS1 Member Organisation and denotes the format and meaning of a particular Element String, where:

- **I..I** = Item Reference
- **V** = Price check-digit calculated according to the algorithm specified in Section 7
- **P..P** = Price in local currency
- **C** = Check Digit calculated according to the standard algorithm in Section 7.10

**Note:** The price field may contain zero, one, or two implied decimal places depending on the monetary unit used. The decimal point, which is not included in the bar code symbol, must nevertheless be taken into account by the marking equipment when printing the Human Readable Interpretation on the label.

GS1 Member Organisations may choose to implement a national solution for Variable Measure Trade Items branded by the supplier for retail. Any national branded variable measure solution requires GS1 Member Organisations to manage the allocation of the item number at a national level.

### **GS1 Key**

#### **Definition**

Not Applicable

#### **Rules**

Not Applicable

#### **Attributes**

##### **Required**

Not Applicable

##### **Optional**

Not Applicable

#### **Rules**

Not Applicable

### **Data Carrier Specification**

#### **Carrier Choices**

The data carriers for this Element String are: UPC-A Bar Code Symbols and EAN-13 Bar Code Symbols.

The system recognises this Element String by the symbology identifier **JE0**, the GS1 Prefix 02 or 20 to 29, and the structure defined by the GS1 Member Organisation in which it is operating.

#### **Symbol X-Dimensions, Minimum Symbol Height, and Minimum Symbol Quality**

See Section 5.5, Figure 5.5.2.7 – 2, GS1 System Symbol Specification Table 1.

#### **Symbol Placement**

Not Applicable

### **Unique Application Processing Requirements**

Not Applicable

## **2.2. Numbering and Marking of Logistic Units**

A logistic unit is an item of any composition established for transport and/or storage that needs to be managed through the supply chain.

Tracking and tracing logistic units in the supply chain is a major application of the GS1 System. Scanning the standard identification number, marked on each logistic unit, allows the physical movement of units to be individually tracked and traced by providing a link between the physical movement of items and the associated information flow. It also opens up the opportunity to implement a wide range of applications, such as cross docking, shipment routing, and automated receiving.

Logistic units are identified with a GS1 identification number called the SSCC (Serial Shipping Container Code). The SSCC ensures that logistic units are identified with a number that is unique worldwide.

Attribute information, such as a consignment number, AI (401), may be optionally encoded using internationally agreed data structures and a bar code symbology that allow unambiguous interpretation.

## 2.2.1. Individual Logistic Units

### Application Description

A logistic unit is an item of any composition established for transport and/or storage that needs to be managed through the supply chain. The identification and symbol marking of logistic units enables a large number of user applications. In particular, the SSCC (Serial Shipping Container Code) provides a link between the physical logistic unit and information pertaining to the logistic unit that is communicated between trading partners using Electronic Data Interchange (EDI).

The SSCC Element String AI (00) is used for the identification of logistic units (see Section 3). Each individual logistic unit is allocated a unique number, which remains the same for the life of the logistic unit. When assigning an SSCC, the rule is that an individual SSCC number must not be reallocated within one year of the shipment date from the SSCC assignor to a trading partner. However, prevailing regulatory or industry organisation specific requirements may extend this period.

In principle, the SSCC provides a unique reference number that can be used as the key to access information regarding the logistic unit in computer files. However, attributes relating to the logistic unit (e.g., ship to information, logistic weights) are also available as standardised Element Strings.

### GS1 Key

#### Definition

The SSCC is the GS1 Identification Key used to identify logistics units. The key is comprised of and Extension Digit, the GS1 Company Prefix, Serial Reference, and Check Digit. Refer to Section 3 for details of the SSCC and associated data elements.

#### Rules

All SSCC Rules described in Section 4.

### Attributes

#### Required

Identification of a Logistic Unit: AI (00) (See Section 3.2 for List of all GS1 Application Identifier), if Fixed Measure AI (02) or Routing Code AI (403) are used when:

- a logistic unit is a grouping of trade items, it is sometimes useful to indicate the Global Trade Item Number (GTIN) of the contained items in association with the SSCC. See Section 3.2 for List of all GS1 Application Identifier, Identification of Trade Items Contained in a Logistic Unit - Fixed Measure: AI (02) and Count of Trade Items Contained in a Logistic Unit: AI (37).
- the routing code, AI (403), is assigned by a parcel carrier. It is intended to provide a migration path to the adoption of a yet to be defined international, multi-modal solution. See Section 3.2 for List of all GS1 Application Identifier, Routing Code: AI (403).

#### Optional

The use of attribute information on logistic units is optional. However, when used, attribute information should be processed with the SSCC that identifies the logistic unit.

- The Element String Ship to - Deliver to Global Location Number: AI (410) has been designed to allow the automatic sortation of logistic units using the Global Location Number (GLN). See Section 3.2 for List of all GS1 Application Identifier.
- The Element String Ship for - Deliver for - Forward to Global Location Number: AI (413), has been designed to allow the cross docking of logistic units using the Global Location Number

(GLN). It is used in conjunction with the Element String AI (410) to indicate the cross docking station and the final destination of the logistic unit. See Section 3.2 for List of all GS1 Application Identifier.

- The Element String Ship to - Deliver to Postal Code Within a Single Postal Authority: AI (420) has been designed to allow the automatic sortation of logistic units using the postal code in a single postal area. See Section 3.2 for List of all GS1 Application Identifier.
- The Element String Ship to - Deliver to Postal Code with Three-Digit ISO Country Code: AI (421) has been designed to allow the automatic sortation of logistic units using the postal code. As the postal code is prefixed by the ISO country code, it may be used internationally. See Section 3.2 for List of all GS1 Application Identifier.

### **Rules**

Refer to Section 4 for the mandatory associations.

### **Data Carrier Specification**

#### **Carrier Choices**

The only data carrier used to represent GS1 System individual logistic units is the GS1-128 Bar Code Symbology.

#### **Symbol X-Dimensions, Minimum Symbol Height, and Minimum Symbol Quality**

See Section 5.5, Figure 5.5.2.7 - 3, GS1 System Symbol Specification Table 2, and Figure 5.5.2.7 - 7, GS1 System Symbol Specification Table 6.

#### **Symbol Placement**

All the Symbol Placement Guidelines defined in Section 6.

### **Unique Application Processing Requirements**

For a description of processing requirements, see Section 7.

## **2.2.2. Multiple Logistic Units – Consignment Number**

### **Application Description**

Shipments and consignments can comprise one or many logistic units. If the shipment/consignment comprises more than one physical object there is no requirement that they are attached together. A consignment/shipment number identifies a logical grouping. When a shipment or consignment number is read the message is that this physical unit should be associated with any other physical units carrying the same shipment or consignment number. Individual physical units carry the SSCC as described in the previous section.

### **GS1 Key**

#### **Definition**

The consignment number, AI (401), identifies a logical grouping of goods (one or more physical entities) that has been consigned to a freight forwarder and is intended to be transported as a whole.

Refer to Section 3.2 for List of all GS1 Application Identifier for detailed information.

#### **Rules**

The data transmitted means that the Element String denoting a consignment number has been captured. The consignment number may be processed as stand-alone information where applicable or with other identification data appearing on the same unit.

**Attributes****Required**

Not Applicable

**Optional**

Not Applicable

**Rules**

Not Applicable

**Data Carrier Specification****Carrier Choices**

The data carrier used to represent the GS1 Consignment Number is the GS1-128 Bar Code Symbology.

**Symbol X-Dimensions, Minimum Symbol Height, and Minimum Symbol Quality**

See Section 5.5, Figure 5.5.2.7 - 3, GS1 System Symbol Specification Table 2, and Figure 5.5.2.7 - 7, GS1 System Symbol Specification Table 6.

**Symbol Placement**

All the Symbol Placement Guidelines defined in Section 6.

**Unique Application Processing Requirements**

For a description of processing requirements, see Section 7.

**2.2.3. Multiple Logistic Units – Shipment Number****Application Description**

- Shipments and consignments can comprise one or many logistic units. If the shipment/consignment comprises more than one physical object there is no requirement that they are attached together. A consignment/shipment number identifies a logical grouping. When a shipment or consignment number is read the message is that this physical unit should be associated with any other physical units carrying the same shipment or consignment number. Individual physical units carry the SSCC as described in the previous section.
- The shipment number (bill of lading) is assigned by a consignor. It is a globally unique number that identifies a logical grouping of physical units in a transport shipment. It may be used as a communication reference by all parties in the transport chain, such as in Electronic Data Interchange (EDI) messages where it can be used as a shipment reference and/or a consignor's loading list. See Section 3.2 for List of all GS1 Application Identifier, Shipment Number: AI (402).

**GS1 Key****Definition**

The shipment identification number (bill of lading) is a number assigned by a consignor. It provides a globally unique number that identifies a logical grouping of physical units for the purpose of a transport shipment

**Rules**

The data transmitted means that the Element String denoting a shipment identification number has been captured. The shipment identification number may be processed as stand-alone information where applicable or with other identification data appearing on the same unit.

**Attributes****Required**

Not Applicable

**Optional**

Not Applicable

**Rules**

Not Applicable

**Data Carrier Specification****Carrier Choices**

The data carrier used to represent GS1 System individual logistic unit is the GS1-128 Bar Code Symbology.

**Symbol X-Dimensions, Minimum Symbol Height, and Minimum Symbol Quality**

See Section 5.5, Figure 5.5.2.7 - 3, GS1 System Symbol Specification Table 2, and Figure 5.5.2.7 - 7, GS1 System Symbol Specification Table 6.

**Symbol Placement**

All the Symbol Placement Guidelines defined in Section 6.

**Unique Application Processing Requirements**

For a description of processing requirements, see Section 7.

## 2.3. Assets

The GS1 System provides a method for the identification of assets. The object of asset identification is to identify a physical entity as an inventory item.

Each company holding a GS1 Company Prefix may assign asset identifiers to the assets or trade items supplied to their customers. Best practices may dictate that the trade item manufacturer apply the asset identifier during the manufacturing process. This number may then be used for ordering new assets of an identical type. The GS1 System asset identifiers act as keys to access the characteristics of an asset stored in a computer file and/or to record movements of assets.

Asset identifiers may be used for simple applications, such as the location and usership of a given fixed asset (e.g., a personal computer) or for complex applications, such as recording the characteristics of a returnable asset (e.g., a reusable beer keg), its movements, its life-cycle history, and any relevant data for accounting purposes.

### 2.3.1. Global Returnable Asset Identifier (GRAI): AI (8003)

**Application Description**

A Returnable Asset is a reusable package or transport equipment of a certain value, such as a beer keg, a gas cylinder, a plastic pallet, or a crate. The GS1 System identification of a Returnable Asset,

the Global Returnable Asset Identifier (GRAI), enables tracking as well as recording of all relevant data.

The Element String comprises the GRAI (see Section 3.2 for List of GS1 Application Identifier). The GRAI is composed of the GS1 Company Prefix of the company assigning the asset identifier and of the Asset Type. The latter is assigned to uniquely identify, together with the GS1 Company Prefix, a particular kind of asset. The GRAI remains the same for all identical Returnable Assets. Although consecutive numbering is recommended, the structure is left to the discretion of the assigning company. An optional serial number may be used to distinguish Individual Assets within a given asset type.

A typical application using this Element String is in tracking returnable beer kegs. The owner of the beer keg applies a bar code symbol carrying a GRAI to the keg using a permanent marking technique. This bar code symbol is scanned whenever the keg is supplied full to a customer and scanned again when it is returned. This scanning operation allows the beer keg owner to automatically capture the life-cycle history of a given keg and to operate a deposit system, if desired.



**Note:** This Element String identifies a physical entity as a Returnable Asset. When such a physical entity is used to transport or to contain a trade item, the Element String AI (8003) must never be used to identify the transported or contained trade item.

## GS1 Key

### **Definition**

The GS1 Identification Key used to identify Returnable Assets. The key is comprised of a GS1 Company Prefix, Asset Type, Check Digit, and optional serial number.

The structure of the Element String for a Global Returnable Asset Identifier (GRAI) can include two parts: the mandatory Asset Type Identification and an optional serial number (see Section 3.2 for List of GS1 Application Identifier).

### **Rules**

See Section 4, Application Rules.

### **Attributes**

The attributes of the asset should be established on a computer file using the GS1 System asset identifier as the key to the information. Examples of the type of information held include the full name and address of the party who owns the asset, the value of the asset, the location of the asset, and the life-cycle history of the asset.

### **Required**

Not Applicable.

### **Optional**

The owner of the asset assigns the optional serial number. It denotes an Individual Asset within a given Asset Type. The field is alphanumeric and is used to distinguish Individual Assets with the same Asset Types.

See Section 3.2 for List of all GS1 Application Identifier, Global Returnable Asset Identifier (GRAI): AI (8003).

### **Rules**

See Section 4, Application Rules (none is currently identified).

## Data Carrier Specification

### **Carrier Choices**

The only data carrier used to represent GS1 System asset identifiers is the GS1-128 Bar Code Symbology. When encoding an asset identifier, GS1-128.

### **Symbol X-Dimension, Minimum Symbol Height, and Minimum Symbol Quality**

See Section 5.5, Figure 5.5.2.7 – 3, GS1 System Symbol Specification Table 2.

### **Symbol Placement**

Not Applicable.

## Unique Application Processing Requirements

For a description of processing requirements, see Section 7.

## 2.3.2. Global Individual Asset Identifier (GIAI): AI (8004)

### Application Description

In the GS1 System, an Individual Asset is considered a physical entity made up of any characteristics.

This Element String identifies a particular physical entity as an asset. It must not be used for other purposes and must be unique for a period well beyond the lifetime of the relevant asset records. Whether or not the assigned Global Individual Asset Identifier (GIAI) may remain with the physical item when changing hands depends on the particular business application. If it remains with the physical item, then it must never be re-used.

The GIAI comprises the GS1 Company Prefix of the company assigning the asset identifier and an Individual Asset Reference (see Section 3). The Individual Asset Reference is alphanumeric. Its structure is left to the discretion of the company applying the Element String.

This Element String might, for example, be used to record the life-cycle history of aircraft parts. By symbol marking the GIAI, AI (8004), on a given part, aircraft operators are able to automatically update their inventory database and track assets from acquisition until retirement.

### GS1 Key

#### **Definition**

The GS1 Identification Key used to identify an Individual Asset. The key is comprised of a GS1 Company Prefix and an Individual Asset Reference (see Section 3.2 for List of all GS1 Application Identifier).

#### **Rules**

See Section 4, Application Rules.

#### **Attributes**

The attributes of the asset should be established on a computer file using the GS1 System asset identifier as the key to the information. Examples of the type of information held include the full name and address of the party who owns the asset, the value of the asset, the location of the asset, and the life-cycle history of the asset.

#### **Required**

None is currently standardized.

**Optional**

None is currently standardized.

**Rules**

See Section 4, Application Rules (none is currently identified).

**Data Carrier Specification****Carrier Choices**

The only data carrier used to represent GS1 System asset identifiers is the GS1-128 Bar Code Symbology.

**Symbol X-Dimension, Minimum Symbol Height, and Minimum Symbol Quality**

See Section 5.5, Figure 5.5.2.7 – 3, GS1 System Symbol Specification Table 2.

**Symbol Placement**

Not Applicable

**Unique Application Processing Requirements**

For a description of processing requirements, see Section 7.

## 2.4. Locations

### 2.4.1. Introduction

A Global Location Number (GLN) is used to identify any location (physical or legal) that needs to be uniquely identified for use in the supply chain.

The GLN makes possible the unique and unambiguous identification of physical locations and legal entities used in the supply chain. Identification in this manner is a prerequisite to efficient Electronic Commerce between trading partners (e.g., Electronic Data Interchange (EDI), electronic catalogues). The GTIN-13 Data Structure is used for the GLN. Note that when a U.P.C. Prefix is used to generate the GLN, the U.P.C. Prefix should be considered as having a leading zero (see Section 1.3.3 for a full definition of the GS1 Company Prefix).

Within the GS1 System, the GLN and the Global Trade Item Number (GTIN) are two distinct data identifiers. There is no conflict when a GTIN and a GLN have the same digits, because the data carrier (EDI, machine readable symbol, or radio frequency) will distinguish between the two identifiers. For example, when GLNs are used in Automatic Identification and Data Capture (AIDC) and EDI, the context (Application Identifiers and qualifiers) will prevent any misinterpretation. Each company or organisation that is a member of a GS1 Member Organisation may use GLNs to identify locations under the terms of its membership. For full contact details of the GS1 Member Organisations worldwide, visit [www.gs1.org](http://www.gs1.org).

Although in some countries the national GLN database is administered by the GS1 Member Organisation, it remains the responsibility of the company issuing the numbers to keep business partners informed of all relevant GLNs related to the trading relationship. Special care is needed if ownership of the company changes (see Section 1.7.1).

In business operations, location numbers are of no value if they are not associated with business attributes. All Element Strings described in this section indicate the particular usage of the GLN represented in the bar code symbol.

The GLN is designed to improve the efficiency of communication with trading partners and add value to the trading partners involved as well as to consumers. GLNs can identify:

- **Physical locations** – A single point of access with a physical address, such as a particular room in a building, warehouse, warehouse gate, loading dock, delivery point, cabinet, cabinet shelf, or a room within a building, as well as operational locations such as EDI mailboxes
- **Legal entities** – The legal organisation that is subscribed to the GS1 System, such as whole companies or subsidiaries, including suppliers, customers, financial services companies, and freight forwarders

Each GLN points to a unique record that has distinctions created by fields of data that answer three questions: who, what and where. The “who” is the organisation controlling or owning the GLN. The “what” qualifies or states the context of the relationship of the associated data. The “where” is the physical address of the location.

## 2.4.2. EDI and Global Data Synchronization (GDS)

Electronic Data Interchange (EDI) ideally uses Global Location Numbers (GLNs) to identify all trading partners and locations involved. The mailbox or network address for companies has traditionally been identified with a GLN to support EDI applications. The EDI standards promoted by the GS1 System (EANCOM, GS1 Business Messaging Standards (XML)) make full use of GLNs to simplify the automation of business messaging. Any GLN related Application Identifier should have an equivalent field (data element) in EDI messages.

GLNs and associated information of trading partners are communicated at the start of the relation through the party information message (PARTIN). GLNs are then used during the trading relationship in any other business message, such as invoice, order, pay, or deliver.

National data pools and the global registry that links them for the purpose of global data synchronisation mandate the use of GLNs to identify each party that provides information to any data pool or who requires information about products and locations.

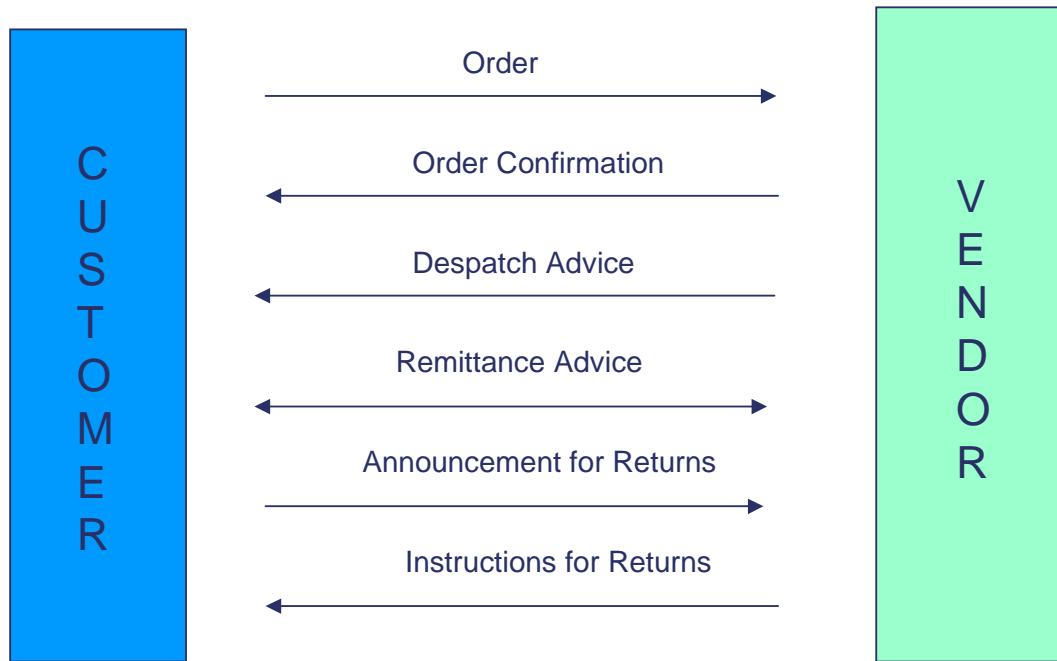
- ✔ **Note:** The GS1 General Specifications do not provide details on business messages or the Global Data Synchronisation Network (GDSN). For further information, please consult the relevant GS1 standard.

## 2.4.3. Application Overview

### 2.4.3.1. Identification of a Legal Entity

Legal entities require identification within electronic business networks (e.g., Electronic Data Interchange (EDI) networks, electronic catalogues). The use of Global Location Numbers (GLNs) in these areas is driven by the exact party role within a given business process requirement. The GLN can be used as a GS1 Identification Key to access master data associated with a given business transaction.

**Figure 2.4.3.1 - 1 High-Level Example of a Trading Partner Scenario**



The use of a GLN as a unique key to master data in transactional messages makes such applications more efficient and provides greater accuracy of data. In EANCOM, a GLN is mandatory in the header of any message. Using GLNs for such business processes requires an appropriate qualifier.

#### 2.4.4. Global Location Number to Identify a Physical Location: AI (414)

##### Application Description

An Element String with an Application Identifier (AI) (414) identifies a physical location. This implies that this Element String is represented in a data carrier on the location itself. Physical locations may, for example, be a room, a door of a warehouse, an x-ray room in a hospital, or a control point.

This Element String may be used to record and confirm presence at a given location for any purpose. An equivalent field will hold this information in Electronic Messages.

A typical application using this Element String is the identification of a warehouse dock as a delivery point. The driver is directed to a given warehouse dock and the Global Location Number (GLN) identifying the warehouse dock, and the Global Trade Item Number (GTIN) or SSCC (Serial Shipping Container Code) identifying the goods are scanned whenever a delivery is made to the location. The Electronic Message from the scanner is then used to automatically update the warehouse's stock management system of the delivery.

##### GS1 Key

##### Definition

The Global Location Number (GLN) is the GS1 Identification Key used to identify physical locations or legal entities. The key is comprised of a GS1 Company Prefix, Location Reference, and Check Digit.

##### Rules

All the GLN Allocation Rules described in Section 4.

## Attributes

### **Required**

See Section 3.2 for List of all GS1 Application Identifier, Identification of a Physical Location - Global Location Number: AI (414).

### **Optional**

The use of GLN Extension is restricted for internal purposes. For communication between trading partners, a GLN should be used following the rules defined in Section 4. The GLN extension will not be communicated to trading partners except by mutual agreement.

The ability to provide GLN extensions is expected to be an important business requirement with the EPC network. Locations that currently have a GLN may also use an optional GLN extension component to distinguish unique locations (e.g., storage slots, door locations, bin storage, shelves, peg holes, rack, cabinet, computer/communication bays). However, a company may choose to assign a unique GLN, without an extension component, as a way to identify these locations.

The extension component is used to identify internal physical locations within a location previously identified with a GLN (e.g., stores, factories, buildings).

The GLN plus extension component must not be used to identify more than one site.

With experience using the EPC network, it is likely that additional rules will be defined. Extension Application Identifier (254) is a variable length alphanumeric field up to 20 characters in length. Implementation using EPC generation 1 tags will limit the extension to a maximum of 12 numeric digits. A/N functionality will be resolved during Generation 2 development.

For more information, see Section 3.2 for List of all GS1 Application Identifier, GLN Extension Component: AI (254).

### **Rules**

See Section 4, Mandatory Association of Element Strings.

## Data Carrier Specification

### **Carrier Choices**

The Global Location Number (GLN) is used to identify a physical location and, when required, may be carried by a bar code symbol using the appropriate Application Identifier. The data carrier used to represent the GLN is the GS1-128 Bar Code Symbology.

### **Symbol X-Dimension, Minimum Symbol Height, and Minimum Symbol Quality**

When encoding the Global Location Number (GLN), GS1-128 Bar Code Symbols should be printed at an X-dimension between 0.25 mm (0.00984 in.) and 1.016 mm (0.040 in.). However, if the GLN is carried by a bar code symbol on a GS1 logistic label, the recommendations contained in Section [2.2](#) apply.

### **Symbol Placement**

Not Applicable

## Unique Application Processing Requirements

For a description of processing requirements, see Section 7.

## 2.4.5. Ship to – Deliver to Global Location Number: AI (410)

### Application Description

An Element String with an Application Identifier (AI) (410) represents the Global Location Number (GLN) of the recipient of a logistic unit. The GLN refers to the address where a particular consignment is to be delivered. This Element String is used in single leg transport operations. A logistic unit may include a bar code symbol carrying the GLN of the unit's intended destination. When scanning this Element String, the data transmitted may be used to retrieve the related address and/or to sort the item by destination.

### GS1 Key

#### Definition

The Global Location Number (GLN) is the GS1 Identification Key used to identify physical locations or legal entities. The key is comprised of a GS1 Company Prefix, Location Reference, and Check Digit.

#### Rules

All the GLN Allocation Rules described in Section 4.

### Attributes

#### Required

See Section 3.2 for List of all GS1 Application Identifier, Ship to - Deliver to Global Location Number: AI (410).

#### Optional

Not Applicable

#### Rules

Not Applicable

### Data Carrier Specification

#### Carrier Choices

The data carrier used to represent the Global Location Number (GLN) is the GS1-128 Bar Code Symbology.

#### **Symbol X-Dimension, Minimum Symbol Height, and Minimum Symbol Quality**

When encoding the Global Location Number (GLN), GS1-128 Bar Code Symbols should be printed at an X-dimension between 0.25 mm (0.00984 in.) and 1.016 mm (0.040 in.). However, if the GLN is carried by a bar code symbol on a GS1 logistics label, the recommendations contained in Section [2.2](#) apply.

#### **Symbol Placement**

Not Applicable

### Unique Application Processing Requirements

For a description of processing requirements, see Section 7.

## 2.4.6. Bill to - Invoice to Global Location Number: AI (411)

### Application Description

An Element String with Application Identifier (AI) (411) represents the Global Location Number (GLN) of the addressee of an invoice. The GLN refers to the name and address of the business partner to which an entity shall be invoiced and includes accounting-related information that may be used wherever required.

### GS1 Key

#### Definition

The Global Location Number (GLN) is the GS1 Identification Key used to identify physical locations or legal entities. The key is comprised of a GS1 Company Prefix, Location Reference, and Check Digit.

#### Rules

All the GLN Allocation Rules described in Section 4.

### Attributes

#### Required

See Section 3.2 for List of all GS1 Application Identifier, Bill to - Invoice to Global Location Number: AI (411).

#### Optional

Not Applicable

#### Rules

See Section 4.

### Data Carrier Specification

#### Carrier Choices

The data carrier used to represent the Global Location Number (GLN) is the GS1-128 Bar Code Symbology.

#### *Symbol X-Dimension, Minimum Symbol Height, and Minimum Symbol Quality*

When encoding the Global Location Number (GLN), GS1-128 Bar Code Symbols should be printed at an X-dimension between 0.25 mm (0.00984 in) and 1.016 mm (0.040 in). However, if the GLN is carried by a bar code symbol on a GS1 logistic label, the recommendations contained in Section [2.2](#) apply.

#### *Symbol Placement*

Not Applicable

### Unique Application Processing Requirements

For description of processing requirements, see Section 7.

## 2.4.7. Purchased from Global Location Number: AI (412)

### Application Description

In business it is sometimes important to know from where a particular item was purchased. Applied on a trade item, an Element String with Application Identifier (AI) (412) provides the Global Location Number (GLN) of the company from which the respective trade item has been purchased. Attributes

## GS1 Key

### **Definition**

The Global Location Number (GLN) is the GS1 Identification Key used to identify physical locations or legal entities. The key is comprised of a GS1 Company Prefix, Location Reference, and Check Digit.

### **Rules**

All the GLN Allocation Rules described in Section 4.

### **Attributes**

#### **Required**

See Section 3.2 for List of all GS1 Application Identifier, Purchased from Global Location Number: AI (412).

#### **Optional**

Not Applicable

### **Rules**

See Section 4.

## Data Carrier Specification

### **Carrier Choices**

The data carrier used to represent the Global Location Number (GLN) is the GS1-128 Bar Code Symbology.

#### **Symbol X-Dimension, Minimum Symbol Height, and Minimum Symbol Quality**

When encoding the Global Location Number (GLN), GS1-128 Bar Code Symbols should be printed at an X-dimension between 0.25 mm (0.00984 in.) and 1.016 mm (0.040 in.). However, if the GLN is carried by a bar code symbol on a GS1 logistic label, the recommendations contained in Section [2.2](#) apply.

#### **Symbol Placement**

Not Applicable

## Unique Application Processing Requirements

For description of processing requirements, see Section 7.

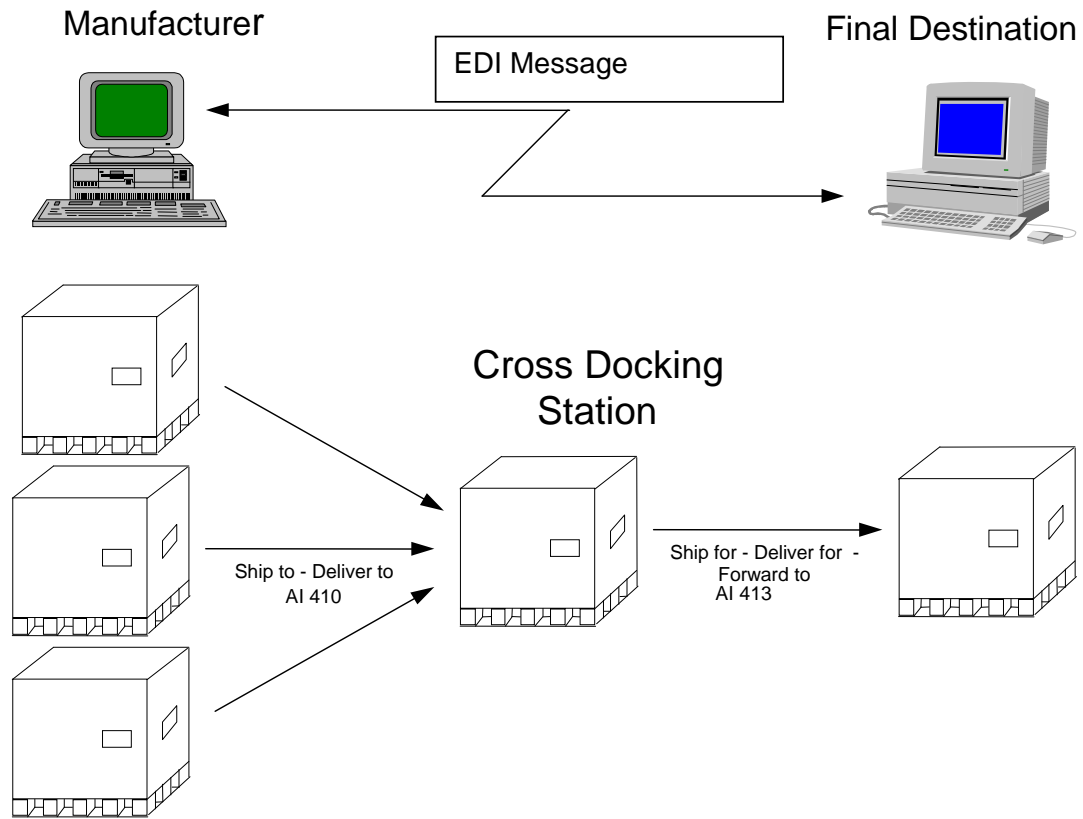
## 2.4.8. Ship for - Deliver for - Forward to Global Location Number: AI (413)

### **Application Description**

An Element String with Application Identifier (AI) (413) is used by the consignee for determining the internal or subsequent final destination of a physical unit.

Cross docking is a typical application using this Element String. Here, a bar code symbol carrying the Element String AI (410) is placed on a logistic unit at the point of creation to direct the goods to the intermediate destination (e.g., a distribution centre). The Element String AI (413) is also carried by the bar code symbol to direct the goods to their final destination (e.g., a retail store served by the distribution centre).

**Figure 2.4.8 - 1 Example of a Cross Docking Application**



**GS1 Key**

**Definition**

The Global Location Number (GLN) is the GS1 Identification Key used to identify physical locations or legal entities. The key is comprised of a GS1 Company Prefix, Location Reference, and Check Digit.

**Rules**

All the GLN Allocation Rules described in Section 4.

**Attributes**

**Required**

See Section 3.2 for List of all GS1 Application Identifier, Ship for - Deliver for - Forward to Global Location Number: AI (413).

**Optional**

Not Applicable

**Rules**

See Section 4.

**Data Carrier Specification**

**Carrier Choices**

The data carrier used to represent the Global Location Number (GLN) is the GS1-128 Bar Code Symbology.

**Symbol X-Dimension, Minimum Symbol Height, and Minimum Symbol Quality**

When encoding the Global Location Number (GLN), GS1-128 Bar Code Symbols should be printed at an X-dimension between 0.25 mm (0.00984 in.) and 1.016 mm (0.040 in.). However, if the GLN is carried by a bar code symbol on a GS1 logistics label, the recommendations contained in Section [2.2](#) apply.

**Symbol Placement**

Not Applicable

**Unique Application Processing Requirements**

For a description of processing requirements, see Section 7.

**2.4.9. Global Location Number of the Invoicing Party: AI (415)****Application Description**

An Element String with Application Identifier (AI) (415) is used to indicate the Global Location Number (GLN) of the invoicing party. The GLN is mandatory information for the payment slip application (see Section [2.6.10](#)).

**GS1 Key****Definition**

The Global Location Number (GLN) is the GS1 Identification Key used to identify physical locations or legal entities. The key is comprised of a GS1 Company Prefix, Location Reference, and Check Digit.

**Rules**

All the GLN Allocation Rules described in Section 4.

**Attributes****Required**

See Section 3.2 for List of all GS1 Application Identifier, Global Location Number of the Invoicing Party: AI (415).

**Optional**

Not Applicable

**Rules**

See Section 4, Mandatory Association of Element Strings.

**Data Carrier Specification****Carrier Choices**

The data carrier used to represent the Global Location Number (GLN) is the GS1-128 Bar Code Symbology.

**Symbol X-Dimension, Minimum Symbol Height, and Minimum Symbol Quality**

When encoding the Global Location Number (GLN), GS1-128 Bar Code Symbols should be printed at an X-dimension between 0.25 mm (0.00984 in.) and 1.016 mm (0.040 in.). However, if the GLN is carried by a bar code symbol on a GS1 logistics label, the recommendations contained in Section [2.2](#) apply.

**Symbol Placement**

Not Applicable

**Unique Application Processing Requirements**

For a description of processing requirements, see Section 7.

## 2.5. Numbering and Symbol Marking of Service Relationships

**Application Description**

The Global Service Relation Number (GSRN) is used to identify the recipient of services in the context of a service relationship. It provides a unique and unambiguous identification number for the service provider to store data relevant to service(s) provided to the recipient. The GSRN is the key to access information stored on computer systems or reference information transferred via Electronic Data Interchange (EDI).

The GSRN can be used to identify the service relationships in:

- A hospital admission, where it could be used to record a patient's room charges, medical tests, and patient charges
- A membership in a frequent flyer programme, where it could be used to record awards, claims, and preferences
- A membership in a loyalty scheme, where it could be used to record visits, purchase value, and awards
- A membership in a club, where it could be used for recording entitlements, use of facilities, and subscriptions
- A service agreement, where it could be used to manage agreed upon services, such as maintenance services for a television or computer

The GSRN is a non-significant number used to identify a database entry for recording recurring services. These services are activities carried out by a service provider for a service user, based upon a bilateral agreement. Consequently, the GSRN identifies a particular service arrangement with reference to a particular service provider and to a particular user. It may in some instances identify the user as a participant (or member) in a programme or scheme. However, it never constitutes a person's personal identification number because it is always related to a given service arrangement.

**GS1 Key****Definition**

The Global Service Relation Number is the GS1 Identification Key used to identify the relationship between a service provider and service recipient. See Section 3.2 for List of all GS1 Application Identifier, AI (8018), for more details.

**Rules**

See Section 4, GSRN Allocation Rules.

**Attributes****Required**

Not Applicable

**Optional**

Not Applicable.

**Rules**

Not Applicable

**Data Carrier Specification**

**Carrier Choices**

The data carrier for the Global Service Relation Number (GSRN) is the GS1-128.

**Symbol X-Dimension, Minimum Symbol Height, and Minimum Symbol Quality**

See Section 5.5, Figure 5.5.2.7 – 5, GS1 System Symbol Specification Table 4.

**Symbol Placement**

No standard placement is required. The following are some examples for the usage of GSRN.

A typical application using this Element String is the identification of membership in a student library. The library would issue all members a card that includes a unique GSRN identifying the relationship between the library and a student. The library would then scan the GSRN whenever a book was lent or returned. The Electronic Message from the scanner would then be used to automatically update the library's stock management database. See Figure 2.5 – 1 for an example of how the GSRN would appear on this membership card.

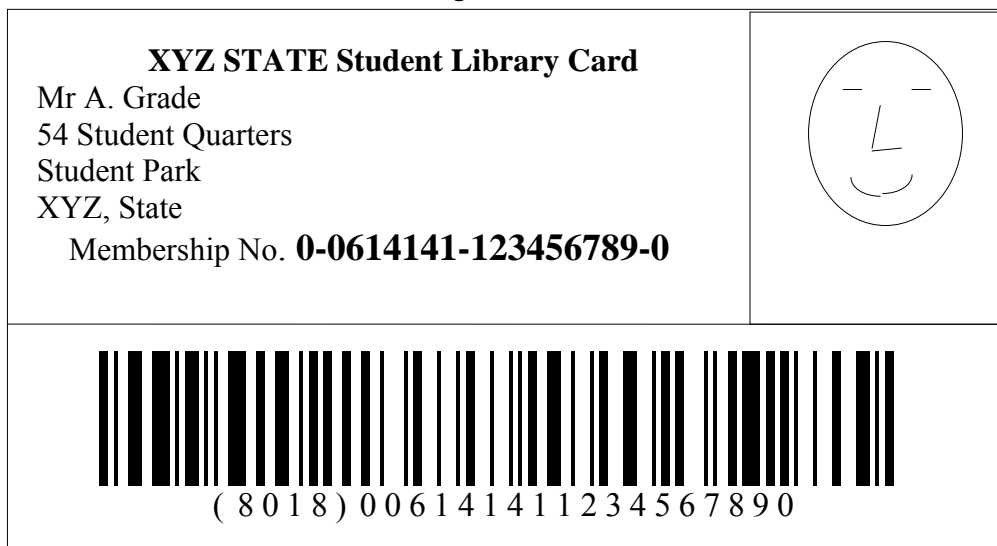
The worldwide, unique GSRN may also be used in other applications. For example, it could be used to give students access to other libraries that have formed a cooperative lending agreement.

GSRNs also can be used to identify hospital patients. In this case, the service provider is the hospital and the service recipient is the patient. The GS1 Company Prefix used is the one allocated to the hospital. The hospital generates a GSRN for each of its patients and encodes it in a GS1-128 Bar Code Symbol on the patient's wristband as well as his or her corresponding medical record.

When a product or service is administered (e.g., a particular treatment is given) it can easily be associated with the patient by scanning the patient's GSRN and the Global Trade Item Number (GTIN) of the product or service.

It should be noted that the GSRN is not meant to identify a single service as a trade item. Neither is it used to identify a physical unit as a trade item. It may identify a physical unit for service purposes (e.g., a computer with a service agreement).

**Figure 2.5 - 1**



## Unique Application Processing Requirements

For a description of processing requirements, see Section 7.

## 2.6. Numbering and Symbol Marking for Special Applications

### 2.6.1. Coupons

A coupon is a voucher that can be redeemed at the Point-of-Sale for a cash value or free item. Coupon identification is organised at the local level. Determining the data structure of a coupon is, therefore, the responsibility of the GS1 Member Organisations for their area of jurisdiction.

The purpose of coupon numbering and symbol marking is to automate and speed up coupon handling procedures at the Point-of-Sale. Moreover, coupon issuers and retailers may be able to reduce the costs involved in sorting coupons, administering manufacturers' payments, and producing reports on redemption.

All GS1 System coupon standards presented here allow for coupon validation (e.g., to check whether the item(s) covered by the coupon is within the customer's order).

If either validation or value look up is performed, manufacturers must advise their distributors and retailers of the impending issue of a coupon so that retailers' files can be updated to process the information at the Point-of-Sale.

A GS1 System coupon number is used for numbering promotional coupons for manufacturers and retailers as well as tokens with monetary value, such as gift tokens, book tokens, food stamps, record vouchers, luncheon vouchers, and social security tokens.

The structure of GS1 System coupon numbers ensures uniqueness against all other GS1 System numbers only when used within the monetary area of the appropriate GS1 Member Organisation(s).

### 2.6.2. Allocating GS1 System Coupon Data

#### 2.6.2.1. General Rule

GS1 System coupon identification specifications are flexible and have been designed to cater to current and future requirements.

Due to the nature of coupon numbering, a range of national solutions is offered, each of which is defined by the respective GS1 Member Organisation. National coupon solutions are not unique worldwide and must be operated in the restricted area defined by the GS1 Member Organisation.

In the interest of consistency and to avoid misinterpretation by equipment vendors, when defining national specifications, GS1 Member Organisations should include appropriate mention of all GS1 System coupon data structures.

Coupon reference numbers must not be re-used for a period of three years.

#### 2.6.2.2. Recommendation on Allocating Coupon Reference Numbers

The exact method used to allocate GS1 System coupon reference numbers is left to the discretion of the issuing organisation. However, the GS1 US Coupon Code must be unique for each individual promotion.

For ease of administration, coupon reference numbers should be allocated sequentially.

### 2.6.3. Coupon Identification for Restricted Geographic Distribution (GS1 Prefix 99)

#### Application Description

A coupon is a voucher with a cash value that is deducted at the Point-of-Sale. It is sometimes associated with a specific trade item. Coupon identification is organised on a national level and is therefore not unique worldwide. The specification of the coupon data structure in the Element String is the responsibility of each GS1 Member Organisation.

The internationally agreed standard for GS1 System coupon numbers is shown in Figure 2.6.3 - 1.

Figure 2.6.3 - 1

GS1 Prefix	Coupon Data (Structure Determined by GS1 Member Organisation)	Check Digit
9 9	N <sub>3</sub> N <sub>4</sub> N <sub>5</sub> N <sub>6</sub> N <sub>7</sub> N <sub>8</sub> N <sub>9</sub> N <sub>10</sub> N <sub>11</sub> N <sub>12</sub>	N <sub>13</sub>

The GS1 Prefix 99 denotes the Element String for GS1 coupon identification.

The structure of the coupon data field is determined according to the needs of a particular country. Mandatory components are the coupon issuer number and the coupon reference number. Other useful data are the redemption value in real or encoded format and codes for the decimal point or tax rates.

The Check Digit is explained in Section 7.10. Its verification, carried out automatically by the bar code reader, ensures that the data corresponds with the verification rules.

The data transmitted from the bar code reader means that the data of a coupon has been captured. Processing of coupons at a Point-of-Sale usually consists of validity checks and deduction of its value.

Within this agreed standard for GS1 System coupon numbers, each GS1 Member Organisation is free to develop a national coupon solution. Four recommended structures provide a degree of equipment standardisation. These recommended structures are shown in Figure 2.6.3 - 2.

Figure 2.6.3 - 2

GS1 Prefix	Recommended Coupon Data Structures (Exact Structure Determined by GS1 Member Organisation)	Check Digit
9 9	Y Y Y Y R R R V V V	C
9 9	Y Y Y R R R V V V V	C
9 9	Y Y Y Y Y R R R T T	C
9 9	Y Y Y Y Y R R R R R	C

- Where:
- Y** = Coupon issuer number (issued by the GS1 Member Organisation)
  - R** = Coupon reference number (allocated by a coupon issuer)
  - V** = Redemption value
  - T** = Value code (standardised by the GS1 Member Organisation)
  - C** = Check Digit calculated according to the standard algorithm

The GS1 Member Organisations or retailers may require that the third digit of the coupon numbers (990 to 999) be programmable in order to cope with specific demands such as:

- Taxable or non-taxable coupons
- Different currencies
- Indication of the decimal position

### **GS1 Key**

#### **Definition**

Not Applicable

#### **Rules**

Not Applicable

#### **Attributes**

##### **Required**

Not Applicable

##### **Optional**

Not Applicable

#### **Rules**

Not Applicable

### **Data Carrier Specification**

#### **Carrier Choices**

A coupon with the GS1 Prefix 99 is carried by the EAN-13 Bar Code Symbol.

The system recognises this Element String by the symbology identifier **JE0** and the GS1 Prefix.

#### **Symbol X-Dimension, Minimum Symbol Height, and Minimum Symbol Quality**

See Section 5.5, Figure 5.5.2.7 – 2, GS1 System Symbol Specification Table 1.

#### **Symbol Placement**

Not Applicable

### **Unique Application Processing Requirements**

For a description of processing requirements, see Section 7.

## **2.6.4. GS1 Common Currency Coupon Identification (GS1 Prefixes 981 and 982)**

A coupon is a voucher with a cash value that is deducted at the Point-of-Sale. It is sometimes associated with a specific trade item. Coupon identification is normally organised on a national level using the GS1 Prefix 99. However, for a common currency area, coupon identification is organised between participating countries. Determining the coupon data structure in the Element String is the responsibility of all the GS1 Member Organisations in the common currency area.

The GS1 Prefixes 981 and 982 have been released for use with coupons expressing a value in a common currency.

The structure of the coupon data positions is determined according to the needs of a particular set of countries. Mandatory components are the coupon issuer number and the coupon reference number. Further useful data is the redemption value in real or encoded format and numbers for the decimal point or tax rates.

The Check Digit is explained in Section 7.10. Its verification, carried out automatically by the bar code reader, ensures that the data corresponds with the verification rules.

The internationally agreed standard for GS1 Common Currency Coupon Codes is shown in Figure 2.6.4 - 1.

Figure 2.6.4 - 1

GS1 Prefix	Coupon Data (Structure Determined by GS1 MOs in Common Currency Area)	Check Digit
9 8 1 or 9 8 2	N <sub>4</sub> N <sub>5</sub> N <sub>6</sub> N <sub>7</sub> N <sub>8</sub> N <sub>9</sub> N <sub>10</sub> N <sub>11</sub> N <sub>12</sub>	N <sub>13</sub>

Within this structure, GS1 Member Organisations in a common currency area should develop a common coupon solution that is valid throughout the common currency area.

### 2.6.4.1. Use of GS1 Common Currency Coupon Code for the Euro

#### Application Description

At present the only application of GS1 Prefixes 981 and 982 is for the euro. The euro is a new currency that began to replace the national currencies of some countries on 1 January 1999.

Within the euro area, coupon issuer numbers are administered by:

GS1 BELGIUM • LUXEMBOURG  
 Rue Royale 29  
 1000 Brussels  
 Belgium  
 Tel: + 32.2.229.18.80  
 Fax: + 32.2.217.43.47  
 Web: [www.gs1belu.org](http://www.gs1belu.org)

See Figure 2.6.4.1 - 1 for the coupon data structure in the euro area.

Figure 2.6.4.1 - 1

GS1 Prefix	Coupon Data			Check Digit
9 8 1	Y <sub>1</sub> Y <sub>2</sub> Y <sub>3</sub> Y <sub>4</sub>	R <sub>1</sub> R <sub>2</sub>	E E , E	C
9 8 2	Y <sub>1</sub> Y <sub>2</sub> Y <sub>3</sub> Y <sub>4</sub>	R <sub>1</sub> R <sub>2</sub>	E , E E	C

Where:

- Y = Coupon issuer number (issued by a GS1 Member Organisation)
- R = Coupon reference number (allocated by a coupon issuer)
- E = Redemption value (expressed in euro); value 000 indicates free gift
- C = Check Digit calculated according to the standard algorithm

**Note:** The only difference between the two structures is the position of the implied decimal point.

#### GS1 Key

##### Definition

Not Applicable

**Rules**

Not Applicable

**Attributes**

**Required**

Not Applicable

**Optional**

Not Applicable

**Rules**

Not Applicable

**Data Carrier Specification**

**Carrier Choices**

A coupon with the GS1 Prefix 981 or 982 is carried by the EAN-13 Bar Code Symbol.

The system recognises this Element String by the symbology identifier **JE0** and the GS1 Prefix. The data transmitted from the bar code reader means that the data of a common currency coupon has been captured. Processing of coupons at a Point-of-Sale usually consists of validity checks and deduction of its value.

**Symbol X-Dimension, Minimum Symbol Height, and Minimum Symbol Quality**

See Section 5.5, Figure 5.5.2.7 – 2, GS1 System Symbol Specification Table 1.

**Symbol Placement**

Not Applicable

**Unique Application Processing Requirements**

For a description of processing requirements, see Section 7.

**2.6.5. GS1 US Coupon Code Identification for Use in North America (U.P.C. Prefix 5)**


**Application Description**

GS1 US coupon identification consists of the actual coupon identification data and supplementary information represented in a GS1-128 Coupon Extended Bar Code. The *Application Standard for UCC Coupon Codes* provides detailed information on data contents and applied codes.

- Note:** GS1 US coupon identification is used in the United States and Canada and cannot be used beyond their boundaries.

**Figure 2.6.5 - 1**

Format of the Element String				
U.P.C. Prefix	Company Number	Family Code	Value Code	Check Digit
5	N <sub>2</sub> N <sub>3</sub> N <sub>4</sub> N <sub>5</sub> N <sub>6</sub>	N <sub>7</sub> N <sub>8</sub> N <sub>9</sub>	N <sub>10</sub> N <sub>11</sub>	N <sub>12</sub>

- The U.P.C. Prefix 5 denotes the Element String for GS1 US coupon identification.
  - The Company Number is that of the company issuing the coupon for redemption if a product symbol marked with the same Company Number in the item identification number has been purchased.
  - The Family Code is used to validate the coupon.
  - The Value Code is the redemption value of the coupon in encoded format.
  - The Check Digit is explained in Section 7.10. Its verification, carried out automatically by the bar code reader, ensures that the data corresponds with the verification rules.
  - The data carrier for this Element String is the UPC-A Bar Code Symbol.
  - The system recognises this Element String by the symbology identifier **JE0** and the U.P.C. Prefix 5.
-  **Note:** The Company Number N2 to N6 uses the implied U.P.C. Prefix 0 (zero). If the coupon is applicable to a Global Trade Item Number (GTIN) beginning with a U.P.C. Prefix other than zero, an AI (8100) to (8102) (GS1-128 Coupon Extended Bar Code) must be present.
- U.P.C. Prefix 5 is reserved for use in North America only! GS1 US Coupon Code is constructed using the U.P.C. Company Prefix assigned to a given organisation. For U.P.C. Company Prefixes beginning with a digit other than zero, the presence of one of the Element Strings AI (8100), (8101), or (8102) is required.
  - See the *Application Standard for GS1 US Coupon Codes* for detailed information on GS1 US coupon code data content and applied numbers.

### GS1 Key

#### **Definition**

Not Applicable

#### **Rules**

Not Applicable

#### **Attributes**

##### **Required**

Not Applicable

##### **Optional**

Not Applicable

#### **Rules**

Not Applicable

### Data Carrier Specification

#### **Carrier Choices**

A coupon with the U.P.C. Prefix 5 is carried by the UPC-A Bar Code Symbol.

#### **Symbol X-Dimension, Minimum Symbol Height, and Minimum Symbol Quality**

See Section 5.5, Figure 5.5.2.7 – 2, GS1 System Symbol Specification Table 1.

**Symbol Placement**

Not Applicable

**Unique Application Processing Requirements**

Not Applicable

**2.6.6. GS1 US Coupon Extended Bar Code: AI (8100 - 8102)****Application Description**

Element Strings AI (8100) to AI (8102) represents supplementary data related to a particular GS1 US Coupon Code using the U.P.C. Prefix 5. They are never used as a stand-alone Element String.

The Element String AI (8100) enables the representation of an Offer Code and the extension of the use of GS1 US Coupon Codes to companies who's U.P.C. Company Prefix does not begin with the U.P.C. Prefix 0.

The Element String AI (8101) enables the representation of an Offer Code and expiration data, and extends the use of GS1 US Coupon Codes to companies whose U.P.C. Company Prefix does not begin with the U.P.C. Prefix 0.

The Element String AI (8102) enables the extension of the use of GS1 US Coupon Codes to companies who's U.P.C. Company Prefix does not begin with the U.P.C. Prefix 0.

See the *Application Standard for GS1 US Coupon Codes* for detailed information on data content and applied numbers.

**GS1 Key****Definition**

Not Applicable

**Rules**

Not Applicable

**Attributes****Required**

See Section 3.2 for List of all GS1 Application Identifier, GS1-128 Coupon Extended Bar Code: AIs (8100 - 8102).

**Optional**

Not Applicable

**Rules**

Not Applicable

**Data Carrier Specification****Carrier Choices**

The GS1 US Coupon Extended Bar Code, AIs (8100 to 8102), is carried by the GS1-128 Bar Code Symbol.

**Symbol X-Dimension, Minimum Symbol Height, and Minimum Symbol Quality**

See Section 5.5, Figure 5.5.2.7 - 5, GS1 System Symbol Specification Table 4.

### **Symbol Placement**

Not Applicable


### **Unique Application Processing Requirements**

For a description of processing requirements, see Section 7.

## **2.6.7. Coupon Code Identification for Use in North America (AI 8110)**

### **Application Description**

The current U.P.C. Prefix 5 coupon system (Section [2.6.5](#)) dates back to 1985. Along the way, there have been significant changes in the system itself, such as the addition of the Coupon Extended Code in 1997 (Section [2.6.6](#)). Over 200 billion paper coupons are processed annually.

 **Note:** This application, identified using AI (8110), will lead to the replacement of the U.P.C. Prefix 5 system in 2010. The new system will initially be rolled out in the form of paper coupons.

See the *U.S. Coupon Application Guideline using GS1 DataBar (RSS) Expanded Symbols* for detailed information on GS1 U.S. coupon code data content and migration.

A stimulus for change is the fact that GS1 US has begun issuing variable-length GS1 Company Prefixes and retailers are expected to accept imported products identified with GS1 Company Prefixes. Both changes will lead to an increasing number of coupon mis-redemptions if the full Company Prefix is not processed. This will impact retailers, manufacturers, and coupon processing agents.

The new coupon format has a large number of fields (many of them optional) for specifying the more complex coupon offers in use today. Data encoded in the coupon bar code is used to identify the source (typically a manufacturer) producing the coupon, the conditions for fulfilling the offer and the specific save value offered to the consumer.

## **2.6.8. Refund Receipts**

### **Application Description**

Refund Receipts are vouchers produced to automate payment for returned empty containers.

Refund Receipts automate and expedite the handling of empty containers (e.g., bottles, crates) that have a refund value in a retail store.

When customers return empty containers (that have a refund value), the containers have to be checked and valued. This process can be done manually or by automated equipment capable of handling empty containers. When the returned containers have been valued, a Refund Receipt is printed and given to the customer. The customer presents the Refund Receipt at the store checkout, and the corresponding amount is refunded in cash or deducted from the customer's bill.

An EAN-13 Bar Code Symbol can be printed on the Refund Receipt to encode the required data including a security number and the monetary value.

The structure of Refund Receipts ensures uniqueness against all other GS1 System ID numbers only when used within the restricted environment defined by the appropriate GS1 Member Organisation.

The GS1 Prefix 980 has been released for use with Refund Receipt data.

The internationally agreed standard for GS1 System Refund Receipt data is shown in 2.6.8 - 1.

**Figure 2.6.8 – 1**

GS1 Prefix	Refund Receipt Data (Structure Determined by GS1 Member Organisation)	Check Digit
9 8 0	N <sub>4</sub> N <sub>5</sub> N <sub>6</sub> N <sub>7</sub> N <sub>8</sub> N <sub>9</sub> N <sub>10</sub> N <sub>11</sub> N <sub>12</sub>	N <sub>13</sub>

Within this structure, each GS1 Member Organisation develops its own national Refund Receipt solution. The recommended structure shown in Figure 2.6.6 – 2 provides some degree of equipment standardisation.

**Figure 2.6.8 – 2**

Prefix	Recommended Structure	Check Digit
9 8 0	S S S S S V V V V	C

Where: **S** = security number.

This number is used to provide some security in the handling of the Refund Receipt. For example, it consists of a sequential number, which is incremented by 1, for each ticket generated. In this case, the Point-of-Sale system will be able to recognise a Refund Receipt that had already been refunded. The security number can also include a two-digit machine number and a three-digit sequential number, in the case where several machines are available to the customers at the same location.

**V** = monetary value of the refund. The scale factor (decimal places) will depend on the currency used.

**C** = Check Digit. Calculated according to the standard algorithm

**GS1 Key**

**Definition**

Not Applicable

**Rules**

Refund Receipt specifications are flexible and have been designed to cater for current and future requirements.

Due to the nature of Refund Receipt identification, several national solutions are offered, each of which is defined by the respective GS1 Member Organisation. National Refund Receipt solutions are not unique worldwide and must be operated in the restricted circulation defined by the GS1 Member Organisation.

**Data Carrier Specification**

**Carrier Choices**

EAN-13 Bar Code Symbols are used with Refund Receipts.

**Symbol X-Dimension, Minimum Symbol Height, and Minimum Symbol Quality**

See Section 5.5, Figure 5.5.2.7 – 2, GS1 System Symbol Specification Table 1.

**Symbol Placement**

Not Applicable

## Unique Application Processing Requirements

For a description of processing requirements, see Section 7.

### 2.6.9. Electronic Serial Identifier for Cellular Mobile Telephones (CMTI): AI (8002)

#### Application Description

The purpose of an electronic serial identifier, AI (8002), for cellular mobile telephones (CMTI) is to uniquely identify a cellular phone within a given jurisdiction.

The information from the bar code symbol can be used to automate and speed up the capture of CMTIs. CMTIs are usually assigned by a national or pluri-national authority. Issuing authorities must ensure that the electronic serial identifier is unique for each cellular phone. However, because electronic serial identifiers are assigned by different issuing authorities, they are not unique worldwide. An electronic serial identifier, AI (8002), is assigned by the appropriate national or pluri-national body and can be carried by a bar code symbol placed directly on the cellular phone. The electronic serial identifier, AI (8002), is unique for each cellular telephone within the jurisdiction of the issuing body.

#### GS1 Key

##### **Definition**

Not Applicable

##### **Rules**

Not Applicable

#### Attributes

##### **Required**

See Section 3.2 for List of all GS1 Application Identifier, Cellular Mobile Telephone Identifier: AI (8002).

##### **Optional**

Not Applicable

##### **Rules**

Not Applicable

#### Data Carrier Specification

##### **Carrier Choices**

The electronic serial identifier for Cellular Mobile Telephones (CMTI), AI (8002), is carried by the GS1-128 Bar Code Symbol.

##### **Symbol X-Dimension, Minimum Symbol Height, and Minimum Symbol Quality**

See Section 5.5, Figure 5.5.2.7 - 5, GS1 System Symbol Specification Table 4.

##### **Symbol Placement**

Not Applicable

## Unique Application Processing Requirements

Not Applicable

## 2.6.10. Numbering and Symbol Marking for Payment Slips

### Application Description

A Payment slip is that part of a paper invoice used to facilitate payment. Payment slips cover a wide range of payment demands, such as telephone bills, electricity bills, and insurance renewals. The Payment slip is normally issued by a service provider (the invoicing party) to a final customer (the invoicee) and represents a payment demand. Normally the Payment slip would outline in Human Readable Interpretation:

- Details of the customer
- Details of the service provider
- A detailed invoice for the service(s) provided
- A reference number
- The amount payable
- The payment conditions (e.g., pay before date, where to pay)

### GS1 Key

#### Definition

Not Applicable

#### Rules

Not Applicable

### Attributes

#### Required

- **Global Location Number of the Invoicing Party** – The Application Identifier (AI) to indicate the Global Location Number (GLN) of the invoicing party is AI (415) (see Section 3). The GLN of the invoicing party identifies the issuer of the payment slip. It is used as a key to access database information about the invoicing party (normally held by the payment receiving agency). The same GLN is used for all payment slips issued by the invoicing party under identical payment conditions. The GLN of the invoicing party is used by the payment receiving agency to reference the characteristics of the contract with the invoicing party, such as:
  - Whether the payment can be accepted
  - Contact details of the invoicing party
  - Action to take if the due date has expired
  - Transfer arrangement of funds to the invoicing party's bank

A different GLN shall be used whenever the payment conditions are different. For more information, see Section 4.

- **International Bank Account Number (IBAN): AI (8007)** – The Application Identifier to indicate the International Bank Account Number (IBAN) is AI (8007). See Section 3.2 for List of all GS1 Application Identifier.

The bank account identifier of the invoicing party is defined in ISO 13616. It is used to identify where to send the payment and, in the receiving country, which bank holds the account for international bank payment.

- **Payment Slip Reference Number: AI (8020)** – The Application Identifier to indicate a payment slip reference number is AI (8020). See Section 3.2 for List of all GS1 Application Identifier.

By their nature, payment slips need to be individually tailored for the invoicee and, therefore, require a unique reference number, the payment slip reference number, AI (8020). Reminder notices should use the same number as the original notice. The payment slip reference number, (AI (8020)), is issued by the invoicing party and is a unique number in the system. Payment slip reference numbers, AI (8020), should be sequentially allocated.

The payment slip reference number, AI (8020), uniquely identifies the payment slip when used in conjunction with the Global Location Number (GLN) of the invoicing party. It is used to communicate details of payment among all the partners involved: invoicing party, invoicee, payment receiving agency, and banks. It is also used to access locally held information.

- **Amount Payable** – There are two Application Identifiers to indicate the amount payable:
  - AI (390n) = amount payable for a single monetary area. See Section 3.2 for List of all GS1 Application Identifier.
  - AI (391n) = amount payable with ISO three-digit currency code. See Section 3.2 for List of all GS1 Application Identifier.

(n = indicates the implied decimal point position)

If the amount payable is expressed in a bar code symbol, AI (391n) should be used, as this ensures the currency of the payment can be automatically processed and verified by the system. However, if the currency is unambiguously implied by the system, AI (390n) may be used. To avoid ambiguity, only one AI encoding the amount payable shall be used, and the currency must be clearly indicated in human readable form.

Scanning systems should have the facility to override the amount payable. This functionality is required should the invoicee wish to make the minimum required payment, which could be less than the total amount due. The amount due is attribute information and, when used, must be processed with the Global Location Number (GLN) of the invoicing party.

- **Due Date for Amount on Payment Slip** – The Application Identifier to indicate the due date is AI (12). See Section 3.2 for List of all GS1 Application Identifier.

The due date indicates the date by which the invoice should be paid (by the invoicee). It is attribute information and, when used, must be processed with the Global Location Number (GLN) of the invoicing party.



**Note:** The due date must be represented in the YYMMDD format in the bar code symbol; however, the Human Readable Interpretation can be presented in whatever form is appropriate.

### **Optional**

Not Applicable

### **Rules**

See Section 4, Mandatory Association of Element Strings.

### **Data Carrier Specification**

#### **Carrier Choices**

The GS1-128 Bar Code Symbol is used with Payment slips. They in no way replace the need for the Human Readable Interpretation.

**Symbol X-Dimension, Minimum Symbol Height, and Minimum Symbol Quality**

To facilitate efficient scanning, all bar code symbols shall be printed at an X-dimension between 0.25 mm (0.00984 in.) and 0.495 mmmm (0.0195 in.) and be a minimum of 13 mm (0.5 in.) in height. See Section 5.5, Figure 5.5.2.7 - 5, GS1 System Symbol Specification Table 4.

**Symbol Placement**

No standard placement. Figure 2.6.10 - 1 is an example of numbering and symbol marking for payment slips.

Figure 2.6.10 - 1



- **Example: (415) 5412345678908** – AI (415) indicates the Global Location Number (GLN) of the invoicing party.  
 The GLN is a fixed length 13-digit number terminated by a standard Check Digit. The rules for allocating GLNs ensure that this number is unique worldwide. GLNs are used by the payment receiving agent to distinguish between payment slips that can and cannot be accepted.
- **Example: (12) 010425** – AI (12) indicates the due date by which the payment should made.  
 The due date is always encoded YYMMDD; however, other formats may be used for the Human Readable Interpretation equivalent. The use of the due date is optional, but if used, the payment receiving agent and the invoicing party should agree about what action will be taken if the due date has expired.
- **Example: (3911) 710125** – AI (3911) indicates the amount payable with ISO currency number. From ISO 4217, “710” indicates South African Rand.  
 It is strongly recommended to use the ISO currency number when encoding this optional data element. The fourth digit of this AI is the decimal point indicator. For example, the digit 1 in this position would indicate one digit after the decimal point; a 2 would indicate two digits after the decimal point.
- **Example: (8020) ABC123** – AI (8020) indicates the payment slip reference number.  
 The payment slip reference number, AI (8020), is a mandatory data element for this application. It is processed with the GLN of the invoicing party and provides a unique reference for all communications between the payment agent and the invoicing party.

**Unique Application Processing Requirements**

Not Applicable

## 2.6.11. Customer Specific Articles

### 2.6.11.1. Introduction

The GS1 System guidelines for trade items (see Section [2.1](#)) state that each item of trade is assigned a non-significant number that uniquely identifies the item in an unrestricted environment. The same number is used to identify a series of identical items, with every variant being allocated a separate unique identification number whenever the variation is apparent and significant between partners in the supply chain or to the final user.

This system enables the use of Automatic Data Capture (ADC) and Electronic Data Interchange (EDI) in an open environment, globally. However, in a number of business sectors, because of the vast number of possible manifestations of certain made-to-order articles, pre-allocation of Global Trade Item Numbers (GTINs) at the lowest level is not feasible.

For organisations that trade in such made-to-order products, GS1 in association with trade representatives has developed the following guidelines. They have been designed to improve supply chain efficiency by enabling ADC and, in particular, efficient ordering via EDI.

These guidelines are fully compatible with, and should be treated as a special case of, the GS1 System recommendations for the numbering and symbol marking of trade items.

### 2.6.11.2. Application Overview

#### 2.6.11.2.1. Definition

A customer specific article (CSA) is broadly defined as any item where the supplier defines all possible manifestations of the article from which the customer may choose, and pre-allocation of article numbers at the lowest level is not feasible. CSAs are never made for stock, and hence are always made to order. However, made-to-order articles are not necessarily customer specific, but could be standard.

A typical example of a CSA is a chair that is available in 300 different types of upholstery for the seat, back, and armrest. This list of available upholstery could also be used for other types of furniture the supplier offers. There are 27,000,000 ordering possibilities for this chair (300 x 300 x 300). Typically the supplier's catalogue lists a generic style of chair as well as the 300 different upholstery options. The customer chooses the style of chair and selects upholstery for the seat, back, and armrest.

On receipt of order, the supplier produces the customer specific chair and makes it available to the customer. Because the supplier defines the customer's options, and because the customer must specify his or her choices based on those options, the order contains all the information the supplier requires to manufacture the chair. This example highlights four separate process steps:

- The supplier makes available all the possible manifestations of an article.
- The customer specifies the actual article required using the supplier catalogue.
- The supplier manufactures the article in accordance with the customer's specifications.
- The CSA is delivered.
- The GS1 System has formalized this process, enabling efficient Automatic Data Capture (ADC) and Electronic Data Interchange (EDI) throughout the supply chain. The CSA data model is based on the assumption that the supplier defines the possible components (either in a paper or electronic catalogue) and the customer specifies the actual article required.

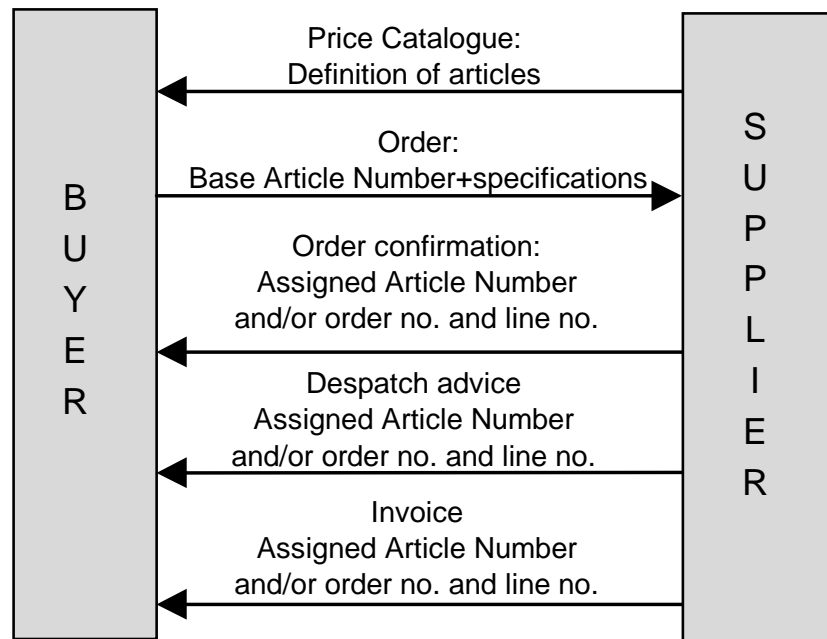
The processes for identifying and ordering the article are dealt with separately. Although these processes are closely related, each requires separate consideration in an open system.

### 2.6.11.2.2. Customer Specific Articles Data Flow

The data flow model is organised on a series of assumptions designed to ensure that the model is independent of the type of article and the sector: It is a generic model. Because many different procedures may be applied by various manufacturers, the generic model is meant to be a general guide. By using this model, companies can communicate in a standard way and (re)organise the automated handling of customer specific article (CSA) specification according to this guideline.

The model assumes that the supplier informs the customer of all available ordering options and specifications. This is achieved by means of an electronic catalogue (see Figure 2.6.11.2.2 - 1). From this catalogue the customer can determine which article(s) to order. In the order message the base article number and the chosen specifications are communicated.

Figure 2.6.11.2.2 - 1



In the order confirmation, the supplier may confirm that the article ordered can be manufactured (that is, that the buyer has made a correct combination of specifications). This should be the case assuming the customer has up-to-date database information. The order confirmation may also be used to notify the customer of the assigned article number. The assigned article number may be used in all subsequent communications. For example, the despatch advice and invoice messages use the assigned article number and, if required, the order number plus the order line number to establish an unambiguous link with the CSA.

The article produced may not be numbered with a string of numbers representing the base article number plus the applicable specifications (see Section [2.6.11.4.5](#)).

### 2.6.11.3. Allocating System Numbers for Customer Specific Articles

#### 2.6.11.3.1. General Rule

Each different product must be identified by a unique number. This implies that each variant of a product is assigned a different number. For example, each different size or colour of a garment has its own individual identification number. Article numbers should be sequentially allocated for this purpose

### 2.6.11.3.2. Ordering of Customer Specific Articles

The ordering process of customer specific articles (CSAs), the customer specification process, is based on a supplier's catalogue definitions. Internal identification systems are often manual and become increasingly complex and prone to error as the number of trading partners increases. In addition, the use of internal codes can be cumbersome, inflexible, and prone to duplication among different suppliers. These recommendations, which are based on the open systems principle, seek to avoid internally-based systems. Catalogue products using GS1 System identification numbers are guaranteed to be uniquely identifiable worldwide.

A customer specific articles *EANCOM* user profile for the price catalogue (PRICAT), orders (ORDERS), and the response to order (ORDRSP) messages have been published that use the numbering system outlined in the following subsections.

### 2.6.11.4. Base Article Number

A supplier assigned base article number is given to each generic product type for ordering purposes. A GTIN-13 is used for this functionality. The GTIN-13 is defined by the supplier and must be unique with respect to all other GS1 System identification numbers. Because it does not identify an item, the base article number will never be carried by a bar code symbol on an article. It is solely used for ordering purposes.

The base article number indicates to the customer that a number of supplier defined questions have to be answered by the customer. These specifications (questions and associated answers), which are relevant to a base article number, are communicated via an electronic catalogue. The specifications available for each different article are defined by the supplier.

#### 2.6.11.4.1. Specifications

Specifications are linked to the different base article numbers for the purposes of ordering. The same specifications may be used with different base article numbers. Specifications fall into one of the categories described in the following subsections.

#### 2.6.11.4.2. Option

An option is a specification with a discrete value that is pre-defined by the supplier and associated with a base article number.

Each option may be identified with a GTIN-13. The GTIN-13 is defined by the supplier and must be unique with respect to all other GS1 System identification numbers. An ID number of an option will never be carried by a bar code symbol on an article. It solely is used for communication purposes.

Options, such as red leather seat covers, may be valid for different base articles.

#### 2.6.11.4.3. Parameter

A parameter is a specification within a range of values (e.g., dimensions) ranging from a minimum to a maximum and including a step size.

Each parameter may be identified with a GTIN-13. The GTIN-13 is defined by the supplier and must be unique with respect to all other GS1 System identification numbers. The parameter identification will never be carried by a bar code symbol on an article. It is solely used for ordering purposes.

Parameters should be communicated using the standard *EANCOM* syntax and should be related to a base article number.

#### 2.6.11.4.4. Part

A part is a physical article that may also be ordered separately.

Parts are identified within Global Trade Item Identification Numbers (GTINs). The GTIN-13 for the part may be used in association with a base article number to create a composite, an article made up of one or more individual parts.

A part may be associated with a number of different base articles.

#### 2.6.11.4.5. External References

An external reference is often required for a customer-designed or custom-made item. External references are specified through a separate, non-EDI communication channel, such as a fax or CAD/CAM drawing. A secondary source can be used to communicate a set of customer-defined specifications (not pre-defined by the supplier).

#### 2.6.11.4.6. Data Carrier

GS1 System identification numbers used to identify customer specific articles (CSAs) for ordering purposes may never be carried by a bar code symbol on the physical article. However, suppliers may wish to utilise bar code scanning as part of the order process. This may be achieved by representing base articles and identification numbers in machine readable form in a paper catalogue. GS1-128 Bar Code Symbols, utilising an Application Identifier for internal applications, should be used for this purpose.

### 2.6.11.5. Identification of the Physical Article Actually Produced

#### Application Description

In environments with automated systems the physical article needs to be identified and the identification of the produced article is required in machine readable form (as a bar code symbol). The identification of the physical article must be communicated from the supplier to the customer. Both supplier and customer should be able to use the same identification number and each needs to keep a record of this number.

For open systems, the most appropriate identification number is the GTIN-13. Identifying a physical article with a GTIN-13 and a bar code symbol allows customer specific articles (CSAs) to be integrated within a system that manages all other items identified using the GS1 System. During order confirmation, the supplier assigns GTIN-13 to the product. It is not necessary to pre-assign numbers to all possible articles, only to those that are actually produced.

Each different product must be identified by a unique number. This implies that each variant of a product is assigned a different number. For example, each different size or colour of a garment has its own individual identification number. Article numbers should be sequentially allocated for this purpose.

#### GS1 Key

##### *Definition*

The Global Trade Item Number (GTIN) is the GS1 Identification Key used to identify trade items. The key is comprised of a GS1 or U.P.C. Company Prefix followed by an Item Reference Number and a Check Digit.

##### *Rules*

All the GTIN Allocation Rules described in Section 4; in addition, the main bar code symbols on books and paperbacks must not be reduced in height.

## Attributes

### **Required**

Not Applicable

### **Optional**

Not Applicable

## Data Carrier Specification

### **Carrier Choices**

The bar code symbol requirements for customer specific articles (CSAs) are the same as those for trade items. The data carrier used to carry the GS1 System identification number of a physical article shall be one of the following:

- EAN-13, or UPC-A Bar Code Symbol
- ITF-14 Bar Code Symbol
- GS1-128 Bar Code Symbol (attribute information always uses GS1-128 Bar Code Symbols)

With CSAs, the choice of data carrier is left to the discretion of the organisation responsible for issuing the GS1 System identification number. Trade items that will be scanned at a Point-of-Sale always should be marked using the EAN/UPC Symbology.

### **Symbol X-Dimension, Minimum Symbol Height, and Minimum Symbol Quality**

See Section 5.5, Figure 5.5.2.7 - 2, GS1 System Symbol Specification Table 1.

### **Symbol Placement**

Not Applicable

## Unique Application Processing Requirements

For a description of processing requirements, see Section 7.

## 2.6.12. Custom Trade Item

### 2.6.12.1. Allocating System Numbers for Custom Trade Items

#### 2.6.12.1.1. General Rule

Customer Specific Items, as described in the previous section, (Section 2.6.10) are configured from a wide variety of known parameters. Things like colour, size, model, and various materials are listed and uniquely identified. A Customer Specific Item is created when a selection is made from each category, sufficient to create the item. Customer Specific Items may be intended for the end consumer (e.g. furniture) and can be marked with a GTIN and data carrier appropriate for Point of Sale (POS).

Custom made-to-order trade items are different than Customer Specific Items, however, in that they are one-of-a-kind, made-to-order items that are strictly sold from business to business. Their use is approved for the Maintenance, Repair and Operations (MRO) environment, also known as industrial supplies. Examples include custom abrasive belts, special adhesives, and made-to-order cutting tools needed for a specific machine and cutting application. Their specifications may be called out in a series of blue prints or other technical documents.

Each different product must be identified by a unique number. If a trade item is a stock trade item, it is assigned the appropriate fixed measure GTIN. If any trade item, custom or not, will be scanned at POS, then it must be assigned a GTIN-12, GTIN-8, or GTIN-13 and represented in a bar code

symbology approved for POS. At the discretion of the supplier, it is always acceptable to use a GTIN-12, GTIN-8 or GTIN-13 to identify a trade item, whether custom or not. In other words, a supplier or manufacturer is not required to use the method described below to identify a custom item. They may give each and every different trade item a unique GTIN. However, this will deplete their pool of possible GTIN more quickly.

This method of assigning unique product identification uses a base GTIN-14, Indicator Digit 9 which signifies a GTIN with a variable component (i.e. it is a custom, made-to-order item), followed by a Made-to-Order Variation Number. The Made-to-Order Variation Number is a variable length, numeric field up to six digits. This allows each base GTIN-14, Indicator Digit 9 to be used for 1,000,000 different custom variations. Multiple items, made to the same specifications could have the same combination of the base GTIN-14, Indicator Digit 9 and Made-to-Order Variation Number.

### **2.6.12.1.2. Ordering of Custom Trade Items**

A supplier or manufacturer may indicate in their paper or electronic catalogue that certain items can be ordered based on customer specifications. A GTIN-14, Indicator Digit 9 can be assigned to denote that it is possible to order a customized version of this trade item. However, in this case, no physical item exists. When the order is accepted for the made-to-order custom item, a Made-to-Order Variation number is assigned to this specific version. Multiples of this same item may be ordered at one time. It is the combination of the GTIN-14, indicator digit 9 and the Made-to-Order Variation Number that uniquely identifies the custom items.

#### **2.6.12.1.2.1. Custom Trade Item Number**

A GTIN-14, Indicator Digit 9 indicates a variable measure trade item. Additional information is needed to complete the identification of the trade item. A custom trade item number is the combination of a GTIN-14, Indicator Digit 9, and the Made-to-Order Variation Number. This combination is used in electronic business transactions and in bar code representation. When many items with the exact same specifications are manufactured at one time, they will each carry the same combination of GTIN-14, Indicator Digit 9 and Made-to-Order Variation Number.

#### **2.6.12.1.2.2. Base GTIN-14**

To indicate that a trade item is available in a custom format, a base GTIN-14, Indicator Digit 9, is used. A base GTIN-14, Indicator Digit 9 may appear in the supplier's paper or electronic product catalogue to indicate the possibility of a custom item. This GTIN does not identify a specific trade item, but a general category of possible custom trade items. The description indicates that this is a custom, made-to-order item. A manufacturer may create one GTIN-14, Indicator Digit 9 to represent any and all made-to-order trade items, or they may assign one for each category of custom items (Custom Abrasive Belts, Custom Abrasive Pads, etc.). Further a manufacturer may choose to create a GTIN-14 Indicator Digit 9 for sub-categories (Custom Abrasive Belts, 1 to 2 Inches Wide; Custom Abrasive Belts, 2 to 3 Inches Wide, and so on).

#### **2.6.12.1.2.3. Made-to-Order Variation Number**

Once the specifications for a custom trade item are agreed upon between the customer and the manufacturer, the manufacturer will assign a Made-to-Order Variation Number to that custom item. A Made-to-Order Variation number is always used with a GTIN-14, Indicator Digit 9.

The Made-to-Order Variation Number is communicated from the manufacturer to the customer during the Request for Quote / Response to Request for Quote process or on a Purchase Order Acknowledgement or by some other mutually agreed upon method. In a bar code representation, Application Identifier AI (242) is used to denote a Made-to-Order Variation Number. The Made-to-Order Variation Number is numeric and variable length up to, and including, six digits.

A Made-to-Order Variation Number will never appear alone, but must always be associated with the appropriate GTIN-14, Indicator Digit 9. Further, a Made-to-Order Variation Number may not be used with GTIN-8, GTIN-12, GTIN-13, and GTIN-14 Indicator Digit 1 through 8.

The use of a GTIN-14, Indicator Digit 9 and a Made-to-Order Variation Number is only approved for the Maintenance, Repair, Operations and Production (MROP) industrial supply sector.

#### 2.6.12.1.2.4. Data Carrier

GS1 System identification numbers used to identify custom made-to-order items in the manufacturing, pick, pack, shipping, receiving and inventory management process may be carried by a bar code symbol on the physical article. This may be achieved by representing identification numbers in machine readable form. GS1 Bar Code Symbols, utilising Application Identifiers should be used for this purpose.

### 2.6.12.2. Identification of the Physical Article Actually Produced

#### Application Description

In environments with automated systems the physical article needs to be identified and the identification of the produced article is required in machine readable form (e.g. as a bar code symbol). The identification of the physical article must be communicated from the supplier to the customer. Both supplier and customer should be able to use the same identification number and each needs to keep a record of this number.

For open systems, the appropriate identification number for a custom trade item is the base GTIN-14 Indicator Digit 9, followed by a Made-to-Order Variation Number. During order confirmation, the supplier assigns the Made-to-Order Variation Number to this version of the product.

Products made to the same specifications can carry the same combination GTIN-14, Indicator Digit 9, and Made-to-Order Variation Number.

#### GS1 Key

##### *Definition*

The Global Trade Item Number (GTIN) is the GS1 Identification Key used to identify trade items. The base GTIN-14, Indicator Digit 9 in combination with the Made-to-Order Variation Number comprises the key for a custom trade item. The base GTIN-14 is comprised of Indicator Digit 9, GS1 Company Prefix followed by an Item Reference Number and a Check Digit. The Made-to-Order Variation number is variable length, numeric, up to and including six digits.

#### Attributes

##### *Required*

Not Applicable

##### *Optional*

Not Applicable

#### Data Carrier Specification

##### *Carrier Choices*

The combination of a GTIN-14, Indicator Digit 9, and a Made-to-Order Variation Number, can be carried by using the appropriate Application Identifiers in the following symbologies:

- GS1-128
- GS1 DataBar

- GS1 DataMatrix

AI (01) is used for the GTIN-14, Indicator Digit 9, plus AI (242) for the Made-to-Order Variation Number when the item is considered a trade item. The combination of AI (02) plus AI (242) and AI (37) Count of Trade Items Contained in a Logistic Unit, is used in conjunction with an (00) Serial Shipping Container Code when marking a logistics unit of custom trade items.

***Symbol X-Dimension, Minimum Symbol Height, and Minimum Symbol Quality***

See Section 5.5, - Figure 5.5.2.7 – 2, GS1 System Symbol Specification Table 1.

***Symbol Placement***

Not Applicable

## 2.6.13. Global Document Type Identifier (Numbering & Symbol Marking for Document Control)

### Application Description

The term “document” is applied broadly to cover any official or private papers that infer a right (e.g., proof of ownership) or obligation (e.g., notification or call for military service) upon the bearer. The issuer of the document is normally responsible for all the information contained upon the document, both bar coded and Human Readable Interpretation. Such documents typically require storage of the appropriate information contained on the document. Examples include:

- Land registration papers
- Tax demands
- Proof of shipment/receipt forms
- Custom’s clearance forms
- Insurance policies
- Internal invoices.
- National press documents
- Educational papers
- Transporting company documents
- Mail companies documents
- Among others

### GS1 Key

#### ***Definition***

The Application Identifier to indicate the Global Document Type Identifier (GDTI) is AI (253) (see Section 3.2 for List of all GS1 Application Identifier).

#### ***Rules***

The GDTI is assigned by the document issuer. The GDTI is used as a key to access database information that is required for document control purposes (normally held by issuing organisation). The same GDTI is used for all document classes that are issued with an identical purpose. This can then be used to reference the characteristics of the document, such as:

- The issuer of the document
- The exact right or obligation the document imposes

- The document type (e.g., insurance policy, governmental paper)

A different GDTI shall be used whenever characteristics of the document are different.

### **Attributes**

#### **Required**

Not Applicable

#### **Optional**

By their nature, each document needs to be individually tailored for the intended recipient and, therefore, requires a unique reference number in addition to the GDTI. Any duplicates of a document should use the same number as the original. The serial component is optional and assigned by the document issuer and is a unique number in a series of documents issued under the same GDTI. Ideally the serial component should be sequentially allocated for each new document generated.

The serial component is used to communicate exact details pertinent to the individual document, such as:

- The name and address of the recipient
- The cross-reference to individual details

Refer to Section 3 for detailed information.

### **Data Carrier Specification**

#### **Carrier Choices**

The GS1-128 Bar Code Symbol is used for documents that require control. The bar code in no way replaces the need for the Human Readable Interpretation.

#### **Symbol X-Dimension, Minimum Symbol Height, and Minimum Symbol Quality**

To facilitate efficient scanning, all bar code symbols shall be printed at an X-dimension between 0.25 mm (0.00984 in.) and 0.495 mm (0.0195 in.) and be a minimum of 13 mm (0.5 in.) in height. See Section 5.5, Figure 5.5.2.7 - 5, GS1 System Symbol Specification Table 4.

#### **Symbol Placement**

No standard placement. The following are examples of numbering and symbol marking for document control:

**Example 1: Legally Required Declaration Prior to Travel**

This example shows how GS1-128 Bar Code Symbols can be used to automate the capture of information for traveller who enters or leaves the country.

Figure 2.6.13 - 1 Legally Required Travel Declaration

## Declaration of Luggage and Money of Travellers

( 253) 770721248998412345678901


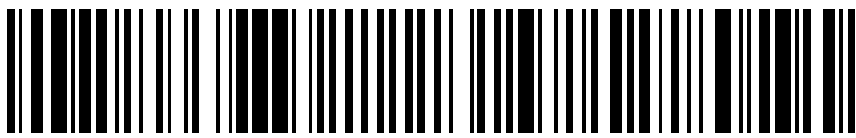
Name:			
Address:			
Date of Entrance:			
Items to Declare:			
Amount	Description	Value	Customs Value
I have read the instructions and declare the truth:			
Date and Signature:			

Doc Type: 12345678901

**Example 2: Insurance Policy**

This example shows how GS1-128 Bar Code Symbols can be used to automate the capture of information on insurance policies. This standard solution provides benefit for the insurer, the insured, and any potential beneficiaries as well as facilitates the automation of any monitoring and inspection of the requirement to fulfil the legal norms.


Figure 2.6.13 - 2 Insurance Policy

Policy Number:  67890543210987	
<b>Branch:</b> Bogotá	<b>Date of Policy:</b> March 23, 2005
<b>Name:</b> Name of Insured	
<b>Age:</b> 24	<b>Valid From:</b> March 23, 2005
	<b>Valid To:</b> March 22, 2007
<b>Contract Cover:</b> Life	<b>Value:</b> 10,000
<div style="border: 1px solid black; height: 60px; width: 100%;"></div>	
 <p>( 253 ) 770999800010067890543210987</p>	

### Example 3: Application Form


This example shows how GS1-128 Bar Code Symbols can be used to automate the capture of information on application forms. Many organisations require their clients to complete an application form.

Figure 2.6.13 - 3 Membership Application Form



**Este formulario es GRATIS. Solicítalo directamente en IAC. El único Transmisor.**

**Mira una muestra de cómo se ve en Internet, así sea en muchos más sitios.**



## Solicitud de Servicios

### TIPOS DE SERVICIOS

Para que su empresa pueda identificar productos, servicios o localizaciones, el Instituto Colombiano de Certificación y Automatización Comercial IAC Colombia le ofrece varias opciones. Escoga la que más le convenga según sus necesidades.

**1. SER MIEMBRO DE IAC**  
Al ser miembro del Instituto, su empresa podrá obtener los siguientes beneficios:

- » Asignación de Código único para su empresa, con el cual podrá identificar entre 1 y 100.000 productos, servicios o localizaciones (los códigos asignados como localizaciones sirven para identificar ubicaciones o buzones para EII).
- » Voz y voto en la Asamblea Anual de Miembros de IAC Colombia.
- » Uso gratuito de CABASnet: El primer Catálogo Electrónico de Productos.
- » Tarifas especiales en los cursos, seminarios y consultorías que realiza el Instituto.
- » Recordos básicos por TecnoEAV, el único modelo real y didáctico de una Cadena de Abastecimiento en Colombia.
- » Navegar en el área privada de nuestra página Web [www.iaccolombia.org](http://www.iaccolombia.org), en la cual puede acceder a la información especializada que le ofrece el Instituto.
- » Tarifas preferenciales para entrar en el Directorio de Soluciones Logísticas para la Cadena de Abastecimiento.

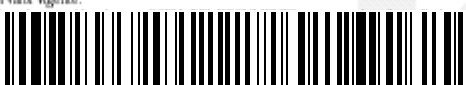
**2. SER CLIENTE DE IAC**  
Al escoger esta opción Usted puede elegir entre cuatro opciones dependiendo de sus necesidades:

**2a. Cliente Código de empresa:** Con este tipo de vinculación su empresa adquirirá el código EAN+UCC mediante el cual podrá identificar entre 1 y 100.000 productos, servicios o localizaciones. Renovación anual.

**2b. Cliente pago por 10 años:** Con este tipo de vinculación su empresa adquirirá el código EAN+UCC mediante el cual podrá identificar entre 1 y 100.000 productos, servicios o localizaciones. Renovación cada 10 años. Válido solo para empresas con activos inferiores a 99.9 millones de pesos.

**2c. Cliente Código GTIN:** Con este tipo de vinculación su empresa adquirirá UN código para UN solo producto o UN solo servicio. Si más adelante usted desea identificar UNO adicional, debe diligenciar un formato que IAC le suministrará y cancelar el valor vigente. Código de carácter vitalicio.

**2d. Cliente Código Identificación de Documentos:** Con este tipo de vinculación su empresa adquirirá UN código para identificar UN solo documento. Si más adelante usted desea identificar UNO adicional, debe diligenciar un formato que IAC le suministrará y cancelar el valor vigente.



(253) 77012340000117654321

### Example 4: Freight-Forwarding Authorisation

This example shows how GS1-128 Bar Code Symbols can be used to automate the capture of information on freight-forwarding forms. Many organisations require documentary evidence that goods have been dispatched prior to making payment.

Figure 2.6.13 - 4 Freight-Forwarding Authorisation

<p>Suppliers or Forwarders Principals</p> <p style="text-align: center;">ID-Number barcoded (automated access to database)</p> <hr/> <p>Consigned to order of</p> <hr/> <p>Human readable information (no meaning for access to database)</p> <p>Notify address</p> <hr/> <p>Conveyance from / via</p> <hr/> <p>Destination</p> <hr/> <p>Marks and numbers</p>	<div style="text-align: center; font-size: 2em; font-weight: bold;">FIATA FCT</div> <div style="display: flex; justify-content: space-around; align-items: center;"> <div style="border: 1px solid black; border-radius: 50%; padding: 5px; text-align: center;">Emblem</div> <table border="1" style="border-collapse: collapse;"> <tr> <td style="padding: 2px;">No. 123 456</td> <td style="padding: 2px;">CH</td> </tr> </table> </div> <div style="text-align: center;"> <p>(253)7612345000008123456</p> <p style="font-weight: bold;">ID-Number human readable (manual access to database)</p> </div>	No. 123 456	CH
No. 123 456	CH		
<p>Number and kind of packages</p> <p>Description of goods</p> <p>Gross weight</p> <p>Measurement</p>			

specimen

according to the declaration of the consignor

The goods and instructions are accepted and dealt with subject to the General Conditions printed overleaf.

Acceptance of this document or the invocation of rights arising therefrom acknowledges the validity of the following conditions, regulations and exceptions also of the trading conditions printed overleaf, except where the latter conflict with conditions 1-6 below.

1. The undersigned are authorized to enter into contracts with carriers and others involved in the execution of the transport subject to the latter's usual terms and conditions.
2. The undersigned do not act as Carriers but as Forwarders. In consequence they are only responsible for the careful selection of third parties, instructed by them, subject to the conditions of Clause 3 hereunder.
3. The undersigned are responsible for delivery of the goods to the holder of this document through the intermediary of a delivery agent of their choice. They are not responsible for acts or omissions of Carriers involved in the execution of the transport or of other third parties. The undersigned Forwarders will, on request, assign their rights and claims against Carriers and other parties.
4. Insurance of the goods will only be effected upon express instructions in writing.
5. Unforeseen and/or unforeseeable circumstances entitle the undersigned to arrange for deviation from the envisaged route and/or method of transport.
6. Unforeseen and/or unforeseeable disbursements and charges are for the account of the goods.

Insurance through the intermediary or the undersigned Forwarders

Not covered

Covered according to the attached Insurance Policy / Certificate

All disputes shall be governed by the law and within the exclusive jurisdiction of the courts at the place of issue.

For delivery of the goods please apply to:

Freight and charges prepaid to:

12

thence for account of goods, lost or not lost.

We, the Undersigned Forwarders in accordance with the instructions of our Principals, have taken charge of the abovementioned goods in good external condition at: .....

for despatch and delivery as stated above or order against surrender of this document properly endorsed.

In witness thereof the Undersigned Forwarders have signed originals of this FCT document, all of this tenor and date. When one of these has been accomplished, the other(s) will lose their validity. ....

Place and date of issue

Stamp and signature

### Unique Application Processing Requirements

For description of processing requirements, see Section 7.



## Section 3. GS1 Application Identifier Definitions

- Introduction
- GS1 Application Identifiers in Numerical Order
- GS1 Application Identifiers starting with digit 0
- GS1 Application Identifiers starting with digit 1
- GS1 Application Identifiers starting with digit 2
- GS1 Application Identifiers starting with digit 3
- GS1 Application Identifiers starting with digit 4
- GS1 Application Identifiers starting with digit 7
- GS1 Application Identifiers starting with digit 8
- GS1 Application Identifiers starting with digit 9
- Compatibility of EPCglobal Tag Data Standard and GS1 General Specifications

Whilst every effort has been made to ensure that the guidelines to use the GS1 standards contained in the document are correct, GS1 and any other party involved in the creation of the document HEREBY STATE that the document is provided without warranty, either expressed or implied, of accuracy or fitness for purpose, AND HEREBY DISCLAIM any liability, direct or indirect, for damages or loss relating to the use of the document. The document may be modified, subject to developments in technology, changes to the standards, or new legal requirements.

Several products and company names mentioned herein may be trademarks and/or registered trademarks of their respective companies.

### 3.1. Introduction

This section describes the meaning, structure, and function of the GS1 System Element Strings so they can be correctly processed in users' application programmes. An Element String is the combination of a GS1 Application Identifier and a GS1 Application Identifier Data Field.

Automatic processing of Element Strings in business applications requires information about the type of transaction to which the transferred data refers. See Section 7 for an explanation of this process. Element Strings can be carried by GS1-128, GS1 DataBar Symbology, GS1 Composite, and GS1 DataMatrix Symbols ). The rules for use and interrelationships between the Application Identifiers are contained in Section 4.

### 3.2. GS1 Application Identifiers in Numerical Order

**Notes:** (\*): The first position indicates the length (number of digits) of the GS1 Application Identifier. The following value refers to the format of the data content. The following convention is applied:

- n numeric digit
- an any character in figure 7.12 – 1
- n3 3 numeric digits, fixed length
- n..3 up to 3 numeric digits
- an..3 up to 3 characters in figure 7.12 – 1

(\*\*): If only year and month are available, DD must be filled with two zeroes.

(\*\*\*): The fourth digit of this GS1 Application Identifier indicates the implied decimal point position.

Example:

- 3100 Net weight in kg without a decimal point
- 3102 Net weight in kg with two decimal points

**(FNC1):** All GS1 Application Identifiers indicated with (FNC1) are defined as of variable length and must be limited by a Function 1 Symbol Character unless this Element String is the last one to be encoded in the symbol.

Figure 3.2 - 1

AI	Data Content	Format*	FNC1 Required	Data Title
00	<a href="#">SSCC (Serial Shipping Container Code)</a>	n2+n18		SSCC
01	<a href="#">Global Trade Item Number (GTIN)</a>	n2+n14		GTIN
02	<a href="#">GTIN of Contained Trade Items</a>	n2+n14		CONTENT
10	<a href="#">Batch or Lot Number</a>	n2+an..20	(FNC1)	BATCH/LOT
11 (**)	<a href="#">Production Date (YYMMDD)</a>	n2+n6		PROD DATE
12 (**)	<a href="#">Due Date (YYMMDD)</a>	n2+n6		DUE DATE
13 (**)	<a href="#">Packaging Date (YYMMDD)</a>	n2+n6		PACK DATE
15 (**)	<a href="#">Best Before Date (YYMMDD)</a>	n2+n6		BEST BEFORE or SELL BY
17 (**)	<a href="#">Expiration Date (YYMMDD)</a>	n2+n6		USE BY OR EXPIRY
20	<a href="#">Variant Number</a>	n2+n2		VARIANT
21	<a href="#">Serial Number</a>	n2+an..20	(FNC1)	SERIAL
22	<a href="#">Secondary Data Fields</a>	n2+an..29	(FNC1)	QTY /DATE /BATCH

AI	Data Content	Format*	FNC1 Required	Data Title
240	<a href="#">Additional Item Identification</a>	n3+an..30	(FNC1)	ADDITIONAL ID
241	<a href="#">Customer Part Number</a>	n3+an..30	(FNC1)	CUST. PART NO.
242	<a href="#">Made-to-Order Variation Number</a>	n3+n..6	(FNC1)	MTO VARIANT
250	<a href="#">Secondary Serial Number</a>	n3+an..30	(FNC1)	SECONDARY SERIAL
251	<a href="#">Reference to Source Entity</a>	n3+an..30	(FNC1)	REF. TO SOURCE
253	<a href="#">Global Document Type Identifier (GDTI)</a>	n3+n13+n..17	(FNC1)	DOC. ID
254	<a href="#">GLN Extension Component</a>	n3+an..20	(FNC1)	GLN EXTENSION
30	<a href="#">Count of Items (Variable Measure Trade Item)</a>	n2+n..8	(FNC1)	VAR. COUNT
310 (***)	<a href="#">Net weight, kilograms (Variable Measure Trade Item)</a>	n4+n6		NET WEIGHT (kg)
311 (***)	<a href="#">Length of first dimension, metres (Variable Measure Trade Item)</a>	n4+n6		LENGTH (m)
312 (***)	<a href="#">Width, diameter, or second dimension, metres (Variable Measure Trade Item)</a>	n4+n6		WIDTH (m)
313 (***)	<a href="#">Depth, thickness, height, or third dimension, metres (Variable Measure Trade Item)</a>	n4+n6		HEIGHT (m)
314 (***)	<a href="#">Area, square metres (Variable Measure Trade Item)</a>	n4+n6		AREA (m <sup>2</sup> )
315 (***)	<a href="#">Net volume, litres (Variable Measure Trade Item)</a>	n4+n6		NET VOLUME (l)
316 (***)	<a href="#">Net volume, cubic metres (Variable Measure Trade Item)</a>	n4+n6		NET VOLUME (m <sup>3</sup> )
320 (***)	<a href="#">Net weight, pounds (Variable Measure Trade Item)</a>	n4+n6		NET WEIGHT (lb)
321 (***)	<a href="#">Length or first dimension, inches (Variable Measure Trade Item)</a>	n4+n6		LENGTH (i)
322 (***)	<a href="#">Length or first dimension, feet (Variable Measure Trade Item)</a>	n4+n6		LENGTH (f)
323 (***)	<a href="#">Length or first dimension, yards (Variable Measure Trade Item)</a>	n4+n6		LENGTH (y)
324 (***)	<a href="#">Width, diameter, or second dimension, inches (Variable Measure Trade Item)</a>	n4+n6		WIDTH (i)
325 (***)	<a href="#">Width, diameter, or second dimension, feet (Variable Measure Trade Item)</a>	n4+n6		WIDTH (f)
326 (***)	<a href="#">Width, diameter, or second dimension, yards (Variable Measure Trade Item)</a>	n4+n6		WIDTH (y)
327 (***)	<a href="#">Depth, thickness, height, or third dimension, inches (Variable Measure Trade Item)</a>	n4+n6		HEIGHT (i)
328 (***)	<a href="#">Depth, thickness, height, or third dimension, feet (Variable Measure Trade Item)</a>	n4+n6		HEIGHT (f)

AI	Data Content	Format*	FNC1 Required	Data Title
329 (***)	<a href="#">Depth, thickness, height, or third dimension, yards (Variable Measure Trade Item)</a>	n4+n6		HEIGHT (y)
330 (***)	<a href="#">Logistic weight, kilograms</a>	n4+n6		GROSS WEIGHT (kg)
331 (***)	<a href="#">Length or first dimension, metres</a>	n4+n6		LENGTH (m), log
332 (***)	<a href="#">Width, diameter, or second dimension, metres</a>	n4+n6		WIDTH (m), log
333 (***)	<a href="#">Depth, thickness, height, or third dimension, metres</a>	n4+n6		HEIGHT (m), log
334 (***)	<a href="#">Area, square metres</a>	n4+n6		AREA (m <sup>2</sup> ), log
335 (***)	<a href="#">Logistic volume, litres</a>	n4+n6		VOLUME (l), log
336 (***)	<a href="#">Logistic volume, cubic litres</a>	n4+n6		VOLUME (m <sup>3</sup> ), log
337 (***)	<a href="#">Kilograms per square metre</a>	n4+n6		KG PER m <sup>2</sup>
340 (***)	<a href="#">Logistic weight, pounds</a>	n4+n6		GROSS WEIGHT (lb)
341 (***)	<a href="#">Length or first dimension, inches</a>	n4+n6		LENGTH (i), log
342 (***)	<a href="#">Length or first dimension, feet</a>	n4+n6		LENGTH (f), log
343 (***)	<a href="#">Length or first dimension, yards</a>	n4+n6		LENGTH (y), log
344 (***)	<a href="#">Width, diameter, or second dimension</a>	n4+n6		WIDTH (i), log
345 (***)	<a href="#">Width, diameter, or second dimension</a>	n4+n6		WIDTH (f), log
346 (***)	<a href="#">Width, diameter, or second dimension</a>	n4+n6		WIDTH (y), log
347 (***)	<a href="#">Depth, thickness, height, or third dimension</a>	n4+n6		HEIGHT (i), log
348 (***)	<a href="#">Depth, thickness, height, or third dimension</a>	n4+n6		HEIGHT (f), log
349 (***)	<a href="#">Depth, thickness, height, or third dimension</a>	n4+n6		HEIGHT (y), log
350 (***)	<a href="#">Area, square inches (Variable Measure Trade Item)</a>	n4+n6		AREA (i <sup>2</sup> )
351 (***)	<a href="#">Area, square feet (Variable Measure Trade Item)</a>	n4+n6		AREA (f <sup>2</sup> )
352 (***)	<a href="#">Area, square yards (Variable Measure Trade Item)</a>	n4+n6		AREA (y <sup>2</sup> )
353 (***)	<a href="#">Area, square inches</a>	n4+n6		AREA (i <sup>2</sup> ), log
354 (***)	<a href="#">Area, square feet</a>	n4+n6		AREA (f <sup>2</sup> ), log
355 (***)	<a href="#">Area, square yards</a>	n4+n6		AREA (y <sup>2</sup> ), log
356 (***)	<a href="#">Net weight, troy ounces (Variable Measure Trade Item)</a>	n4+n6		NET WEIGHT (t)
357 (***)	<a href="#">Net weight (or volume), ounces (Variable Measure Trade Item)</a>	n4+n6		NET VOLUME (oz)
360 (***)	<a href="#">Net volume, quarts (Variable Measure Trade Item)</a>	n4+n6		NET VOLUME (q)
361 (***)	<a href="#">Net volume, gallons U.S. (Variable Measure Trade Item)</a>	n4+n6		NET VOLUME (g)
362 (***)	<a href="#">Logistic volume, quarts</a>	n4+n6		VOLUME (q), log

AI	Data Content	Format*	FNC1 Required	Data Title
363 (***)	<a href="#">Logistic volume, gallons U.S.</a>	n4+n6		VOLUME (g), log
364 (***)	<a href="#">Net volume, cubic inches (Variable Measure Trade Item)</a>	n4+n6		VOLUME (i <sup>3</sup> ), log
365 (***)	<a href="#">Net volume, cubic feet (Variable Measure Trade Item)</a>	n4+n6		VOLUME (f <sup>3</sup> ), log
366 (***)	<a href="#">Net volume, cubic yards (Variable Measure Trade Item)</a>	n4+n6		VOLUME (y <sup>3</sup> ), log
367 (***)	<a href="#">Logistic volume, cubic inches</a>	n4+n6		VOLUME (q), log
368 (***)	<a href="#">Logistic volume, cubic feet</a>	n4+n6		VOLUME (g), log
369 (***)	<a href="#">Logistic volume, cubic yards</a>	n4+n6		VOLUME (i <sup>3</sup> ), log
37	<a href="#">Count of Trade Items</a>	n2+n..8	(FNC1)	COUNT
390 (***)	<a href="#">Applicable Amount Payable, local currency</a>	n4+n..15	(FNC1)	AMOUNT
391 (***)	<a href="#">Applicable Amount Payable with ISO Currency Code</a>	n4+n3+n..15	(FNC1)	AMOUNT
392 (***)	<a href="#">Applicable Amount Payable, single monetary area (Variable Measure Trade Item)</a>	n4+n..15	(FNC1)	PRICE
393 (***)	<a href="#">Applicable Amount Payable with ISO Currency Code (Variable Measure Trade Item)</a>	n4+n3+n..15	(FNC1)	PRICE
400	<a href="#">Customer's Purchase Order Number</a>	n3+an..30	(FNC1)	ORDER NUMBER
401	<a href="#">Consignment Number</a>	n3+an..30	(FNC1)	CONSIGNMENT
402	<a href="#">Shipment Identification Number</a>	n3+n17	(FNC1)	SHIPMENT NO.
403	<a href="#">Routing Code</a>	n3+an..30	(FNC1)	ROUTE
410	<a href="#">Ship to - Deliver to Global Location Number</a>	n3+n13		SHIP TO LOC
411	<a href="#">Bill to - Invoice to Global Location Number</a>	n3+n13		BILL TO
412	<a href="#">Purchased from Global Location Number</a>	n3+n13		PURCHASE FROM
413	<a href="#">Ship for - Deliver for - Forward to Global Location Number</a>	n3+n13		SHIP FOR LOC
414	<a href="#">Identification of a Physical Location - Global Location Number</a>	n3+n13		LOC No
415	<a href="#">Global Location Number of the Invoicing Party</a>	n3+n13		PAY TO
420	<a href="#">Ship to - Deliver to Postal Code Within a Single Postal Authority</a>	n3+an..20	(FNC1)	SHIP TO POST
421	<a href="#">Ship to - Deliver to Postal Code with ISO Country Code</a>	n3+n3+an..12	(FNC1)	SHIP TO POST
422	<a href="#">Country of Origin of a Trade Item</a>	n3+n3	(FNC1)	ORIGIN
423	<a href="#">Country of Initial Processing</a>	n3+n3+n..12	(FNC1)	COUNTRY - INITIAL PROCESS.

AI	Data Content	Format*	FNC1 Required	Data Title
424	<a href="#">Country of Processing</a>	n3+n3	(FNC1)	COUNTRY - PROCESS.
425	<a href="#">Country of Disassembly</a>	n3+n3	(FNC1)	COUNTRY - DISASSEMBLY
426	<a href="#">Country Covering full Process Chain</a>	n3+n3	(FNC1)	COUNTRY – FULL PROCESS
7001	<a href="#">NATO Stock Number (NSN)</a>	n4+n13	(FNC1)	NSN
7002	<a href="#">UN/ECE Meat Carcasses and Cuts Classification</a>	n4+an..30	(FNC1)	MEAT CUT
7003	<a href="#">Expiration Date and Time</a>	n4+n10	(FNC1)	EXPIRY TIME
703s	<a href="#">Approval Number of Processor with ISO Country Code</a>	n4+n3+an..27	(FNC1)	PROCESSOR # s
8001	<a href="#">Roll Products (Width, Length, Core Diameter, Direction, Splices)</a>	n4+n14	(FNC1)	DIMENSIONS
8002	<a href="#">Cellular Mobile Telephone Identifier</a>	n4+an..20	(FNC1)	CMT No
8003	<a href="#">Global Returnable Asset Identifier (GRAI)</a>	n4+n14+an..16	(FNC1)	GRAI
8004	<a href="#">Global Individual Asset Identifier (GIAI)</a>	n4+an..30	(FNC1)	GIAI
8005	<a href="#">Price Per Unit of Measure</a>	n4+n6	(FNC1)	PRICE PER UNIT
8006	<a href="#">Identification of the Components of a Trade Item</a>	n4+n14+n2+n2	(FNC1)	GCTIN
8007	<a href="#">International Bank Account Number (IBAN)</a>	n4+an..30	(FNC1)	IBAN
8008	<a href="#">Date and Time of Production</a>	n4+n8+n..4	(FNC1)	PROD TIME
8018	<a href="#">Global Service Relation Number (GSRN)</a>	n4+n18	(FNC1)	GSRN
8020	<a href="#">Payment Slip Reference Number</a>	n4+an..25	(FNC1)	REF No
8100	<a href="#">GS1-128 Coupon Extended Code</a>	n4+n6	(FNC1)	-
8101	<a href="#">GS1-128 Coupon Extended Code</a>	n4+n1+n5+n4	(FNC1)	-
8102	<a href="#">GS1-128 Coupon Extended Code</a>	n4+n1+n1	(FNC1)	-
8110	<a href="#">Coupon Code Identification for Use in North America</a>	n4+an..30	(FNC1)	-
90	<a href="#">Information Mutually Agreed Between Trading Partners</a>	n2+an..30	(FNC1)	INTERNAL
91 to 99	<a href="#">Company Internal Information</a>	n2+an..30	(FNC1)	INTERNAL

### 3.3. GS1 Application Identifiers starting with digit 0

#### 3.3.1. Identification of a Logistic Unit: AI (00)

The Application Identifier (00) indicates that the GS1 Application Identifier data field contains an SSCC (Serial Shipping Container Code). The SSCC is used to identify logistic units (see Section 2.2).

The Extension digit is used to increase the capacity of the Serial Reference within the SSCC. It is assigned by the company that constructs the SSCC. The Extension digit ranges from 0-9.

The GS1 Company Prefix is allocated by GS1 Member Organisations to a system user (see Section 1.5). It makes the SSCC unique worldwide but does not identify the origin of the unit.

The structure and content of the Serial Reference is at the discretion of owner of the GS1 Company Prefix.

The Check Digit is explained in Section 7.10. Its verification, which must be carried out in the application software, ensures that the number is correctly composed.

Figure 3.3.1 - 1

Format of the Element String																		
SSCC (Serial Shipping Container Code)																		
Application Identifier	Extension Digit	GS1 Company Prefix				Serial Reference				Check Digit								
0 0	N <sub>1</sub>	N <sub>2</sub>	N <sub>3</sub>	N <sub>4</sub>	N <sub>5</sub>	N <sub>6</sub>	N <sub>7</sub>	N <sub>8</sub>	N <sub>9</sub>	N <sub>10</sub>	N <sub>11</sub>	N <sub>12</sub>	N <sub>13</sub>	N <sub>14</sub>	N <sub>15</sub>	N <sub>16</sub>	N <sub>17</sub>	N <sub>18</sub>

The data transmitted from the bar code reader means that the identification number of a logistic unit has been captured.

When indicating this Element String in the human readable section of a bar code label, the following Data Title should be used (see also Section 3.2): **SSCC**

#### 3.3.2. Identification of a Fixed Measure Trade Item (GTIN): AI (01)

The Application Identifier (01) indicates that the GS1 Application Identifier data field contains a GTIN. The GTIN is used to identify trade items (see Section 4).

The GTIN for Fixed Measure Trade Items can include a GTIN-12, or GTIN-13 Identification Number or a GTIN-14 Identification Number.

The Check Digit is explained in Section 7.10. Its verification, which must be carried out in the application software, ensures that the number is correctly composed.

Figure 3.3.2 - 1

Format of the Element String	
Application Identifier	Global Trade Item Number (GTIN)
(GTIN-12) 0 1	0 0 N <sub>1</sub> N <sub>2</sub> N <sub>3</sub> N <sub>4</sub> N <sub>5</sub> N <sub>6</sub> N <sub>7</sub> N <sub>8</sub> N <sub>9</sub> N <sub>10</sub> N <sub>11</sub> N <sub>12</sub>
(GTIN-13) 0 1	0 N <sub>1</sub> N <sub>2</sub> N <sub>3</sub> N <sub>4</sub> N <sub>5</sub> N <sub>6</sub> N <sub>7</sub> N <sub>8</sub> N <sub>9</sub> N <sub>10</sub> N <sub>11</sub> N <sub>12</sub> N <sub>13</sub>
(GTIN-14) 0 1	N <sub>1</sub> N <sub>2</sub> N <sub>3</sub> N <sub>4</sub> N <sub>5</sub> N <sub>6</sub> N <sub>7</sub> N <sub>8</sub> N <sub>9</sub> N <sub>10</sub> N <sub>11</sub> N <sub>12</sub> N <sub>13</sub> N <sub>14</sub>

The data transmitted from the bar code reader means that the identification number of a Fixed Measure Trade Item has been captured

When indicating this Element String in the human readable section of a bar code label, the following data title should be used (see also Section 3.2): **GTIN**

### 3.3.3. Identification of a Variable Measure Trade Item (GTIN): AI (01)

The Application Identifier (01) indicates that the GS1 Application Identifier data field contains a GTIN. The GTIN is used to identify trade items (see Section 4).

The GTIN for Variable Measure Trade Items is a special application of the GTIN-14 Data Structure. The digit 9 in the Indicator position indicates that the item identified is a Variable Measure Trade Item.

Unlike GTIN-14s used to identify fixed measure trade items (see Section 2, Identification of Uniform Groupings of Trade Items), this GTIN-14 is not derived from the GTIN (without check digit) of the contained trade items.

The GTIN-14 must be processed in its entirety and not broken down into its constituent elements.

Each standard average measurement grouping must be assigned its own GTIN-14 according to the GTIN Allocation Rules.

The Check Digit is explained in Section 7.10. Its verification, which must be carried out in the application software, ensures that the number is correctly composed.

Figure 3.3.3 – 1

Format of the Element String				
Application Identifier	Global Trade Item Number (GTIN)			
	Indicator	GS1 Company Prefix		
		←		
0 1	9	N <sub>2</sub> N <sub>3</sub> N <sub>4</sub> N <sub>5</sub> N <sub>6</sub> N <sub>7</sub> N <sub>8</sub> N <sub>9</sub> N <sub>10</sub> N <sub>11</sub> N <sub>12</sub> N <sub>13</sub>		N <sub>14</sub>

The data transmitted from the bar code reader means that the GTIN-14 Identification Number of a Variable Measure Trade Item has been captured. To complete the item identification, the variable information must be present at the same time (see 2.1.6 Optional Attributes).

When indicating this Element String in the human readable section of a bar code label, the following Data Title should be used (see also Section 3.2): **GTIN**

### 3.3.4. Identification of Fixed Measure Trade Items Contained in a Logistic Unit: AI (02)

The Application Identifier (02) indicates that the GS1 Application Identifier data field includes the GTIN of the contained trade items. The GTIN is used to identify trade items (see Section 4).

**Note:** This Element String may be used only on a logistic unit that is not itself a trade item and if all trade items that are contained at the same level have the same GTIN.

The GTIN of the trade items contained represents the identification number of the highest level of trade item contained in the logistic unit.

The Check Digit is explained in Section 7.10. Its verification, which must be carried out in the application software, ensures that the number is correctly composed.

Figure 3.3.4 – 1

Format of the Element String		
Application Identifier	GTIN of the Contained Trade Items	Check Digit
0 2	N <sub>1</sub> N <sub>2</sub> N <sub>3</sub> N <sub>4</sub> N <sub>5</sub> N <sub>6</sub> N <sub>7</sub> N <sub>8</sub> N <sub>9</sub> N <sub>10</sub> N <sub>11</sub> N <sub>12</sub> N <sub>13</sub>	N <sub>14</sub>

The data transmitted from the bar code reader means that the identification number of Fixed Measure Trade Items contained in a logistic unit has been captured. It must be processed together with Element String AI (37), which must appear on the same unit (see Section 3.6.5).

When indicating this Element String in the human readable section of a bar code label, the following Data Title should be used (see also Section 3.2): **CONTENT**

### 3.3.5. Identification of Variable Measure Trade Items Contained in a Logistic Unit: AI (02)

The Application Identifier (02) indicates that the GS1 Application Identifier data field includes the GTIN of the contained trade items. Indicator digit 9 is required for a GTIN-14 used for Variable Measure Trade Items.

**Note:** This Element String may be used only on a logistic unit that is not itself a trade item and if all trade items that are contained at the same level have the same GTIN. If the trade items are Variable Measure Trade Items, then this GTIN will be the implied item number that does not appear on the items contained.

The GTIN of the trade items contained represents the identification number of the highest level of items contained in the logistic unit.

The Check Digit is explained in Section 7.10. Its verification, which must be carried out in the application software, ensures that the number is correctly composed.

Figure 3.3.5 – 1

Format of the Element String		
Application Identifier	GTIN of the Contained Trade Item	Check Digit
0 2	9 N <sub>2</sub> N <sub>3</sub> N <sub>4</sub> N <sub>5</sub> N <sub>6</sub> N <sub>7</sub> N <sub>8</sub> N <sub>9</sub> N <sub>10</sub> N <sub>11</sub> N <sub>12</sub> N <sub>13</sub>	N <sub>14</sub>

The data transmitted from the bar code reader means that the GTIN-14 Identification Number of a Variable Measure Trade Item contained in a logistic unit has been captured. It must be processed with Element String AI (37) and a valid trade measure that must appear on the same unit (see Section 3.6.5).

When indicating this Element String in the human readable section of a bar code label, the following Data Title should be used (see also Section 3.2): **CONTENT**

### 3.4. GS1 Application Identifiers starting with digit 1

#### 3.4.1. Batch or Lot Number: AI (10)

The Application Identifier (10) indicates that the GS1 Application Identifier data field contains a batch or lot number. The batch or lot number associates an item with information the manufacturer considers relevant for traceability of the trade item to which the Element String is applied. The data may refer to the trade item itself or to items contained. The number may be, for example, a production lot number, a shift number, a machine number, a time, or an internal production code. The data is alphanumeric and may include all characters contained in Figure 7.12 - 1.

**Note:** The batch or lot number is not part of the unique identification of a trade item.

Figure 3.4.1 - 1

Format of the Element String	
Application Identifier	Batch or Lot Number
1 0	X <sub>1</sub> ————— variable length —————> X <sub>20</sub>

The data transmitted by the bar code reader means that the Element String denoting a batch or lot number has been captured. As it is an attribute of a particular item, the batch or lot number should not be processed on its own, but together with the GTIN of the trade item to which it relates.

When indicating this Element String in the human readable section of a bar code label, the following Data Title should be used (see also Section 3.2): **BATCH/LOT**

#### 3.4.2. Production Date: AI (11)

The Application Identifier (11) indicates that the GS1 Application Identifier data field contains a production date. The production date is the production or assembly date determined by the manufacturer. The date may refer to the trade item itself or to items contained.

The structure is:

- Year: the tens and units of the year (e.g., 2003 = 03), which is mandatory
- Month: the number of the month (e.g., January = 01), which is mandatory
- Day: the number of the day of the relevant month (e.g., second day = 02); if it is not necessary to specify the day, the field must be filled with two zeros

**Note:** This Element String can only specify dates ranging from 49 years in the past to 50 years in the future. Determination of the correct century is explained in Section 7.13.

Figure 3.4.2 - 1

Format of the Element String			
Application Identifier	Production Date		
	Year	Month	Day
1 1	N <sub>1</sub> N <sub>2</sub>	N <sub>3</sub> N <sub>4</sub>	N <sub>5</sub> N <sub>6</sub>

The data transmitted from the bar code reader means that the Element String denoting a production date has been captured. As it is an attribute of a trade item, the production date should not be processed on its own, but together with the GTIN of the trade item to which it relates.

When indicating this Element String in the human readable section of a bar code label, the following Data Title should be used (see also Section 3.2): **PROD DATE**

### 3.4.3. Due Date for Amount on Payment Slip: AI (12)

The Application Identifier (12) indicates that the GS1 Application Identifier data field contains the date by which an invoice should be paid. This data element represents an attribute of a payment slip reference number, AI (8020), and a Global Location Number (GLN) of the invoicing party.

The structure is:

- Year: the tens and units of the year (e.g., 1998 = 98), which is mandatory
- Month: the number of the month (e.g., January = 01), which is mandatory
- Day: the number of the day of the relevant month (e.g., second day = 02); if it is not necessary to specify the day, the field must be filled with two zeros


 **Note:** This Element String can only specify dates ranging from 49 years in the past to 50 years in the future. Determination of the correct century is explained in Section 7.13.

Figure 3.4.3 - 1

Format of the Element String			
Application Identifier	Due Date		
	Year	Month	Day
1 2	N <sub>1</sub> N <sub>2</sub>	N <sub>3</sub> N <sub>4</sub>	N <sub>5</sub> N <sub>6</sub>

The data transmitted from the bar code reader means that a due date has been captured. This data element should only be processed with a payment slip reference number, AI (8020), and a GLN of the invoicing party.

When indicating this Element String in the human readable section of a bar code label, the following Data Title should be used (see also Section 3.2): **DUE DATE**

### 3.4.4. Packaging Date: AI (13)

The Application Identifier (13) indicates that the GS1 Application Identifier data fields contain a packaging date. The packaging date is the date when the goods were packed as determined by the packager. The date may refer to the trade item itself or to items contained.

The structure is:

- Year: the tens and units of the year (e.g., 2003 = 03), which is mandatory
- Month: the number of the month (e.g., January = 01), which is mandatory
- Day: the number of the day of the relevant month (e.g., second day = 02); if it is not necessary to specify the day, the field must be filled with two zeros

- Note:** This Element String can only specify dates ranging from 49 years in the past to 50 years in the future. Determination of the correct century is explained in Section 7.13.

**Figure 3.4.4 - 1**

Format of the Element String			
Application Identifier	Packaging Date		
	Year	Month	Day
1 3	N <sub>1</sub> N <sub>2</sub>	N <sub>3</sub> N <sub>4</sub>	N <sub>5</sub> N <sub>6</sub>

The data transmitted from the bar code reader means that the Element String denoting a packaging date has been captured. As it is an attribute of a trade item, the packaging date should not be processed on its own, but together with the GTIN of the trade item to which it relates.

When indicating this Element String in the human readable section of a bar code label, the following Data Title should be used (see also Section 3.2): **PACK DATE**

### 3.4.5. Best Before Date: AI (15)

The Application Identifier (15) indicates that the GS1 Application Identifier data fields contain a best before date. The best before date indicates the ideal consumption or best effective use date of a product. It is a statement about quality. It is often referred to as a sell by date or a minimum durability date.

The structure is:

- Year: the tens and units of the year (e.g., 2003 = 03), which is mandatory
- Month: the number of the month (e.g., January = 01), which is mandatory
- Day: the number of the day of the relevant month (e.g., second day = 02); if it is not necessary to specify the day, the field must be filled with two zeros

- Note:** This Element String can only specify dates ranging from 49 years in the past to 50 years in the future. Determination of the correct century is explained in Section 7.13.

**Figure 3.4.5 - 1**

Format of the Element String			
Application Identifier	Best Before Date		
	Year	Month	Day
1 5	N <sub>1</sub> N <sub>2</sub>	N <sub>3</sub> N <sub>4</sub>	N <sub>5</sub> N <sub>6</sub>

The data transmitted from the bar code reader means that the Element String denoting best before date has been captured. As it is an attribute of a trade item, the best before date should not be processed on its own, but together with the GTIN of the trade item to which it relates.

When indicating this Element String in the human readable section of a bar code label, the following Data Title should be used (see also Section 3.2): **BEST BEFORE** or **SELL BY**

### 3.4.6. Expiration Date: AI (17)

The Application Identifier (17) indicates that the GS1 Application Identifier data fields contain an expiration date. The expiration date is the date that determines the limit of consumption or use of a product. Its meaning is determined based on the trade item context (e.g., for food, the date will indicate the possibility of a direct health risk resulting from use of the product after the date, for pharmaceutical products, it will indicate the possibility of an indirect health risk resulting from the ineffectiveness of the product after the date). It is often referred to as "use by date" or "maximum durability date."

The structure is:

- Year: the tens and units of the year (e.g., 2003 = 03), which is mandatory
- Month: the number of the month (e.g., January = 01), which is mandatory
- Day: the number of the day of the relevant month (e.g., second day = 02); if it is not necessary to specify the day, the field must be filled with two zeros


 **Note:** This Element String can only specify dates ranging from 49 years in the past to 50 years in the future. Determination of the correct century is explained in Section 7.13.

Figure 3.4.6 - 1

Format of the Element String			
Application Identifier	Expiration Date		
	Year	Month	Day
1 7	N <sub>1</sub> N <sub>2</sub>	N <sub>3</sub> N <sub>4</sub>	N <sub>5</sub> N <sub>6</sub>

The data transmitted from the bar code reader means that the Element String denoting expiration date has been captured. Since the Element String represents an attribute of a trade item, the expiration date should not be processed on its own, but together with the GTIN of the trade item to which it relates.

When indicating this Element String in the human readable section of a bar code label, the following Data Title should be used (see also Section 3.2): **USE BY or EXPIRY**

## 3.5. GS1 Application Identifiers starting with digit 2

### 3.5.1. Product Variant: AI (20)

This Element String may be used to distinguish a variant from the usual item if the variation is not sufficiently significant to require a separate Global Trade Item Number (GTIN) and the variation is relevant to the brand owner and any third party acting on its behalf.

The product variant is only for use by the brand owner and any third party acting on its behalf and not for dealings with any other trading partners. The product variant shall not be used where the variation would trigger the allocation of a different GTIN per the GTIN Allocation Rules.

Although the Element String will not have meaning to all trading partners, the Element String may remain on the item throughout distribution.

Figure 3.5.1 - 1

Format of the Element String	
Application Identifier	Variant Number
2 0	N <sub>1</sub> N <sub>2</sub>

The Application Identifier (20) indicates that the data field contains a variant number.

The variant number must only be assigned by the brand owner. It forms a subsidiary numbering facility that can be used in addition to the item's GTIN and allows the creation of 100 variants of a particular item.

The data transmitted from the bar code reader means that the Element String denoting a product variant has been captured. The product variant must always be decoded and processed together with the GTIN from the same item. Beyond the brand owner and any third party acting on its behalf, it is decoded and ignored.

When indicating this Element String in the human readable section of a bar code label, the following Data Title should be used (see also Section 3.2): **VARIANT**

### 3.5.2. Serial Number: AI (21)

The Application Identifier (21) indicates that the GS1 Application Identifier data field contains a serial number. A serial number is assigned to an entity for its lifetime. When combined with a GTIN, a serial number uniquely identifies an individual item. The serial number field is alphanumeric and may include all characters contained in Figure 7.12 - 1. The manufacturer determines the serial number.

Figure 3.5.2 - 1

Format of the Element String	
Application Identifier	Serial Number
2 1	X <sub>1</sub> _____ variable length → X <sub>20</sub>

The data transmitted from the bar code reader means that the Element String denoting a serial number has been captured. The Element String represents an attribute of a trade item and, therefore, the serial number should not be processed on its own, but together with the identification number of the trade item to which it relates.

When indicating this Element String in the human readable section of a bar code label, the following Data Title should be used (see also Section 3.2): **SERIAL**

### 3.5.3. Secondary Data for Specific Health Industry Products: AI (22)

Not recommended for use (see Section 7.8)

### 3.5.4. Additional Product Identification Assigned by the Manufacturer: AI (240)

The Application Identifier (240) indicates that the GS1 Application Identifier data field contains additional item identification. The purpose of this Element String is to enable identification data other than the Global Trade Item Number (GTIN) to be represented in a GS1 System data carrier. It is a cross-reference to previously used catalogue numbers. The additional item identification is considered

an attribute of the GTIN (e.g., it facilitates migration to the GS1 System during a transitional period). However, it must not be used to replace the GTIN.

The additional item identification field is alphanumeric and may include all characters contained in Figure 7.12 - 1. Its content and structure are at the discretion of the company applying the Element String.

Figure 3.5.4 - 1

Format of the Element String	
Application Identifier	Additional Item Identification
2 4 0	X <sub>1</sub> _____ variable length _____ → X <sub>30</sub>

The data transmitted from the bar code reader means that the Element String denoting an additional item identification has been captured.

When indicating this Element String in the human readable section of a bar code label, the following Data Title should be used (see also Section 3.2): **ADDITIONAL ID**

### 3.5.5. Customer Part Number: AI (241)

The Application Identifier (241) indicates that the GS1 Application Identifier data field contains a customer part number. The purpose of this Element String is to enable identification data other than the Global Trade Item Number (GTIN) to be represented in a GS1 System data carrier. The Element String should only be used between trading partners that are currently using the customer part number for ordering and who have agreed on a timetable to convert to the GTIN for their business purposes. Therefore, the use of the GTIN and the AI (241) on trade items is for transitional use during the conversion. The customer part number must not be used in place of the GTIN.

The customer part number field is alphanumeric and may include all characters contained in Figure 7.12 – 1.

Figure 3.5.5 - 1

Format of the Element String	
Application Identifier	Customer Part Number
2 4 1	X <sub>1</sub> _____ variable length _____ → X <sub>30</sub>

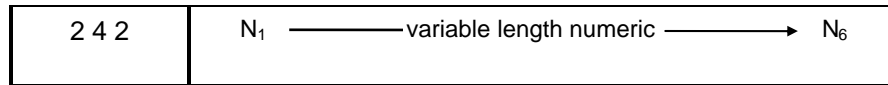
The data transmitted from the bar code reader means that the Element String denoting a customer part number has been captured.

When indicating this Element String in the human readable section of a bar code label, the following Data Title should be used (see also Section 3.2): **CUST. PART NO.**

### 3.5.6. Made-to-Order Variation Number: AI (242)

Figure 3.5.6 - 1

Format of the Element String	
Application Identifier	Made-to-Order Variation Number



The Application Identifier (242) indicates that the data field contains a Made-to-Order Variation Number. The data is variable length numeric up to and including six digits.

The Made-to-Order Variation Number provides the additional data needed to uniquely identify a custom trade item. (See Section 2.6.)

There is a mandatory association of AI 242 with a GTIN-14, Indicator Digit 9. This association indicates that the GTIN-14, Indicator Digit 9 represents a custom trade item when paired with AI 242.

A Made-to-Order Variation Number may not be used with the following GTINs: GTIN-8, GTIN-12, GTIN-13, and GTIN-14 Indicator Digit 1 through 8. The use of a GTIN-14, Indicator Digit 9 and a Made-to-Order Variation Number is only approved for the Maintenance, Repair, and Operation (MRO) industrial supply sector.

The data transmitted by the bar code reader means that the Element String denoting a Made-to-Order Variation Number has been captured. An AI (242) will never appear alone, but always in conjunction with the GTIN-14, Indicator Digit 9.

When indicating this Element String in the human readable section of a bar code label, the following data title should also be used (see also Section 3.2): **MTO Variant**

### 3.5.7. Secondary Serial Number: AI (250)

The Application Identifier (250) indicates that the GS1 Application Identifier data field contains a secondary serial number. While the Element String using AI (21) (see Section 3.5.2) contains the serial number of the trade item, the Element String denoting a secondary serial number represents the serial number of a component of that item. The company applying the Element String determines which component the Element String refers to for a given trade item. The recognition of the meaning of the secondary serial number is accomplished via the GTIN and information provided by the issuer regarding the component to which the secondary serial number refers.

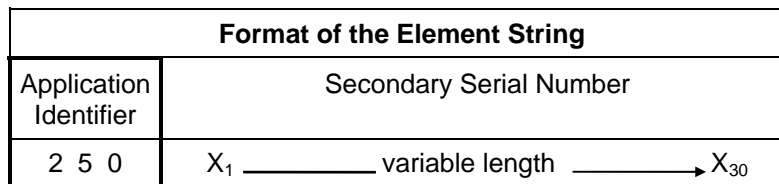
If this Element String is being used, the trade item must be symbol marked with the following Element Strings:

- AI (01): representing the GTIN of the trade item
- AI (21): representing the serial number of the trade item
- AI (250): representing the serial number of a component of the trade item

Only one Element String with AI (250) may be associated with a particular GTIN.

The secondary serial number field is alphanumeric and may include all characters contained in Figure 7.12 – 1. The number and to what component it relates is determined by the issuer.

Figure 3.5.7 - 1



The data transmitted from the bar code reader means that the Element String denoting a secondary serial number has been captured.

When indicating this Element String in the human readable section of a bar code label, the following Data Title should be used (see also Section 3.2): **SECONDARYSERIAL**

**Note:** The actual data title may be specified by the issuer of the data.

### 3.5.8. Reference to Source Entity: AI (251)

The Application Identifier (251) indicates that the GS1 Application Identifier data field consists of a reference to the original item. Reference to source entity is an attribute of a trade item used to refer to the original item from which the trade item was derived. The issuer of the trade item must indicate through other means the source entity to which the data refers.

For example, the original item could be an animal from which a carcass of beef is derived. This Element String would enable reference to the original animal, so that, if the animal was found to be contaminated, all derived products could be isolated. In addition, this Element String could also be used for regulatory compliance when recycling parts from various white goods, such as refrigerators, where it is necessary to refer to the original appliance.

The reference to the source entity field is alphanumeric and may include all characters contained in Figure 7.12 – 1.

Figure 3.5.8 - 1

Format of the Element String	
Application Identifier	Reference to Source Entity
2 5 1	X <sub>1</sub> ————— variable length —————> X <sub>30</sub>

The data transmitted by the bar code reader means that the Element String denoting a reference to source entity has been captured. Since this Element String represents an attribute of a GTIN, the reference to the source entity should not be processed on its own.

When indicating this Element String in the human readable section of a bar code label, the following Data Title should be used (see also Section 3.2): **REF. TO SOURCE**

**Note:** The actual data title may be specified by the issuer of the data.

### 3.5.9. Global Document Type Identifier (GDTI): AI (253)

The Application Identifier (253) indicates that the GS1 Application Identifier data field contains the Global Document Type Identifier (GDTI). The GDTI used to identify a document type with an optional serial number.

The GS1 Company Prefix is the GS1 Company Prefix of the document issuer (see Section 1.5). It makes the number unique worldwide.

The Document Type is assigned by the document issuer.

The Check Digit is explained in Section 7.10. Its verification, which must be carried out in the application software, ensures that the number is correctly composed.

The optional serial component is assigned to a single document for its lifetime. When combined with a GDIT, it uniquely identifies an individual document. The Serial Component field is numeric and may contain up to 17 digits. The issuer of the document determines the serial component.

Figure 3.5.9 - 1

Format of the Element String			
Application Identifier	Global Document Type Identifier (GDTI)		
	GS1 Company Prefix	Document Type	Check Digit
2 5 3	N <sub>1</sub> N <sub>2</sub> N <sub>3</sub> N <sub>4</sub> N <sub>5</sub> N <sub>6</sub> N <sub>7</sub> N <sub>8</sub> N <sub>9</sub> N <sub>10</sub> N <sub>11</sub> N <sub>12</sub>		N <sub>13</sub>
	Serial Component (Optional)		N <sub>1</sub> — variable → N <sub>17</sub>

The data transmitted from the bar code reader means that the GDTI has been captured. It may be processed according to the particular application requirements.

When indicating this Element String in the human readable section of a bar code label, the following Data Title should be used (see also Section 3.2): **DOC. ID**

### 3.5.10. GLN Extension Component: AI (254)

The Application Identifier (254) indicates that the data field contains an extension component of a Global Location Number (GLN). The use of AI (254) is optional, but when used it must appear in conjunction with AI (414), identification of a physical location.

The GS1 Company Prefix owner determines the extension component. Once determined, it is unchanged for the life of the associated GLN.

The GLN Extension Component field is alphanumeric and may include all characters contained in Figure 7.12 – 1.

Figure 3.5.10 - 1

Format of the Element String	
Application Identifier	GLN Extension Component
254	X <sub>1</sub> — variable length —→ X <sub>20</sub>

The data transmitted from the reader means that the Element String denoting an extension component of a GLN has been captured. The Element String represents an attribute of a GLN, and therefore, the extension component should not be processed alone, but with the identification number of the GLN to which it relates.

When indicating this Element String in the human readable section of a bar code label, the following Data Title should be used (see also Section 3.2): **GLN EXTENSION**

## 3.6. GS1 Application Identifiers starting with digit 3

### 3.6.1. Variable Count: AI (30)

The Application Identifier (30) indicates that the GS1 Application Identifier data field contains the number of items contained in a Variable Measure Trade Item. This Element String is used to complete the identification of a Variable Measure Trade Item and, therefore, should never be applied in isolation.

The Count of Items field represents the quantity contained in the respective trade item. It is of variable length and may have up to eight digits.

**Note:** This Element String must not be used to indicate the contained quantity of a Fixed Measure Trade Item. However, if this Element String appears on a Fixed Measure Trade Item (in error) it should not invalidate the item identification but should be treated as redundant data.

**Figure 3.6.1 – 1**

Format of the Element String	
Application Identifier	Count of Items
3 0	N <sub>1</sub> _____ variable length → N <sub>8</sub>

The data transmitted from the bar code reader means that the quantity (count of items), which can be considered part of the identification of a Variable Measure Trade Item, has been captured. The variable count must be processed with the Global Trade Item Number (GTIN) of the trade item to which it relates.

When indicating this Element String in the human readable section of a bar code label, the following Data Title should be used (see also Section 3.2): **VAR. COUNT**

### 3.6.2. Trade Measures: AIs (31nn, 32nn, 35nn, 36nn)

The Application Identifiers (digits A1 to A3 – see figure below) indicate that the GS1 Application Identifier data field contains the quantity or dimension of a Variable Measure Trade Item. It also denotes the unit of measure. These Element Strings are used to complete the identification of a Variable Measure Trade Item. They contain information such as the weight, size, volume, or dimension of a Variable Measure Trade Item and, therefore, should never be applied alone. Several Element Strings are possible if the variables required are dimensions or weights expressed in kilograms and pounds.

The Application Identifier digit A4 indicates the implied decimal point position, where, for example, the digit 0 means that there is no decimal point, and the digit 1 means that the decimal point is between N5 and N6.

The Applicable Value field contains the variable measure that applies to the respective trade item.

**Figure 3.6.2 - 1**

Format of the Element String	
Application Identifier	Applicable Value
A <sub>1</sub> A <sub>2</sub> A <sub>3</sub> A <sub>4</sub>	N <sub>1</sub> N <sub>2</sub> N <sub>3</sub> N <sub>4</sub> N <sub>5</sub> N <sub>6</sub>

The Application Identifiers used with this Element String are shown in the Figure below.

**Note:** Other values of AI (3nnn) specify gross measures and logistic measures.

Figure 3.6.2 - 2

A <sub>1</sub>	A <sub>2</sub>	A <sub>3</sub>	Trade Measure	Unit of Measure
3	1	0	Net weight	Kilograms
3	1	1	Length or first dimension	Metres
3	1	2	Width, diameter, or second dimension	Metres
3	1	3	Depth, thickness, height, or third dimension	Metres
3	1	4	Area	Square metres
3	1	5	Net volume	Litres
3	1	6	Net volume	Cubic metres
3	2	0	Net weight	Pounds
3	2	1	Length or first dimension	Inches
3	2	2	Length or first dimension	Feet
3	2	3	Length or first dimension	Yards
3	2	4	Width, diameter, or second dimension	Inches
3	2	5	Width, diameter, or second dimension	Feet
3	2	6	Width, diameter, or second dimension	Yards
3	2	7	Depth, thickness, height, or third dimension	Inches
3	2	8	Depth, thickness, height, or third dimension	Feet
3	2	9	Depth, thickness, height, or third dimension	Yards
3	5	0	Area	Square inches
3	5	1	Area	Square feet
3	5	2	Area	Square yards
3	5	6	Net weight	Troy ounces
3	5	7	Net weight (or volume)	Ounces
3	6	0	Net volume	Quarts
3	6	1	Net volume	Gallons (U.S.)
3	6	4	Net volume	Cubic inches
3	6	5	Net volume	Cubic feet
3	6	6	Net volume	Cubic yards

The data transmitted from the bar code reader means that the quantity, which can be considered part of the identification of a Variable Measure Trade Item, has been captured. It must be processed with the Global Trade Item Number (GTIN) of the trade item to which it relates.

When indicating this Element String in the human readable section of a bar code label, the Data Title in Section [3.2](#) should be used.

### 3.6.3. Logistic Measures: AIs (33nn, 34nn, 35nn, 36nn)

The Application Identifiers (A1 to A3 see Figure below) indicate that the GS1 Application Identifier data field contains the logistic quantity or dimension of a logistic unit or a Variable Measure Trade Item. They also denote the unit of measure.

**Note:** The GS1 System provides standards for logistic weights and measures in metric and other units of measure. In principle, a particular logistic measure should be applied in only one unit of measure on a given logistic unit. However, application of the same attribute in several units of measure does not impede the correct processing of the transmitted data.

The Application Identifier digit in field A4 indicates the implied decimal point position, where, for example, the digit 0 means that there is no decimal point, and the digit 1 means that the decimal point is between N5 and N6.

The Applicable Value field represents the measures of the respective unit.

**Figure 3.6.3 - 1**

Format of the Element String									
Application Identifier				Applicable Value					
A <sub>1</sub>	A <sub>2</sub>	A <sub>3</sub>	A <sub>4</sub>	N <sub>1</sub>	N <sub>2</sub>	N <sub>3</sub>	N <sub>4</sub>	N <sub>5</sub>	N <sub>6</sub>

The Application Identifiers used with this Element String are shown in Figure below

**Figure 3.6.3 – 2**

A <sub>1</sub>	A <sub>2</sub>	A <sub>3</sub>	Definition of Logistic Measures	Unit of Measure
3	3	0	Logistic weight	Kilograms
3	3	1	Length or first dimension	Metres
3	3	2	Width, diameter, or second dimension	Metres
3	3	3	Depth, thickness, height, or third dimension	Metres
3	3	4	Area	Square metres
3	3	5	Logistic volume	Litres
3	3	6	Logistic volume	Cubic metres
3	4	0	Logistic weight	Pounds
3	4	1	Length or first dimension	Inches
3	4	2	Length or first dimension	Feet
3	4	3	Length or first dimension	Yards
3	4	4	Width, diameter, or second dimension	Inches
3	4	5	Width, diameter, or second dimension	Feet
3	4	6	Width, diameter, or second dimension	Yards
3	4	7	Depth, thickness, height, or third dimension	Inches
3	4	8	Depth, thickness, height, or third dimension	Feet
3	4	9	Depth, thickness, height, or third dimension	Yards
3	5	3	Area	Square inches
3	5	4	Area	Square feet
3	5	5	Area	Square yards
3	6	2	Logistic volume	Quarts
3	6	3	Logistic volume	Gallons (U.S.)
3	6	7	Logistic volume	Cubic inches

A <sub>1</sub>	A <sub>2</sub>	A <sub>3</sub>	Definition of Logistic Measures	Unit of Measure
3	6	8	Logistic volume	Cubic feet
3	6	9	Logistic volume	Cubic yards

The data transmitted from the bar code reader means that a logistic measure has been captured. It must be processed with the SSCC (Serial Shipping Container Code) or the Global Trade Item Number (GTIN) of the Variable Measure Trade Item appearing on the same unit.

When indicating this Element String in the human readable section of a bar code label, the Data Title in Section 3.2 should be used.

### 3.6.4. Kilograms Per Square Metre: AI (337n)

The Application Identifier (337) indicates that the GS1 Application Identifier data field contains the kilograms per square metre of a particular trade item.

The Application Identifier digit shown as “n” indicates the implied decimal point position, where, for example, the digit 0 means that there is no decimal point, and the digit 1 means that the decimal point is between N5 and N6.

The Kilograms Per Square Metre field contains the weight per area of the respective trade item. The unit of measure is kilograms.

Figure 3.6.4 - 1

Format of the Element String						
Application Identifier	Kilograms Per Square Metre					
3 3 7 n	N <sub>1</sub>	N <sub>2</sub>	N <sub>3</sub>	N <sub>4</sub>	N <sub>5</sub>	N <sub>6</sub>

The data transmitted from the bar code reader means that the Element String denoting kilograms per square metre has been captured. Since the Element String represents an attribute of a trade item, it should not be processed on its own, but together with the Global Trade Item Number (GTIN) of the trade item to which it relates.

When indicating this Element String in the human readable section of a bar code label, the following Data Title should be used (see also Section 3.2): **KG PER m<sup>2</sup>**

### 3.6.5. Count of Trade Items Contained in a Logistic Unit: AI (37)

The Application Identifier (37) indicates that the GS1 Application Identifier data field contains the number of trade items contained in a logistic unit. This Element String is a mandatory completion of AI (02) described in Sections 3.3.4 and 3.3.5.

The Count of Trade Items field contains the number of trade items contained in the respective logistic unit. This information refers to the identification number of the contained trade items.

Figure 3.6.5 – 1

Format of the Element String	
Application Identifier	Count of Trade Items
3 7	N <sub>1</sub> ————— variable length —————> N <sub>8</sub>

The data transmitted from the bar code reader means that the number of trade items contained in a logistic unit has been captured. This number must be processed with the identification number represented in AI (02) (see Sections 3.3.4 and 3.3.5) appearing on the same logistic unit.

When indicating this Element String in the human readable section of a bar code label, the following Data Title should be used (see also Section 3.2): **COUNT**

### 3.6.6. Amount Payable - Single Monetary Area: AI (390n)

The Application Identifier (390) indicates that the GS1 Application Identifier data field contains the amount payable of a payment slip.

The Application Identifier digit shown as “n” indicates the implied decimal point position, where the digit 0 means that there is no decimal point, and the digit 1 means that the decimal point is before the last position of the amount payable. See examples in Figure below

The applicable amount payable contains the sum to be paid with the respective payment slip.

Figure 3.6.6 - 1

Format of the Element String	
Application Identifier	Applicable Amount Payable
3 9 0 n	N <sub>1</sub> _____ variable length _____ N <sub>15</sub>

**Note:** To aid unambiguous processing, AI (391n), described in Section 3.6.7, should be used to indicate the currency in which the amount is expressed.

The Figure below shows examples of the decimal point indication.

Figure 3.6.6 - 2

Application Identifier	Encoded Value	Actual Value
3 9 0 2	1 2 3 4 5 6 7	1 2 3 4 5 . 6 7
3 9 0 1	1 2 3 4 5 6 7	1 2 3 4 5 6 . 7 0
3 9 0 0	1 2 3 4 5	1 2 3 4 5 . 0 0

The data string transmitted from the bar code reader means that the amount payable of a payment slip has been captured. Since this Element String represents an attribute of a payment slip reference number and a Global Location Number (GLN) of the invoicing party, the amount payable should not be processed on its own.

When indicating this Element String in the human readable section of a bar code label, the following Data Title should be used (see also Section 3.2): **AMOUNT**

### 3.6.7. Amount Payable and ISO Currency Code: AI (391n)

The Application Identifier (391) indicates that the GS1 Application Identifier data fields consist of an ISO currency code and an applicable amount payable.

The Application Identifier digit shown as “n” indicates the implied decimal point position in the Applicable Amount Payable field, where the digit 0 means that there is no decimal point, and the digit 1 means that the decimal point is before the last position of the amount payable. See examples in the Figure below.

The ISO country code field contains the three-digit currency number of the numerical international standard ISO 4217 and indicates the currency in which the amount payable is expressed.

The applicable amount payable contains the sum to be paid with the respective payment slip.

Figure 3.6.7 - 1

Format of the Element String		
Application Identifier	ISO Currency Code	Applicable Amount Payable
3 9 1 n	N <sub>1</sub> N <sub>2</sub> N <sub>3</sub>	N <sub>4</sub> _____ variable length _____ N <sub>18</sub>

Figure 3.6.7 – 2 shows examples of the decimal point indication.

Figure 3.6.7 - 2

Application Identifier	ISO Currency Code	Encoded Value	Actual Value
3 9 1 2	7 1 0 <sup>*</sup>	1 2 3 0	1 2 . 3 0
3 9 1 1	7 1 0 <sup>*</sup>	1 2 3 0	1 2 3 . 0 0
3 9 1 0	9 7 8 <sup>**</sup>	1 2 3	1 2 3 . 0 0

\* South African Rand  
 \*\*Euro

The data string transmitted from the bar code reader means that the amount payable has been captured. Since this Element String represents an attribute of a payment slip reference number and a Global Location Number (GLN) of the invoicing party, it should not be processed on its own.

When indicating this Element String in the human readable section of a bar code label, the following Data Title should be used (see also Section 3.2): **AMOUNT**

### 3.6.8. Amount Payable for a Variable Measure Trade Item – Single Monetary Area: AI (392n)

The Application Identifier (392) indicates that the GS1 Application Identifier data field contains the amount payable for a Variable Measure Trade Item.

The amount payable refers to an item identified by the Global Trade Item Number (GTIN) of a Variable Measure Trade Item and is expressed in local currency. This AI is an attribute of the GTIN and is always used in conjunction with it.

The Application Identifier digit shown as “n” indicates the implied decimal point position, where the digit 0 means that there is no decimal point, and the digit 1 means that the decimal point is before the last position of the amount payable. See examples in the Figure below.

The Applicable Amount Payable field contains the total to be paid for the Variable Measure Trade Item.

Figure 3.6.8 - 1

Format of the Element String	
Application Identifier	Applicable Amount Payable
3 9 2 n	N <sub>1</sub> _____ variable length _____ N <sub>15</sub>

**Figure 3.6.7 - 2**

Application Identifier	Encoded Value	Actual Value
3 9 2 2	1 2 3 4 5 6 7	1 2 3 4 5 . 6 7
3 9 2 1	1 2 3 4 5 6 7	1 2 3 4 5 6 . 7 0
3 9 2 0	1 2 3 4 5	1 2 3 4 5 . 0 0

The data transmitted by the bar code reader means that the Element String denoting the amount payable of a Variable Measure Trade Item has been captured. Since this Element String represents an attribute of a GTIN, the amount payable should not be processed on its own.

When indicating this Element String in the human readable section of a bar code label, the following Data Title should be used (see Section 3.2): **PRICE**

### 3.6.9. Amount Payable for a Variable Measure Trade Item and ISO Currency Code: AI (393n)

The Application Identifier (393) indicates that the GS1 Application Identifier data field consists of an ISO currency code and an applicable amount payable. The amount payable refers to an item identified with the Global Trade Item Number (GTIN) of a Variable Measure Trade Item and is expressed in the indicated currency. This AI is an attribute of the GTIN and is always expressed in conjunction with it.

The Application Identifier digit shown as “n” indicates the implied decimal point in the Applicable Amount Payable Field, where the digit 0 means that there is no decimal point, and the digit 1 means that the decimal point is before the last position of the amount payable. See examples in the Figure below.

The ISO currency code field contains the three-digit currency number of the numerical international standard ISO/IEC 4217 and indicates the currency in which the amount payable is expressed.

The Applicable Amount Payable field contains the sum to be paid for the Variable Measure Trade Item.

**Figure 3.6.9 - 1**

Format of the Element String		
Application Identifier	ISO Currency Code	Applicable Amount Payable
3 9 3 n	N <sub>1</sub> N <sub>2</sub> N <sub>3</sub>	N <sub>4</sub> _____ variable length → N <sub>18</sub>

**Figure 3.6.9 - 2**

Application Identifier	ISO Currency Code	Encoded Value	Actual Value
3 9 3 2	7 1 0*	1 2 3 0	1 2 . 3 0
3 9 3 1	7 1 0*	1 2 3 0	1 2 3 . 0 0
3 9 3 0	9 7 8**	1 2 3	1 2 3 . 0 0

\* South African

\*\* Euro

The data transmitted by the bar code reader means that the Element String denoting amount payable of a Variable Measure Trade Item has been captured. Since this Element String represents an attribute of a GTIN, the amount payable should not be processed on its own.

When indicating this Element String in the human readable section of a bar code label, the following Data Title should be used (see also Section 3.2): **PRICE**

### 3.7. GS1 Application Identifiers starting with digit 4

#### 3.7.1. Customer's Purchase Order Number: AI (400)

The Application Identifier (400) indicates that the GS1 Application Identifier data field contains the customer's purchase order number, restricted for use between two trading partners.

The Customer's Purchase Order Number field is alphanumeric and may include all characters contained in Figure 7.12 – 1. It contains the number of the purchase order assigned by the company that issued the order. The composition and content of the order number is left to the discretion of the customer. For example, the purchase order number may include release and line numbers.

Figure 3.7.1 - 1

Format of the Element String	
Application Identifier	Customer's Purchase Order Number
4 0 0	X <sub>1</sub> ← variable length → X <sub>30</sub>

The data transmitted by the bar code reader means that the Element String denoting a customer's purchase order number has been captured. It may be processed as stand-alone information where applicable or processed with the identification data of the same unit.

**Warning:** This Element String must be removed from the unit before the unit leaves the premises of the customer.

When indicating this Element String in the human readable section of a bar code label, the following Data Title should be used (see also Section 3.2): **ORDER NUMBER**

#### 3.7.2. Consignment Number: AI (401)

The Application Identifier (401) indicates that the GS1 Application Identifier data field contains a consignment number. The consignment number identifies a logical grouping of goods (one or more physical entities) that has been consigned to a freight forwarder and is intended to be transported as a whole. The consignment number must be allocated by a freight forwarder (or a carrier acting as a freight forwarder) or a consignor, but only if prior agreement of the freight forwarder is given. Typically AI (401) encodes a House Way Bill (HWB) Number.

According the Multi Industry Scenario for Transport (MIST), a freight forwarder is a party that arranges the carriage of goods, including connected services and/or associated formalities, on behalf of a shipper or consignee. A carrier is a party that undertakes the transportation of goods from one point to another. A consignor is the party that sends the goods.

The consignment number is composed of the GS1 Company Prefix of the carrier and the actual consignment information. The structure of the consignment information following the GS1 Company Prefix is left to the discretion of the user of the Element String. It may contain all characters contained in Figure 7.12 - 1.

Figure 3.7.2 - 1

Format of the Element String	
Application Identifier	Consignment Number
	<div style="display: flex; justify-content: space-between;"> <span>GS1 Company Prefix</span> <span>Consignment Information</span> </div> <div style="display: flex; justify-content: space-between; margin-top: 5px;"> <span>→</span> <span>→</span> </div>
4 0 1	$N_1 \dots N_i \quad X_{i+1} \dots \text{variable length} \quad X_j \text{ (j<=30)}$

The data transmitted by the bar code reader means that the Element String denoting a consignment number has been captured. The consignment number may be processed as stand-alone information where applicable or with other identification data appearing on the same unit.

**Note:** If a new consignment is created, previously consignment number bar code symbols must be removed from the physical units.

When indicating this Element String in the human readable section of a bar code label, the following Data Title should be used (see also Section 3.2): **CONSIGNMENT**

### 3.7.3. Shipment Identification Number: AI (402)

The Application Identifier (402) indicates that the data field contains a shipment identification number.

The shipment identification number (bill of lading) is a number assigned by a consignor. It provides a globally unique number that identifies a logical grouping of physical units for the purpose of a transport shipment. It may be used by all parties in the transport chain as a communication reference. For example, it could be used as a shipment reference and/or a consignor's loading list in Electronic Data Interchange (EDI) messages.

The GS1 Company Prefix in this Element String is the GS1 Company Prefix of the consignor (see Section 1.2).

The shipper reference is assigned by the consignor. It should be sequentially allocated.

The Check Digit is explained in Section 7.10. Its verification, which must be carried out in the application software, ensures that the number is correctly composed.

Figure 3.7.3 - 1

Format of the Element String	
Application Identifier	Shipment Identification Number
	<div style="display: flex; justify-content: space-between;"> <span>GS1 Company Prefix</span> <span>Shipper Reference</span> <span>Check Digit</span> </div> <div style="display: flex; justify-content: space-between; margin-top: 5px;"> <span>→</span> <span>←</span> <span></span> </div>
4 0 2	$N_1 \ N_2 \ N_3 \ N_4 \ N_5 \ N_6 \ N_7 \ N_8 \ N_9 \ N_{10} \ N_{11} \ N_{12} \ N_{13} \ N_{14} \ N_{15} \ N_{16} \ N_{17}$

The data transmitted by the bar code reader means that the Element String denoting a shipment identification number has been captured. The shipment identification number may be processed as stand-alone information where applicable or with other identification data appearing on the same unit.

When indicating this Element String in the human readable section of a bar code label, the following Data Title should be used (see also Section 3.2): **SHIPMENT NO.**

### 3.7.4. Routing Code: AI (403)

The Application Identifier (403) indicates that the GS1 Application Identifier data field contains a routing code. The routing code is assigned by the parcel carrier and is an attribute of the SSCC (Serial Shipping Container Code). It is intended to provide a migration path to the adoption of a yet-to-be-defined international, multi-modal solution. The routing code must not be used to encode information for which other Element Strings have been created (such as a ship to postal code).

The routing code field is alphanumeric and may include all characters contained in Figure 7.12 - 1. Its content and structure are at the discretion of the parcel carrier issuing the code. If parcel carriers wish to enter co-operative agreements with other parcel carriers, then a mutually agreed indicator is required to designate the structure of the routing code.

Figure 3.7.4 - 1

Format of the Element String	
Application Identifier	Routing Code
4 0 3	X <sub>1</sub> ————— variable length —————> X <sub>30</sub>

The data transmitted from the bar code reader means that the Element String denoting a routing code has been captured. The routing code must be processed with the SSCC appearing on the same unit.

When indicating this Element String in the human readable section of a bar code label, the following Data Title should be used (see also Section 3.2): **ROUTE**

### 3.7.5. Ship to - Deliver to Global Location Number: AI (410)

The Application Identifier (410) indicates that the GS1 Application Identifier data field contains the Global Location Number (GLN) of the consignee. The GLN is used to identify physical locations or legal entities (see Section 2.4).

The GS1 Company Prefix is the GS1 Company Prefix of the addressee (see Section 1.5). It makes the number unique worldwide.

The Location Reference is assigned by the addressee's company.

The Check Digit is explained in Section 7.10. Its verification, which must be carried out in the application software, ensures that the number is correctly composed.

Figure 3.7.5 - 1

Format of the Element String				
Application Identifier	GS1 Company Prefix		Location Reference	Check Digit
4 1 0	N <sub>1</sub> N <sub>2</sub> N <sub>3</sub> N <sub>4</sub> N <sub>5</sub> N <sub>6</sub> N <sub>7</sub> N <sub>8</sub> N <sub>9</sub> N <sub>10</sub> N <sub>11</sub> N <sub>12</sub>			N <sub>13</sub>

The data transmitted from the bar code reader means that the GLN of the consignee of a physical item has been captured. The GLN may be processed independently or together with related identifications.

When indicating this Element String in the human readable section of a bar code label, the following Data Title should be used (see also Section 3.2): **SHIP TO LOC**

### 3.7.6. Bill to - Invoice to Global Location Number: AI (411)

The Application Identifier (411) indicates that the GS1 Application Identifier data field contains the Global Location Number (GLN) of the addressee of an invoice. The GLN is used to identify physical locations or legal entities (see Section 2.4).

The GS1 Company Prefix is the GS1 Company Prefix of the addressee (see Section 1.5). It makes the number unique worldwide.

The Location Reference is assigned by the addressee's company.

The Check Digit is explained in Section 7.10. Its verification, which must be carried out in the application software, ensures that the number is correctly composed.

Figure 3.7.6 - 1

Format of the Element String													
Application Identifier	GS1 Company Prefix						Location Reference						Check Digit
4 1 1	N <sub>1</sub>	N <sub>2</sub>	N <sub>3</sub>	N <sub>4</sub>	N <sub>5</sub>	N <sub>6</sub>	N <sub>7</sub>	N <sub>8</sub>	N <sub>9</sub>	N <sub>10</sub>	N <sub>11</sub>	N <sub>12</sub>	N <sub>13</sub>

The data transmitted from the bar code reader means that the GLN of the addressee of an invoice has been captured. The GLN may be processed independently or together with related identifications.

When indicating this Element String in the human readable section of a bar code label, the following Data Title should be used (see also Section 3.2): **BILL TO**

### 3.7.7. Purchased from Global Location Number: AI (412)

The Application Identifier (412) indicates that the GS1 Application Identifier data field contains the Global Location Number (GLN) of the company from which the respective trade item has been purchased. The GLN is used to identify physical locations or legal entities (see Section 2.4).

The GS1 Company Prefix is the GS1 Company Prefix of the supplier (see Section 1.5). It makes the number unique worldwide.

The Location Reference is assigned by the company supplying the trade item.

The Check Digit is explained in Section 7.10. Its verification, which must be carried out in the application software, ensures that the number is correctly composed.

Figure 3.7.7 - 1

Format of the Element String													
Application Identifier	GS1 Company Prefix						Location Reference						Check Digit
4 1 2	N <sub>1</sub>	N <sub>2</sub>	N <sub>3</sub>	N <sub>4</sub>	N <sub>5</sub>	N <sub>6</sub>	N <sub>7</sub>	N <sub>8</sub>	N <sub>9</sub>	N <sub>10</sub>	N <sub>11</sub>	N <sub>12</sub>	N <sub>13</sub>

The data transmitted from the bar code reader means that the GLN of the company that supplied the trade item has been captured. The GLN may be processed independently or together with related identifications.

When indicating this Element String in the human readable section of a bar code label the following Data Title should be used (see also Section 3.2): **PURCHASE FROM**

### 3.7.8. Ship for - Deliver for - Forward to Global Location Number: AI (413)

The Application Identifier (413) indicates that the GS1 Application Identifier data field contains the Global Location Number (GLN) of the internal or subsequent final destination. The GLN is used to identify physical locations or legal entities (see Section 2.4).

The GS1 Company Prefix is the GS1 Company Prefix of the final recipient (see Section 1.5). It makes the number unique worldwide.

The Location Reference is assigned by the final recipient's company.

The Check Digit is explained in Section 7.10. Its verification, which must be carried out in the application software, ensures that the number is correctly composed.

**Note:** This Element String is for the internal use of the consignee and is not to be used by the carrier.

Figure 3.7.8 - 1

Format of the Element String													
Application Identifier	GS1 Company Prefix						Location Reference						Check Digit
4 1 3	N <sub>1</sub>	N <sub>2</sub>	N <sub>3</sub>	N <sub>4</sub>	N <sub>5</sub>	N <sub>6</sub>	N <sub>7</sub>	N <sub>8</sub>	N <sub>9</sub>	N <sub>10</sub>	N <sub>11</sub>	N <sub>12</sub>	N <sub>13</sub>

The data transmitted from the bar code reader means that the GLN of the final recipient of a physical item has been captured. The GLN may be processed independently or together with related identifications.

When indicating this Element String in the human readable section of a bar code label, the following Data Title should be used (see also Section 3.2): **SHIP FOR LOC**

### 3.7.9. Identification of a Physical Location - Global Location Number: AI (414)

The Application Identifier (414) indicates that the GS1 Application Identifier data field contains the Global Location Number (GLN) of a physical location (see Section 2.4).

The GS1 Company Prefix is the prefix of the holder of the location (see Section 1.5). It makes the number unique worldwide.

The Location Reference is assigned by the owner or user of the physical location.

The Check Digit is explained in Section 7.10. Its verification, which must be carried out in the application software, ensures that the number is correctly composed.

Figure 3.7.9 - 1

Format of the Element String													
Application Identifier	GS1 Company Prefix						Location Reference						Check Digit
4 1 4	N <sub>1</sub>	N <sub>2</sub>	N <sub>3</sub>	N <sub>4</sub>	N <sub>5</sub>	N <sub>6</sub>	N <sub>7</sub>	N <sub>8</sub>	N <sub>9</sub>	N <sub>10</sub>	N <sub>11</sub>	N <sub>12</sub>	N <sub>13</sub>

The data transmitted from the bar code reader means that the GLN of a physical location has been captured from the location itself. The GLN may be processed independently or together with related identifications.

When indicating this Element String in the human readable section of a bar code label, the following Data Title should be used (see also Section 3.2): **LOC NO.**

### 3.7.10. Global Location Number of the Invoicing Party: AI (415)

The Application Identifier (415) indicates that the GS1 Application Identifier data field contains the Global Location Number (GLN) of the invoicing party.

The GS1 Company Prefix is the GS1 Company Prefix of the invoicing party (see Section 1.5). It makes the number unique worldwide.

The Location Reference is assigned by the invoicing party.

The Check Digit is explained in Section 7.10. Its verification, which must be carried out in the application software, ensures that the number is correctly composed.

**Note:** This Element String is mandatory on a payment slip. Together with the payment slip reference number, AI (8020), it uniquely identifies a payment slip.

Figure 3.7.10 - 1

Format of the Element String													
Application Identifier	GS1 Company Prefix						Location Reference						Check Digit
4 1 5	N <sub>1</sub>	N <sub>2</sub>	N <sub>3</sub>	N <sub>4</sub>	N <sub>5</sub>	N <sub>6</sub>	N <sub>7</sub>	N <sub>8</sub>	N <sub>9</sub>	N <sub>10</sub>	N <sub>11</sub>	N <sub>12</sub>	N <sub>13</sub>

The data transmitted from the bar code reader means that the GLN of the invoicing party has been captured. The GLN must be processed together with the payment slip reference number, AI (8020), on the same payment slip.

When indicating this Element String in the human readable section of a bar code label, the following Data Title should be used (see also Section 3.2): **PAY TO**

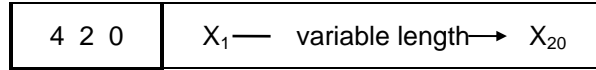
### 3.7.11. Ship to - Deliver to Postal Code within a Single Postal Authority: AI (420)

The Application Identifier (420) indicates that the GS1 Application Identifier data field contains the postal code of the addressee (national format).

The postal code field contains the postal code of the addressee as defined by the appropriate postal authority. It is left justified and must not contain any fill characters.

Figure 3.7.11 - 1

Format of the Element String	
Application Identifier	Postal Code



The data transmitted from the bar code reader means that the national version of a postal code of the addressee of the consignment has been captured. The postal code is normally processed independently.

When indicating this Element String in the human readable section of a bar code label, the following Data Title should be used (see also Section 3.2): **SHIP TO POST**

### 3.7.12. Ship to - Deliver to Postal Code with Three-Digit ISO Country Code: AI (421)

The Application Identifier (421) indicates that the GS1 Application Identifier data field contains the postal code of the addressee (international format).

The ISO country code field contains the three-digit country number of the numerical international standard ISO 3166.

The national postal code field, which follows the three-digit ISO country code, contains the postal code of the addressee as defined by the appropriate postal authority. It is left justified and must not contain any fill characters.

Figure 3.7.12 - 1

Format of the Element String		
Application Identifier	ISO Country Code	Postal Code
4 2 1	N <sub>1</sub> N <sub>2</sub> N <sub>3</sub>	X <sub>4</sub> — variable length → X <sub>12</sub>

The data transmitted from the bar code reader means that the international version of a postal code of the addressee of the consignment has been captured. The postal code is normally processed independently.

When indicating this Element String in the human readable section of a bar code label, the following Data Title should be used (see also Section 3.2): **SHIP TO POST**

### 3.7.13. Country of Origin of a Trade Item: AI (422)

The Application Identifier (422) indicates that the GS1 Application Identifier data field contains the ISO country code of the country of origin of the trade item.

The ISO country code field contains the three-digit country number of the numerical international standard ISO 3166 that is the country of origin.

**Note:** The country of origin is normally the country in which the trade item has been produced or manufactured. However, due to a wide range of definitions for country of origin, which were created for different purposes, it is the manufacturer's responsibility to assign the correct country of origin.

Figure 3.7.13 - 1

Format of the Element String			
Application Identifier	ISO Country Code		
4 2 2	N <sub>1</sub>	N <sub>2</sub>	N <sub>3</sub>

The data transmitted from the bar code reader means that the ISO country code denoting the country of origin of the respective trade item has been captured.

When indicating this Element String in the human readable section of a bar code label, the following Data Title should be used (see also Section 3.2): **ORIGIN**

### 3.7.14. Country of Initial Processing: AI (423)

The Application Identifier (423) indicates that the GS1 Application Identifier data field contains the ISO country code(s) of the country or countries of initial processing of the trade item.

The ISO country code field contains the three-digit country code(s) from the numerical international standard ISO 3166 that indicates the country or countries of initial processing.

- Note:** The country of initial processing is normally the country in which the trade item has been produced or manufactured. However, in certain applications, such as livestock fattening, the country of initial processing may include up to five different countries, all of which should be indicated. It is the responsibility of the supplier to allocate the correct country code(s).

Figure 3.7.14 - 1

Format of the Element String			
Application Identifier	ISO Country Code(s)		
4 2 3	N <sub>1</sub>	N <sub>2</sub>	N <sub>3</sub> ... N <sub>15</sub>

The data transmitted from the bar code reader means that the ISO country code(s) denoting the country or countries of initial processing of the respective trade item has been captured.

When indicating this Element String in the human readable section of a bar code label, the following Data Title should be used (see also Section 3.2): **COUNTRY – INITIAL PROCESS**

### 3.7.15. Country of Processing: AI (424)

The Application Identifier (424) indicates that the GS1 Application Identifier data field contains the ISO country code of the country of processing of the trade item.

The ISO country code field contains the three-digit country code of the numerical international standard ISO 3166 that is the country of processing.

- Note:** It is the responsibility of the processor of the trade item to allocate the correct country code.

Figure 3.7.15 - 1

Format of the Element String
------------------------------

Application Identifier	ISO Country Code
4 2 4	N <sub>1</sub> N <sub>2</sub> N <sub>3</sub>

The data transmitted from the bar code reader means that the ISO country code denoting the country of processing of the respective trade item has been captured.

When indicating this Element String in the human readable section of a bar code label, the following Data Title should be used (see also Section 3.2): **COUNTRY – PROCESS**

### 3.7.16. Country of Disassembly: AI (425)

The Application Identifier (425) indicates that the GS1 Application Identifier data field contains the ISO country code of the country of disassembly of the trade item.

The ISO country code field contains the three-digit country code of the numerical international standard ISO 3166 that is the country of disassembly.

**Note:** It is the responsibility of the party doing the disassembly of the trade item to allocate the correct country code.

Figure 3.7.16 - 1

Format of the Element String	
Application Identifier	ISO Country Code
4 2 5	N <sub>1</sub> N <sub>2</sub> N <sub>3</sub>

The data transmitted from the bar code reader means that the ISO country code denoting the country of disassembly of the respective trade item has been captured.

When indicating this Element String in the human readable section of a bar code label, the following Data Title should be used (see also Section 3.2): **COUNTRY – DISASSEMBLY**

### 3.7.17. Country Covering Full Process Chain: AI (426)

The Application Identifier (426) indicates that the GS1 Application Identifier data field contains the ISO country code of the country where all the processing of the trade item took place.

The ISO country code field contains the three-digit country code of the numerical international standard ISO 3166 that is the country of full processing.

**Note:** If this AI is used, the full processing of a trade item must have taken place in a single country. This is particularly important in certain applications (e.g., covering a livestock animal's birth, fattening, and slaughter) where processing could take place in different countries. In situations like this, AI (426) may not be used. It is the responsibility of the supplier to allocate the correct country code.

Figure 3.7.17 - 1

Format of the Element String
------------------------------

Application Identifier	ISO Country Code
4 2 6	N <sub>1</sub> N <sub>2</sub> N <sub>3</sub>

The data transmitted from the bar code reader means that the ISO country code denoting the country of full processing of the trade item has been captured.

When indicating this Element String in the human readable section of a bar code label, the following Data Title should be used (see also Section 3.2): **COUNTRY – FULL PROCESS**

### 3.8. GS1 Application Identifiers starting with digit 7

#### 3.8.1. Seventy Series AIs - Cautionary Note

Application Identifiers issued in the 70 series are assigned when an Application Identifier request meets all the normal criteria except one of the following:

- The application is not multi-sectoral.
- The application is restricted to a country or a region (e.g., is not global).

##### 3.8.1.1. Stock Number (NSN): AI (7001)

The Application Identifier (7001) indicates that the GS1 Application Identifier data field contains a NATO stock number.

The NATO stock number is the number allocated to any item of supply in the NATO Alliance. It is the responsibility of the country that manufactures or controls the design of the item to allocate the number.

**Note:** This Element String is only for use within the context of the supply within the NATO Alliance. Use of it is subject to the rules and regulations of the Allied Committee 135 (AC/135), the NATO Group of National Directors on Codification.

Figure 3.8.1.1 - 1

	Format of the Element String		
Application Identifier	NATO Supply Classification	Assigning Country	Sequential Number
	→	→	→
7001	N <sub>1</sub> N <sub>2</sub> N <sub>3</sub> N <sub>4</sub>	N <sub>5</sub> N <sub>6</sub>	N <sub>7</sub> N <sub>8</sub> N <sub>9</sub> N <sub>10</sub> N <sub>11</sub> N <sub>12</sub> N <sub>13</sub>

The data transmitted from the bar code reader means that the Element String denoting a NATO stock number has been captured. As it is an attribute of a trade item, the NATO stock number should not be processed on its own, but together with the Global Trade Item Number (GTIN) of the trade item to which it relates.

When indicating this Element String in the human readable section of a bar code label, the following Data Title should be used (see also Section 3.2): **NSN**

### 3.8.1.2. UN/ECE Meat Carcasses and Cuts Classification: AI (7002)

The Application Identifier (7002) indicates that the GS1 Application Identifier data field contains a UN/ECE meat carcasses and cuts classification code.

The UN/ECE meat carcasses and cuts code is an attribute of a Global Trade Item Number (GTIN) that denotes the trade description of the product. It is an alphanumeric, variable length code up to 30 characters.


 **Note:** This Element String is only for use within the context of UN/ECE standards for the quality of meat carcasses and cuts (bovine, porcine, ovine, and caprine).

Figure 3.8.1.2 - 1

Format of the Element String	
Application Identifier	UN/ECE Product Classification
7 0 0 2	X <sub>1</sub> ————— variable length —————> X <sub>30</sub>

The data transmitted from the bar code reader means that the Element String denoting a UN/ECE meat carcasses and cuts code has been captured. As it is an attribute of a trade item, the UN/ECE meat carcasses and cuts code should not be processed on its own, but together with the Global Trade Item Number (GTIN) of the trade item to which it relates.

When indicating this Element String in the human readable section of a bar code label, the following Data Title should be used (see also Section 3.2): **MEAT CUT**

### 3.8.1.3. Expiration Date and Time: AI (7003)

Figure 3.8.1.3 - 1

Format of the Data Element					
Application Identifier	Expiration Date and Time				
	YY	MM	DD	HH	MM
7003	N <sub>1</sub> N <sub>2</sub>	N <sub>3</sub> N <sub>4</sub>	N <sub>5</sub> N <sub>6</sub>	N <sub>7</sub> N <sub>8</sub>	N <sub>9</sub> N <sub>10</sub>

The Application Identifier (7003) indicates that the data fields contain expiration date and time.

The manufacturer determines the expiration date and time, which is relevant only for short duration and for items that will not be sent on long distances and not outside of the time zone. A typical application of AI (7003) is in hospitals or public pharmacies for special, customised, products which may have a "life duration" shorter than one single day. The life duration varies according the pharmaceutical substances used in the treatment. The precise expiration date and time is defined at the end of the manufacturing process, and can be bar coded on the product label as an attribute to the item's GTIN. Where there is no business requirement to express the expiration date to the nearest hour (or less), AI (17) Expiration Date should be used.

**The structure is:**

- **Year:** the tens and units of the year (e.g., 2007 = 07), which is mandatory
- **Month:** the number of the month (e.g., January = 01), which is mandatory

- **Day:** the number of the day of the relevant month (e.g., second day = 02), which is mandatory.
- **Hour:** the number of the hour based on local 24-hour time (e.g., 2 p.m. = 14), which is mandatory
- **Minutes:** the number of the minutes based on local time (e.g., 15 minutes. = 15); if it is not necessary to specify the minutes, the field must be filled with two zeros. Time will then be interpreted as ending on the hour (e.g., 14:00 = expiry time at 14:00)

The data transmitted from the bar code reader means that the Element String denoting expiration date and time has been captured. As it is an attribute of a trade item, the expiration date and time should not be processed on its own, but together with the Global Trade Item Number (GTIN) of the trade item to which it relates.

When indicating this Element String in the human readable section of a bar code label, the following Data Title should be used (see also Section 3.2): **EXPIRY TIME**

- ✔ **Note:** This Element String can only specify dates in the range from 49 years in the past to 50 years in the future. Determination of the correct century is explained in Section 7.13.

#### 3.8.1.4. Approval Number of Processor with Three-Digit ISO Country Code: AI (703s)

The Application Identifier (703s) indicates that the GS1 Application Identifier data fields contain the ISO country code and approval number of the processor of a trade item. As many processors may be involved, each with an individual approval number, the fourth digit of the AI (s in the Figure below) indicates the sequence of the processors. For a typical meat supply chain, the following sequence would be used:

- 7030: slaughterhouse
- 7031: first deboning/cutting hall
- 7032 to 7039: second through ninth processing location (cutting hall)

The ISO country code contains the three-digit country number of the numerical international standard ISO 3166 that relates to the following approval number of processor.

The approval number of processor is an attribute to a Global Trade Item Number (GTIN). It designates the approval number of the company who did the processing.

- ✔ **Note:** The approval number is usually assigned by a national or pluri-national authority to processors in the food supply chain. These authorities may use the Global Location Number (GLN) (see Section 2.4) for this purpose. The approval number (or GLN) remains with the item regardless of whether or not it changes ownership or function.

Figure 3.8.1.4 - 1

Format of the Element String		
Application Identifier	ISO Country Code	Approval Number of Processor
7 0 3 s	N <sub>1</sub> N <sub>2</sub> N <sub>3</sub>	X <sub>4</sub> ——— variable length ———> X <sub>30</sub>

The data transmitted from the bar code reader means that the Element String for ISO country code and approval number of processor has been captured. As it is an attribute of a trade item, the ISO

country code and approval number of processor should not be processed on their own, but together with the Global Trade Item Number (GTIN) of the trade item to which they relate.

When indicating this Element String in the human readable section of a bar code label, the following Data Title should be used (see also Section 3.2): **PROCESSOR # s**

### 3.9. GS1 Application Identifiers starting with digit 8

#### 3.9.1. Roll Products - Width, Length, Core Diameter, Direction, Splices: AI (8001)

The Application Identifier (8001) indicates that the GS1 Application Identifier data fields contain the variable attributes of a roll product. Depending on the method of production, some roll products cannot be numbered according to standard criteria that have been determined in advance. They are, therefore, classified as variable items. For those products where the standard trade measures are not sufficient, the following guidelines should be used.

The identification of a roll product consists of the Global Trade Item Number (GTIN) and the variable attributes. The basic product (e.g., a certain type of paper) is included as data in the GTIN-14 ID Number (see Section 2.1.6), and the variables contain information about the special features of the particular item that has been produced.

The variable values of a roll product, N1 to N14, consist of the following data:

- N1 to N4: slit width in millimetres (width of the roll)
- N5 to N9: actual length in metres
- N10 to N12: internal core diameter in millimetres
- N13: winding direction (face out 0, face in 1, undefined 9)
- N14: number of splices (0 to 8 = actual number, 9 = number unknown)

Figure 3.9.1 - 1

Format of the Element String	
Application Identifier	Variable Values of a Roll Product
8 0 0 1	N <sub>1</sub> N <sub>2</sub> N <sub>3</sub> N <sub>4</sub>   N <sub>5</sub> N <sub>6</sub> N <sub>7</sub> N <sub>8</sub> N <sub>9</sub>   N <sub>10</sub> N <sub>11</sub> N <sub>12</sub>   N <sub>13</sub>   N <sub>14</sub>

The data transmitted from the bar code reader means that the variable attributes of the identification of a roll product trade item have been captured. The variable attributes may be processed together with the simultaneously required GTIN of that trade item (see Section 3.3.3).

When indicating this Element String in the human readable section of a bar code label, the following Data Title should be used (see also Section 3.2): **DIMENSIONS**

#### 3.9.2. Cellular Mobile Telephone Identifier: AI (8002)

The Application Identifier (8002) indicates that the GS1 Application Identifier data field contains the serial number of a cellular mobile telephone.

The Serial Number field is alphanumeric and may contain all characters contained in Figure 7.12 - 1. A national or pluri-national authority usually assigns the number. It uniquely identifies each mobile telephone within a given authority for special control purposes. It is not considered as an attribute of the identification of the telephone as a trade item.

Figure 3.9.2 - 1

Format of the Element String	
Application Identifier	Serial Number
8 0 0 2	X <sub>1</sub> ————— variable —————> X <sub>20</sub>

The data transmitted from the bar code reader means that the Element String denoting an electronic serial identifier of a cellular mobile telephone has been captured. The electronic serial identifier may be processed according to the particular application requirements.

When indicating this Element String in the human readable section of a bar code label, the following Data Title should be used (see also Section 3.2): **CMT NO.**

### 3.9.3. Global Returnable Asset Identifier (GRAI): AI (8003)

The Application Identifier (8003) indicates that the GS1 Application Identifier data field contains the GRAI (Global Returnable Asset Identifier). The GRAI is used to identify returnable assets.

The GS1 Company Prefix is the one allocated to the owner of the asset (see Section 1.5). It makes the number unique worldwide. The zero in the leftmost position is added to generate 14 digits in the asset identification number field.

The Asset Type is a number assigned by the owner of the asset to uniquely identify each type of asset.

The Check Digit is explained in Section 7.10. Its verification, which must be carried out in the application software, ensures that the number is correctly composed.

The optional serial number is assigned by the owner of the asset. It identifies an individual asset within a given Asset Type. The field is alphanumeric and may contain all characters contained in Figure 7.12 - 1.

Figure 3.9.3 - 1

Format of the Element String				
Application Identifier	Global Returnable Asset Identifier (GRAI)			
	GS1 Company Prefix —————>	Asset Type ←————	Check Digit	Serial Number (Optional)
8 0 0 3	0 N <sub>1</sub> N <sub>2</sub> N <sub>3</sub> N <sub>4</sub> N <sub>5</sub> N <sub>6</sub> N <sub>7</sub> N <sub>8</sub> N <sub>9</sub> N <sub>10</sub> N <sub>11</sub> N <sub>12</sub>		N <sub>13</sub>	X <sub>1</sub> variable X <sub>16</sub>

The data transmitted from the bar code reader means that the GRAI has been captured. It may be processed according to the particular application requirements.

When indicating this Element String in the human readable section of a bar code label, the following Data Title should be used (see also Section 3.2): **GRAI**

### 3.9.4. Global Individual Asset Identifier (GIAI): AI (8004)

The Application Identifier (8004) indicates that the GS1 Application Identifier data field contains a GIAI (Global Individual Asset Identifier). This Element String may be used for the unique identification of individual assets to provide a means to store relevant data.

**Note:** This Element String must never be used to identify the entity as a trade item or logistic unit. If an asset is transferred between parties, the GIAI cannot be used for ordering the asset. However, asset identification may be exchanged between parties for the purpose of traceability

The GIAI uses the GS1 Company Prefix of the company assigning the Individual Asset Reference. The structure and numbering of the Individual Asset Reference is determined by the holder of the GS1 Company Prefix. It may contain all characters contained in Figure 7.12 - 1.

Figure 3.9.4 – 1

Format of the Element String	
Application Identifier	Global Individual Asset Identifier (GIAI)
	<div style="display: flex; justify-content: space-between; align-items: center;"> <div style="text-align: center;"> <p>GS1 Company Prefix</p> <p>→</p> </div> <div style="text-align: center;"> <p>Individual Asset Reference</p> <p>→</p> </div> </div>
8 0 0 4	$N_1 \dots N_i$ $X_{i+1} \dots$ variable length $X_j (j \leq 30)$

The data transmitted from the bar code reader means that the Element String of a GIAI has been captured. It may be processed according to the particular application requirements.

When indicating this Element String in the human readable section of a bar code label, the following Data Title should be used (see also Section 3.2): **GIAI**

### 3.9.5. Price per Unit of Measure: AI (8005)

The Application Identifier (8005) indicates that the GS1 Application Identifier data field contains a price per unit of measure. This Element String is used to indicate the price per unit of measure of price marked goods on a Variable Measure Trade Item to discriminate price variants of the same item. It is considered as an attribute of the respective trade item and not as part of its identification.

Content and structure of the Price Per Unit of Measure field are left to the discretion of the trading partners.

Figure 3.9.5 – 1

Format of the Element String	
Application Identifier	Price Per Unit of Measure
8 0 0 5	$N_1 N_2 N_3 N_4 N_5 N_6$

The data transmitted from the bar code reader means that the Element String denoting the price per unit of measure has been captured. This Element String must always be decoded and processed together with the Global Trade Item Number (GTIN) from the same item.

When indicating this Element String in the human readable section of a bar code label, the following Data Title should be used (see also Section 3.2): **PRICE PER UNIT**

### 3.9.6. Identification of the Components of a Trade Item: AI (8006)

The Application Identifier (8006) indicates that the GS1 Application Identifier data fields contain the identification of the trade item and the enumeration of its components.

The GTIN is the item number under which the whole item is traded. For the structures of the GTIN, see Section 4.

The relative number field shows the consecutive number of a particular component within the assembly. A component of a given trade item must always be identical for the respective trade item.

The Total Number of Components in the Assembly field shows the total number of components of the trade item.

**Figure 3.9.6 - 1**

Format of the Element String			
Application Identifier	Global Trade Item Number (GTIN)	Relative Number of the Component Within the Assembly	Total Number of Components in the Assembly
8 0 0 6	N <sub>1</sub> N <sub>2</sub> N <sub>3</sub> ..... N <sub>11</sub> N <sub>13</sub> N <sub>14</sub>	N <sub>15</sub> N <sub>16</sub>	N <sub>17</sub> N <sub>18</sub>

The data transmitted from the bar code reader means that the identification of a component of a trade item has been captured. Components may be processed according to the particular application requirements.

When indicating this Element String in the human readable section of a bar code label, the following Data Title should be used (see also Section 3.2): **GCTIN**

### 3.9.7. International Bank Account Number (IBAN): AI (8007)

The Application Identifier (8007) indicates that the GS1 Application Identifier data field contains the international bank account identifier.

The international bank account number (IBAN), AI (8007), defined as ISO 13616, indicates to which account the amount of the respective payment slip is to be transferred. The invoicing party determines the applicable bank account number. The data field is alphanumeric and may contain all characters contained in Figure 7.12 – 1.

**Figure 3.9.7 - 1**

Format of the Element String	
Application Identifier	International Bank Account Number
8 0 0 7	X <sub>1</sub> ——— variable ———→ X <sub>30</sub>

The data string transmitted by the bar code reader means that an IBAN has been captured. The IBAN must be processed together with the payment slip reference number, AI (8020), and the Global Location Number (GLN) of the invoicing party that is captured from the same payment slip.

When indicating this Element String in the human readable section of a bar code label, the following Data Title should be used (see also Section 3.2): **IBAN**

### 3.9.8. Date and Time of Production: AI (8008)

The Application Identifier (8008) indicates that the GS1 Application Identifier data fields contain a date and time of production (or assembly). The date and time of production is determined by the manufacturer. The date and time may refer to the trade item itself or to the items contained.

The structure is:

- Year: the tens and units of the year (e.g., 2000 = 00), which is mandatory
- Month: the number of the month (e.g., January = 01), which is mandatory
- Day: the number of the day of the relevant month (e.g., second day = 02), which is mandatory
- Hour: the number of the hour based on local time (e.g., 2 p.m. = 14), which is mandatory
- Minutes: may be dropped if not required
- Seconds: may be dropped if not required

**Note:** This Element String can only specify dates ranging from 49 years in the past to 50 years in the future. Determination of the correct century is explained in Section 7.13.

**Figure 3.9.8 - 1**

Format of the Data Element						
Application Identifier	Date and Time of Production					
	YY	MM	DD	HH	MM	SS
8008	N <sub>1</sub> N <sub>2</sub>	N <sub>3</sub> N <sub>4</sub>	N <sub>5</sub> N <sub>6</sub>	N <sub>7</sub> N <sub>8</sub>	N <sub>9</sub> N <sub>10</sub>	N <sub>11</sub> N <sub>12</sub>

The data transmitted from the bar code reader means that the Element String denoting date and time of production has been captured. As it is an attribute of a trade item, the date and time of production should not be processed on its own, but together with the Global Trade Item Number (GTIN) of the trade item to which it relates.

When indicating this Element String in the human readable section of a bar code label, the following Data Title should be used (see also Section 3.2): **PROD TIME**

### 3.9.9. Global Service Relation Number (GSRN): AI (8018)

The Application Identifier (8018) indicates that the GS1 Application Identifier data field contains a GSRN (Global Service Relation Number). The GSRN is used to identify the recipient of services in the context of a service relationship. This Element String provides a means for the service provider to store data relevant to services provided to the recipient.

The GS1 Company Prefix is the one allocated to the service provider (see Section 1.5). It makes the number unique worldwide.

The Service Reference is assigned by the service provider. The structure and content of the Service Reference is at the discretion of the particular service provider.

The Check Digit is explained in Section 7.10. Its verification, which must be carried out in the application software, ensures that the number is correctly composed.

**Figure 3.9.9 - 1**

Format of the Element String		
Application Identifier	Global Service Relation Number (GSRN)	
	GS1 Company Prefix —————→	←————— Service Reference
8 0 1 8	N <sub>1</sub> N <sub>2</sub> N <sub>3</sub> N <sub>4</sub> N <sub>5</sub> N <sub>6</sub> N <sub>7</sub> N <sub>8</sub> N <sub>9</sub> N <sub>10</sub> N <sub>11</sub> N <sub>12</sub> N <sub>13</sub> N <sub>14</sub> N <sub>15</sub> N <sub>16</sub> N <sub>17</sub>	N <sub>18</sub> Check Digit

The data transmitted from the bar code reader means that the Element String for a GSRN has been captured. It may be processed according to the particular application requirements.

When indicating this Element String in the human readable section of a bar code label, the following Data Title should be used (see also Section 3.2): **GSRN**

### 3.9.10. Payment Slip Reference Number: AI (8020)

The Application Identifier (8020) indicates that the GS1 Application Identifier data field contains a payment slip reference number.

The payment slip reference number, assigned by the invoicing party, identifies a payment slip within a given Global Location Number (GLN) of an invoicing party. Together with the GLN of the invoicing party, the payment slip reference number uniquely identifies a payment slip. The data field is alphanumeric and may contain all characters contained in Figure 7.12 - 1.

Figure 3.9.10 - 1

Format of the Element String	
Application Identifier	Payment Slip Reference Number
8 0 2 0	X <sub>1</sub> ——— variable ———> X <sub>25</sub>

The data string transmitted from the bar code reader means that a payment slip reference number has been captured. It must be processed together with the GLN of the invoicing party that is captured from the same payment slip.

When indicating this Element String in the human readable section of a bar code label, the following Data Title should be used (see also Section 3.2): **REF NO.**

### 3.9.11. GS1-128 Coupon Extended Bar Code: AIs (8100 - 8102)

The Application Identifiers (8100) to (8102) indicate that the GS1 Application Identifier data fields contain data supplementary to a GS1 US coupon identification.

The filler digit 0 is used in AI (8102) to generate an even number of digits in the Element String.

The U.P.C. Prefix is the digit that is preceded by a zero and followed by a Company Number to form the U.P.C. Company Prefix. The Offer Code is assigned by the issuer and identifies a particular promotion.

The expiration date indicates the end of the redemption period of the coupon.

Figure 3.9.11 - 1

Formats of the Element Strings				
Application Identifier	Filler Digit	U.P.C. Prefix	Offer Code	Expiration Date (Month + Year)
8 1 0 0		N <sub>1</sub>	N <sub>2</sub> N <sub>3</sub> N <sub>4</sub> N <sub>5</sub> N <sub>6</sub>	
8 1 0 1		N <sub>1</sub>	N <sub>2</sub> N <sub>3</sub> N <sub>4</sub> N <sub>5</sub> N <sub>6</sub>	N <sub>7</sub> N <sub>8</sub> N <sub>9</sub> N <sub>10</sub>
8 1 0 2	0	N <sub>2</sub>		

The data string transmitted from the bar code reader means that a GS1-128 Coupon Extended Bar Code has been captured.

### 3.9.12. Coupon Code Identification for Use in North America (AI 8110)

The coupon bar code is constructed by starting with a coupon Application Identifier of 8110, followed by the required and optional data elements, until all desired data is encoded (or the limit of 30 digits is reached).

Figure 3.9.12 - 1

Format of the Element String	
Application Identifier	Formatted according to rules of GS1 Canada or GS1 US
8 1 1 0	X <sub>1</sub> ——— variable ———> X <sub>30</sub>

The data string transmitted from the bar code reader means that a Coupon Code for Use in North America has been captured.

## 3.10. GS1 Application Identifiers starting with digit 9

### 3.10.1. Information Mutually Agreed Between Trading Partners (Including FACT Data Identifiers): AI (90)


The Application Identifier (90) indicates that the GS1 Application Identifier data field contains any information mutually agreed between trading partners.

The data field shows the information agreed between the two trading partners. The field is alphanumeric and may contain all characters contained in Figure 7.12 – 1. It may also be used to incorporate data preceded by FACT Data Identifiers.


Figure 3.10.1 - 1

Format of the Element String	
Application Identifier	Data Field
9 0	X <sub>1</sub> ——— variable length ———> X <sub>30</sub>

The data transmitted from the bar code reader means that the Element String AI (90) has been captured. As the data field may contain any information, processing is subject to prior agreement between trading partners.

 **Warning:** The bar code symbol carrying this Element String should be removed from any item that leaves the jurisdiction of the trading partners.

When indicating this Element String in the human readable section of a bar code label, the following Data Title should be used (see also Section 3.2): **INTERNAL**

 **Note:** The actual data title may be specified by the issuer of the data.

### 3.10.2. Company Internal Information: AIs (91 - 99)


The Application Identifier (A1 A2) assigned to company internal information is AI (91 to 99).

The GS1 Application Identifier data field may contain any company internal information. The field is alphanumeric and may show all characters contained in Figure 7.12 - 1.


Figure 3.10.2 - 1

Format of the Element String	
Application Identifier	Data Field
A <sub>1</sub> A <sub>2</sub>	X <sub>1</sub> ————— variable length —————> X <sub>30</sub>

The data transmitted from the bar code reader means that the Element String containing company internal information has been captured. Processing is to be organised by the using company.

 **Warning:** This Element String should be removed from any item that leaves the jurisdiction of the company.

When indicating this Element String in the human readable section of a bar code label, the following Data Title should be used (see also Section 3.2): **INTERNAL**

 **Note:** The actual data may be specified by the issuer of the data.

## 3.11. Compatibility of EPCglobal Tag Data Standard and GS1 General Specifications

The GS1 Application Identifiers, defined in this section of the GS1 General Specifications, may be used in GS1 endorsed GS1 Bar Codes in line with the Application Standards outlined in Section 2. GS1 Application Identifiers may also be used in GS1 endorsed RFID tags as defined in the latest version of the EPC Tag Data Standards that can be found on:

<http://www.epcglobalinc.org/standards/tds/>



## Section 4. Application Rules

- Introduction
- Rules for Keys
- GTIN Rules
- SSCC Rules
- Allocating GS1 System Asset Identifiers
- GLN Rules
- GSRN Rules
- GDTI Rules
- Data Relationships

Whilst every effort has been made to ensure that the guidelines to use the GS1 standards contained in the document are correct, GS1 and any other party involved in the creation of the document HEREBY STATE that the document is provided without warranty, either expressed or implied, of accuracy or fitness for purpose, AND HEREBY DISCLAIM any liability, direct or indirect, for damages or loss relating to the use of the document. The document may be modified, subject to developments in technology, changes to the standards, or new legal requirements.

Several products and company names mentioned herein may be trademarks and/or registered trademarks of their respective companies.

## 4.1. Introduction

The main purpose of Automatic Data Capture (ADC) is to replace manual entry of visually captured information. This implies that an ADC message has to provide all information required for a transaction without human intervention. GS1 System data may be used, for example, to record entities in computer files, to sort goods on conveyor belts, to check completeness of a consignment, to verify dates, and to record physical stock taking.

Element Strings may be applied directly on physical goods or printed in catalogues or documents. The scanning source and the type of transaction determine the required information in a given business application. Since all ADC data is being used in Electronic Data Processing (EDP) applications, strict validation of data to be processed is an absolute prerequisite.

For correct processing of scanned data, certain business applications may require the association of Element Strings representing a particular combination of identification data. The GS1 System enables users to achieve the needed level of data accuracy through the use of adequate Element Strings.

The logical set up of the data standard of the GS1 System enables system users to validate scanned data messages (see Section 7, AIDC Validation Rules).

Validation is affected on two levels. The first is validation of the data for conformity with system rules (e.g., to provide a message that contains all information to be processed logically without human intervention). The second level is validation of the data for conformity with the requirements of a particular business application.

Sections [4.9.1](#) and [4.9.2](#) show the rules for the first verification level (e.g., validate data to conform with the system logic). Section [4.9.1](#) defines the pairs of Element Strings that cannot appear on the same physical entity. Section [4.9.2](#) defines the Element Strings that mandate the appearance of another Element String on the same physical entity. All other combinations of Element Strings are possible at the first level of verification, although they may not make sense at the second, the application level.

## 4.2. Rules for Keys

The tables in the sub-section below refer to a sequential rule number for the keys rule and are linked to the appropriate wording. The columns are used, where appropriate, to indicate which rules apply to an industry. Section 2 will point to this table for directions on which rules to apply to an application.

### 4.2.1. GTIN Rules

Rules	Section / Link	GTIN Rule #
<a href="#">Allocation General Rule</a>	<a href="#">4.3.1.1</a>	1
<a href="#">Allocation and Responsibility for Branded Items</a>	<a href="#">4.3.1.2.1</a>	2
<a href="#">Allocation and Responsibility Exceptions and Non-Branded Items</a>	<a href="#">4.3.1.2.2</a>	3
<a href="#">Management of Uniqueness</a>	<a href="#">4.3.1.3.1</a>	4
<a href="#">Pre-Defined Characteristics</a>	<a href="#">4.3.1.3.2</a>	5
<a href="#">Pre-Priced Merchandise</a>	<a href="#">4.3.1.3.3</a>	6
<a href="#">Promotional Variants</a>	<a href="#">4.3.1.3.4</a>	7
<a href="#">Trade Item Changes</a>	<a href="#">4.3.1.3.5</a>	8
<a href="#">Variants for Groupings</a>	<a href="#">4.3.1.3.6</a>	9

Rules	Section / Link	GTIN Rule #
<a href="#">Lead Time in Re-Using a GTIN</a>	<a href="#">4.3.1.4</a>	10
<a href="#">Data Alignment</a>	<a href="#">4.3.1.5</a>	11
<a href="#">GTIN Allocation Rules</a>	<a href="http://www.gs1.org/gtinrules">www.gs1.org/gtinrules</a>	12

#### 4.2.2. SSCC Rules

Rules	Section	SSCC Rule #
<a href="#">Allocating Serial Shipping Container Codes</a>	<a href="#">4.4.1</a>	1

#### 4.2.3. Assets Rules

Rules	Section	Asset Rule #
<a href="#">GS1 System Asset Identifiers</a>	<a href="#">4.5.1.1</a>	1
<a href="#">Uniqueness of Asset Identifiers</a>	<a href="#">4.5.1.2</a>	2
<a href="#">Best Practice</a>	<a href="#">4.5.1.3</a>	3
<a href="#">Change of Asset Ownership</a>	<a href="#">4.5.2</a>	4
<a href="#">Allocating Global Returnable Asset Identifiers (GRAIs): AI (8003)</a>	<a href="#">4.5.1.4</a>	5
<a href="#">Serial Number (Optional)</a>	<a href="#">4.5.1.6</a>	6
<a href="#">Allocating Global Individual Asset Identifiers (GIAs): AI (8004)</a>	<a href="#">4.5.1.7</a>	7

#### 4.2.4. GLN Rules

Rules	Section/Link	GLN Rule #
<a href="#">General Rule</a>	<a href="#">4.6.1.1</a>	1
<a href="#">Company Liquidation, Acquisition, and Mergers: Change of Ownership</a>	<a href="#">4.6.1.2</a>	2
<a href="#">Relocations</a>	<a href="#">4.6.1.3</a>	3
<a href="#">Physical Location, Ownership Remain Unchanged; Associated Data for a Particular GLN Change</a>	<a href="#">4.6.1.4</a>	4
<a href="#">GLN Allocation Rules</a>	<a href="http://www.gs1.org/glnrules">www.gs1.org/glnrules</a>	5

## 4.3. GTIN Rules

### 4.3.1. Allocating the Numbers

#### 4.3.1.1. Allocation General Rule

A Global Trade Item Number (GTIN) is used to identify any item (trade item or service) upon which there is a need to retrieve pre-defined information and that may be priced or ordered or invoiced at any point in any supply chain. A separate, unique GTIN is required whenever any of the pre-defined characteristics of an item are different in any way that is relevant to the trading process. As a guiding principle, if the customer is expected to distinguish a new trade item from an old trade item and purchase accordingly, a new GTIN should be assigned to the new trade item. This will ensure the product package and shelf edge label declarations should appear the same to the consumer. However, any law or regulation that contradicts these rules shall supersede these rules.

Specific rules that apply to prevalent industry practices have been endorsed by the Global Commerce Initiative Board, for the Fast Moving Consumer Goods (FMCG) industry. These rules covering many common business cases can be found at [www.gs1.org/gtinrules](http://www.gs1.org/gtinrules). While all GS1 standards are voluntary, the rules are intended to drive normative practice within the FMCG sector.

Specific rules that apply to packaging and raw material trade items supplied to manufacturing companies can be found at <http://www.gs1.org/gtinrules/index.php/tid=29>.

#### 4.3.1.2. Responsibility

##### 4.3.1.2.1. Allocation and Responsibility for Branded Items

The brand owner, the organisation that owns the specifications of the trade item regardless of where and by whom it is manufactured, is normally responsible for the allocation of the Global Trade Item Number (GTIN). On joining a GS1 Member Organisation, the brand owner receives a GS1 Company Prefix, which is for the sole use of the company to which it is assigned. The GS1 Company Prefix may not be sold, leased, or given, in whole or in part, for use by any other company.

The brand owner is the organisation that owns the trade item specifications and may be:

- The manufacturer or supplier: The company that manufactures the trade item or has it manufactured, in any country, and sells it under its own brand name
- The importer or wholesaler: The importer or wholesaler that has the trade item manufactured, in any country and sells it under its own brand name or the importer or wholesaler that changes the trade item (for example by modifying the packaging of the trade item)
- The retailer: The retailer that has the trade item manufactured, in any country, and sells it under its own brand

##### 4.3.1.2.2. Allocation and Responsibility Exceptions and Non-Branded Items

There are some exceptions to the rules regarding responsibility described in

- Non-Branded Items: Items without a brand name and generic items (not private labels) are still assigned Global Trade Item Numbers (GTIN) by their manufacturer. As different manufacturers and/or suppliers may supply items that appear identical to the buyer (this could be a consumer as well as a retailer or manufacturer), it is possible that items that are apparently the same have different GTINs. Companies that trade in these items need to organise their computer applications (e.g., replenishment programs) to cope with this eventuality. Examples of items that sometimes have no brand are apples, plasterboard,

candles, and drinking glasses. Examples for trade items that sometimes have no brand and are not intended for retail include salt, fragrances, and food cans.

- **Customer Specific Items:** If a trade item is made specifically for one trade customer (buyer) and is orderable only by this customer, then the buyer assigns the GTIN. In this case the GTIN should be formed from the customer's GS1 Company Prefix (see Section 1.5). If the supplier (seller) sells a trade item to more than one buyer or intends to sell to more than one buyer, then the seller assigns the GTIN.
- **Other Exceptions:** If the brand owner does not assign a GTIN, the importer or another intermediary can assign an item a temporary GTIN. This would imply that the importer takes on the role of the brand owner and could, for example, register the product in a data catalogue. This temporary GTIN may be used until a GTIN is assigned in the normal way. Alternatively, a retail organisation can assign an internal number to an item that does not yet have a GTIN assigned to it only if the item is used within its own stores.

### 4.3.1.3. Guidelines for Allocating the Global Trade Item Number (GTIN)

#### 4.3.1.3.1. Management of Uniqueness

Global Trade Item Numbers (GTIN) must be allocated uniquely. GTINs should not contain any intelligence or parsable strings. The embedding of internal codes is discouraged because it is often found that the rules for changing them differ from the rules for changing a GTIN.

For some product types (e.g., Healthcare items) it is common for national regulators to require the submission of a product filing from a legal entity based within the jurisdiction of the regulator. Such arrangements have no direct impact on GTIN Allocation but need to be covered by the normal contractual arrangements (e.g., licensed distributor, subsidiary, reseller).

#### 4.3.1.3.2. Pre-Defined Characteristics

Although this list is not exhaustive, the basic pre-defined characteristics of a trade item are:

- The product name, product brand, and product description
- The trade item type and variety
- The net quantity of trade item (weight, volume, or other dimension impacting trade)
- If the trade item is a grouping, the number of elementary items contained, and their subdivision in sub-packaging units, the nature of the grouping (e.g., carton, pallet, box-pallet, flat-pallet)

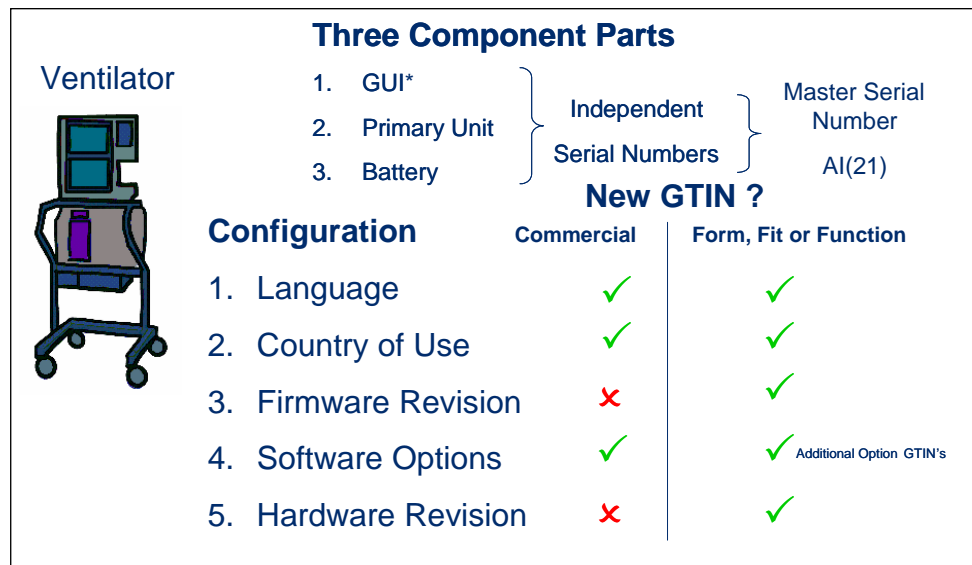
A modification to any of the basic elements that characterise a trade item will usually lead to a change in the Global Trade Item Number (GTIN).

- ✓ **Note:** Price is not a relevant criterion for changing a GTIN except when the price is printed directly on the trade item.
- ✓ **Note:** National, federal, or local regulations may take precedence over this rule. For example, in some industries, such as healthcare, regulations or other requirements may dictate that any trade item changes require a new GTIN.
- ✓ **Note:** For complex products, such as some Medical Devices, key consideration for GTIN Allocation is the commercialisation of the product (e.g., different for pricing or ordering or invoicing). If the product is 'different' a 'different GTIN' is required. The figure below is a scenario to represent the difficulties in determining when a GTIN change is necessary for

complex medical devices, depending upon how the device is viewed (i.e., from a commercial and/or Form, Fit, Function perspective). Nominally the commercial aspects of an item determine a GTIN change, the objective is to recognise that other important factors reside which may not necessarily signify a commercialization shift, but would impact the GTIN assignment – particularly in the Healthcare industry. It is the brand owner's responsibility to manage appropriately the configuration of any complex device and its appropriate GTIN(s) assignment. The example shows major hardware components managed by GTIN and Serial Number combinations, recognising that within this complex medical device there are other potential parameters where configuration change must be managed; GTIN change may be dictated based on the manufacturers change management process.

It is the Brand Owner that decides upon the identification requirement.

**Figure 4.3.1.3.2 -1 - Example of the complexity of a Medical Device product with regard to GTIN Allocation**



\* GUI: Graphical User Interface

Typically the gross dimensions of a trade item communicated via the item file that do not affect net trade item quantity or measure do not impact the GTIN assignment. However, as a general rule if any gross dimension (e.g., length, depth, weight) changes by more than 20 percent, a new GTIN is required. Changes below 20 percent may require a new GTIN at the discretion of the brand owner.

In all cases, a change to a GTIN for the trade item at a lower level of packaging will always lead to a change of any GTIN used for associated packaging at higher grouping levels.

#### 4.3.1.3.3. Pre-Priced Merchandise

Pre-pricing is discouraged as a trade practice as it introduces complexity for trade item file maintenance throughout the supply chain. If, however, the price that the consumer will pay is marked on the item, the Global Trade Item Number (GTIN) should be changed when the priced marked on the item changes.

**Note:** National, federal, or local regulations may take precedence over this guideline.

#### 4.3.1.3.4. Promotional Variants

A promotion is a temporary change to a trade item, which modifies the presentation of the trade item. It usually coexists with the standard trade item.

- Promotional variants of trade items that affect the net weight or volume of the trade item must be allocated a separate, unique Global Trade Item Number (GTIN). Examples include an attached free additional item or 10 percent extra free.
- Promotional variants of trade items may impact the logistic weight or dimension of the trade item by more than 20 percent. In this case, the promotional variants must be allocated a separate, unique GTIN.
- Promotional variants of trade items where a price reduction is explicitly specified on the pack (flash packs) must be allocated a separate, unique GTIN unless local trade practices or price marking legislation dictate otherwise. An example would be a 10 cents off offer.
- Each seasonal promotion of a trade item should be allocated a separate, unique GTIN. An example would be chocolate that is over-wrapped for Easter.
- Other promotional variants should not be allocated a separate, unique GTIN. Examples include money off coupon, free gift inside (unless this causes an increase in gross weight by more than 20 percent), "send for" offer, competition offer, or samples sent directly to consumer bypassing the retail Point-of-Sale.

#### 4.3.1.3.5. Trade Item Changes

Trade item changes are any change or improvement during the life of a trade item. The "new" trade item replaces the old one. Should the brand owner decide to create a variant (e.g., with different ingredients) in parallel with the standard trade item, then a separate, unique Global Trade Item Number (GTIN) has to be allocated.

- Minor trade item changes or improvements do not require the allocation of a different GTIN. Examples include label artwork redesign, minor trade item description changes that do not impact the supply chain, gross dimension change in any axis of less than 20 percent with content quantity or measure unchanged. This rule applies to retail consumer trade items (retail POS unit) and standard trade item groupings (orderable cases or pallets).

If a trade item's quantity or measure changes or if the consumer will be expected to distinguish between an old and new brand name or product description, then a new GTIN must be allocated.

#### 4.3.1.3.6. Variants for Groupings

- Trade items that are a standard and stable grouping of smaller units identified by a Global Trade Item Number (GTIN) must be allocated a separate GTIN whenever there is a change to the GTIN of any of the units contained.
- For trade items containing units that are themselves promotional variants or minor trade item variants of trade items whose GTINs remain unchanged, the rule is the following:
  - If the trade item has to be distinguished for effective ordering, handling, and tracking, a separate GTIN must be allocated to the trade item. Examples include promotions that are limited to certain geographical areas or date specific promotions.
  - If the identification of minor trade item variants is only relevant to the manufacturer, they should distinguish these variants by using the Element String product variant (AI 20). Examples include minor package design changes and side loading as opposed to top loading cases.

#### 4.3.1.4. Lead Time in Re-Using a GTIN

A GTIN allocated to a trade item that has become obsolete must not be re-used for another trade item until at least 48 months have elapsed after:

- the expiration date of the last original trade items produced with that number

-or-

- the last original trade items produced with that number have been supplied to the customer.

In the case of clothing the minimum retention period is reduced to 30 months.

Brand Owners should consider a longer period depending upon the type of goods and/or any regulatory framework. For example, steel beams may be stored for many years before entering the supply chain, and processes should be put in place to ensure that the GTIN is not reallocated for a significant period of time. Another example is found with very specific products within the healthcare sector, such as prescription drugs, implants, etc., where steps should be taken by the assigning company to ensure that the issued GTINs are not reallocated for a period well beyond the lifetime of the product or beyond the end of treatment.

In addition, when contemplating the re-use of a GTIN, consideration should be given to the use of data associated with the original GTIN by trading partners for statistical analysis or service records, which may continue long after the original trade item was last supplied.

If a GTIN has been assigned to an item, which was then never actually produced, the GTIN may be deleted from any catalogue immediately without first being marked as discontinued. In this exceptional case the GTIN may be re-used 12 months after deletion from the seller's catalogue.

#### 4.3.1.5. Data Alignment

When a new Global Trade Item Number (GTIN) is assigned to a trade item, it is essential that the brand owner provide the detailed information to trading partners about the item's characteristics. This information should be provided at as soon as possible before the trade item is actually traded.

Expediting GTIN information to buyers reduces order exception handling and reduces the lead-time in getting goods to the selling floor.

##### 4.3.1.5.1. Data Alignment Best Practice

A number of actions are vital to ensure that Global Trade Item Numbers (GTINs) are accurately communicated within the supply chain. These ensure that the data associated with any scanned bar code can be associated with accurate, up-to-date data. This is particularly essential for items scanned at the Point-of-Sale where the absence of accurate data may have legal implications.

The GTIN provides a supply chain solution for the identification of any item that is traded (priced, invoiced, or ordered). Overall supply chain costs are minimised by all partners in the supply chain adhering to identical allocation rules (see Section [4.3.1.6](#)).

The following best practices are proposed for all items. It has been developed by manufacturers, distributors, and retailers to help eliminate any confusion between product identification and product listing in the retailer's database in the supply chain.

1. GTIN allocation and the bar coding of the GTIN are technical processes with rules detailed in these *GS1 General Specifications*. Product listing is the act of adopting a new product in an assortment by a commercial organisation. Product listing is the result of commercial negotiations between purchaser and seller. For example, GTIN allocation should be independent from product listing.
2. For management reasons, or to ensure that correct information is communicated to the final consumer, changes to an item may require a new GTIN. A new GTIN does not automatically imply a new listing. For example, if a change requiring a new GTIN is made to a listed product, this should not automatically imply a new product listing is needed.

GTIN allocation and database listing are to be considered as two entirely autonomous decisions: GTIN allocation is not an object of negotiation.

The brand owner makes available to its client all information regarding the listed items, ideally with an EDI message or in an e-product catalogue, no later than at the time of item listing. In case of time limited promotions or a product evolution, this information will be communicated largely beforehand, thus allowing the retailer to validate this information and to circulate it internally.

#### 4.3.1.5.1.1. Primary Refrigeration State

It is recommended that GTIN allocation consider the primary refrigeration state of the product. When a product is regularly marketed in both chilled and frozen states, then two GTINs should be allocated for the product, one for each refrigeration state. However, if a product is only primarily marketed in one refrigeration state or the other, then only one GTIN for the product is necessary. For seasonal products which could be sold as chilled or frozen, such as spiral-cut hams and whole turkeys, the possibility of product being in delivered in either refrigeration state even though there is only one GTIN for the product needs to be noted when the retailer authorizes the product.

The key to efficient movement through the supply chain is good communications between retailer and packer. If packers only have frozen product available for a retailer that normally buys only chilled, the packer needs to communicate with the retailer to ensure that this is acceptable. This communication is critical in cases where over-production has required product with a "chilled" GTIN to be frozen before releasing it into the supply chain. To summarize:

1. Assign the GTIN based on the primary state in which the product is marketed (e.g., Chilled or Frozen).
2. If product is normally marketed in both a Chilled and Frozen state, assign two GTINs to the product, one for each state.
3. Suppliers should communicate carefully with retailers regarding the refrigeration state of seasonal or feature products than can be marketed in a Chilled, Tempered, or Frozen state.

#### 4.3.1.6. GTIN Allocation Definitions

The following terms may be useful when reviewing the GTIN Allocation Rules that are published on <http://www.gs1.org/gtinrules>:

- **Trade Item** – Any item (product or service) upon which there is a need to retrieve pre-defined information and that may be priced, ordered, or invoiced at any point in any supply chain.
- **Retail Consumer Trade Item** – The trade item intended to be sold to the end consumer at retail Point-of-Sale. They are identified with a unique GTIN-13, GTIN-12, or GTIN-8. (See the Section 2.).
- **Standard Trade Item Grouping** – A grouping of retail consumer trade items that is not intended for Point-of-Sale scanning. It is identified with a unique GTIN -14, GTIN -13, or GTIN -12.
- **Non-GTIN Pack** – A packaging level for trade items where there is no trading partner requirement for Global Trade Item Number (GTIN) identification. If a GTIN is required, then this item becomes a retail consumer trade item or standard trade item grouping.
- **Logistic Unit** – An item of any composition established for transport and/or storage that needs to be managed through the supply chain. It is identified with an SSCC (Serial Shipping Container Code).
- **Dynamic Assortment** – A standard trade item grouping that comprises a fixed count of a changing assortment of two or more different retail consumer trade items, each identified with a unique GTIN. All of the retail consumer trade items and their GTINs will have been communicated to the retailer before trading takes place. The retailer has accepted that the supplier may change the assortment without any prior notice. An example is a trade item grouping of ten toy cars that may contain any mix of possibly more than ten different toy cars that have been individually identified and notified to the retailer.

- **Pre-Defined Assortment** – A standard trade item grouping that comprises a fixed configuration of two or more different retail consumer items, each identified with a GTIN. Any change in the configuration of the assortment is considered a new trade item.

✔ **Note:** These rules are intended for global use. Exceptions may occur only when local regulatory or legal requirements mandate otherwise.

#### 4.3.1.7. GTIN Allocation Rules for Upstream Suppliers

Specific rules that apply to packaging and raw material trade items supplied to manufacturing companies can be found on <http://www.gs1.org/gtinrules/index.php/tid=29>.

Upstream suppliers are those companies that typically supply or manufacture trade items that are supplied to other companies for further processing. Examples of these trade items include raw ingredient and packaging materials.

A Global Trade Item Number (GTIN) must be assigned to each pre-defined trade item and any unit of measure used in the price, order, or invoice process.

✔ **Note:** These rules are intended for global use. Exceptions may occur only when local regulatory or legal requirements mandate otherwise.

#### 4.3.1.8. GTIN Allocation Considerations for Home Apparel and Home Fashion

The GSMP General Merchandise Work Team validated the existing Global Trade Item (GTIN) allocation rules and concluded that they are applicable to the apparel and home fashions product category. The content of this section extends the content in Section [4.3.1.8.1, Pre-pack/Multi-pack/Set-pack](#) to cover scenarios specific to apparel and home fashions and may be different in other sectors. This section is the result of the review of the Trade Item Identification and Communication Guidelines (VICS EDI) TIIC, May 2001, by the GSMP Work Team.

##### 4.3.1.8.1. Pre-pack/Multi-pack/Set-pack

For a pre-pack or standard assortment of trade items, each different item within the pre-pack will be assigned a GTIN maintaining the one-to-one relationship between trade item/colour ID/size ID and GTIN. Each GTIN must be marked so as to enable scanning at the Point-of-Sale. A separate, unique GTIN is assigned to each orderable pre-pack. This GTIN is not intended to be scanned at the retail Point-of-Sale. Different pre-packs of trade items are assigned different GTINs when either the component item or quantity contents of the pre-packs are different.

A multi-pack is a group of trade items (the same or different) that are intended to be sold as a single consumer unit at the Point-of-Sale (e.g., a three-pack of men's white T-shirts or a 12-piece set of glassware). A multi-pack is not intended to be broken apart and sold as individual trade items. A multi-pack is assigned a GTIN that is different from the GTIN that may be assigned to the individual trade items. Generally components of a multi-pack are not marked with individual GTINs. Each different multi-pack of the same trade items (e.g., three-pack socks versus six-pack socks) must have a different GTIN assigned. Each different multi-pack GTIN must also have its own trade item/colour ID/size ID.

For a set-pack, each different trade item within the set-pack will be assigned a GTIN, maintaining the one-to-one relationship between trade item/colour ID/size ID and the GTIN. The individual trade item GTIN must be marked to enable retail Point-of-Sale scanning and may or may not be orderable separately outside the set-pack(s). A separate, unique GTIN is assigned to each set-pack. Different set-packs are assigned different GTINs when either the trade item or quantity contents are different.

The figure below provides a summary of the requirements.

**Figure 4.3.1.8.1 – 1**

	PACK			INDIVIDUAL ITEMS OF THE PACK		
	Orderable	Sell to	GTIN by Retailer Marked Retailer Marked	Orderable	Sellable	GTIN by Consumer to Consumer
Pre-pack	Yes	No	Yes	Maybe	Yes	Yes
Multi-pack	Yes	Yes	Yes	No	No	No
Set-pack	Yes	Yes	Yes	Maybe	Yes	Yes

- Notes:**
- GTINs on individual trade items in a multi-pack are optional
  - GTINs in a set-pack are required because the individual pieces are available for sale to the consumer
  - Individual components of pre-packs and set-packs may be ordered separately based on individual partnership agreement

#### 4.3.1.8.2. Gift with Purchase/Purchase with Purchase/Collateral Item

A gift with purchase is a trade item given to a consumer as part of a promotional event, contingent on the consumer making a purchase of another item or items. A gift with purchase is considered inventory and has no retail value.

A purchase with purchase is a trade item sold to a consumer at a special price as part of a promotional event, contingent on the consumer purchasing another item or items. A purchase with purchase is considered inventory and has a retail value. When assigning and tracking Global Trade Item Numbers (GTINs) for gift with purchase and purchase with purchase trade items, GTINs should be assigned to all gift with purchase and purchase with purchase items and be marked with a GTIN to enable Point-of-Sale scanning.

A collateral item is a trade item delivered from a manufacturer to the retail selling floor that is not considered inventory and has no retail value (e.g., a display case that needs to be identified but has no retail value). GTINs should be assigned to all collateral items.

## 4.4. SSCC Rules

### 4.4.1. Allocating Serial Shipping Container Codes

#### 4.4.1.1. General Rule

An individual Serial Shipping Container Code (SSCC) is a unique number, which remains the same for the life of the logistic unit to which it is assigned. When assigning an SSCC, the rule is that an individual SSCC number must not be reallocated within one year of the shipment date from the SSCC assignor to a trading partner. However, prevailing regulatory or industry organization specific requirements may extend this period.

## 4.5. Allocating GS1 System Asset Identifiers

### 4.5.1. General Rule

#### 4.5.1.1. GS1 System Asset Identifiers

GS1 System asset identifiers can be used to identify any fixed assets of a company. It is left to the discretion of the issuer to determine whether the Global Returnable Asset Identifier (GRAI), AI (8003), or Global Individual Asset Identifier (GIAI), AI (8004), is more suitable for the application concerned.

#### 4.5.1.2. Uniqueness of Asset Identifiers

Asset identifiers must not be used for any other purpose and must remain unique for a period well beyond the lifetime of the relevant records. If a company assigns asset identifiers to trade items supplied to its customers, the company must ensure that the asset identifiers are never re-used.

#### 4.5.1.3. Best Practice

Best practices may dictate that the trade item manufacturer apply the asset identifier during the manufacturing process. This number may then be used for ordering new assets of an identical type

#### 4.5.1.4. Allocating Global Returnable Asset Identifiers (GRAIs): AI (8003)

The structure of the Element String for a Global Returnable Asset Identifier (GRAI) can include two parts: the mandatory Identification of an Asset Type and an optional serial number, to distinguish individual assets within the same asset type (see Section 2.).

Figure 4.5.1.4 – 1

Format of the Element String				
Application Identifier	Global Returnable Asset Identifier (GRAI)			
	GS1 Company Prefix	Asset Type	Check Digit	Serial Number (Optional)
8 0 0 3	0 N <sub>1</sub> N <sub>2</sub> N <sub>3</sub> N <sub>4</sub> N <sub>5</sub> N <sub>6</sub> N <sub>7</sub> N <sub>8</sub> N <sub>9</sub> N <sub>10</sub> N <sub>11</sub> N <sub>12</sub>		N <sub>13</sub>	X <sub>1</sub> variable X <sub>16</sub>

The exact method used to allocate the GRAI is left to the discretion of the issuing organisation. However, a unique number, the Asset Type, must be assigned for each type of asset being identified, and for ease of administration, the GS1 System recommends that numbers be allocated sequentially and not contain classifying elements.

When it is not possible to assign an Asset Type (e.g., for museum exhibits), or when the type of asset is not required by the application (e.g., when the item is only used for a single type of asset), then the Global Individual Asset Identifier (GIAI), AI (8004), should be used.

To encode the following Examples of Identification Numbers in a GS1-128 Bar Code Symbol a zero in the leftmost position must be added to generate the defined length for the 14-digit asset identification number field.

#### 4.5.1.5. Identical Assets Identification

A single Global Returnable Asset Identifier (GRAI) should be assigned to a series of identical assets.

Figure 4.5.1.5 – 1

Asset Type	GRAI
50 litre aluminium beer keg	1234567890005
10 litre aluminium beer keg	1234567890012
10 litre wooden beer keg	1234567890029

#### 4.5.1.6. Serial Number (Optional)

The owner of the asset assigns the optional serial number. It denotes an individual asset within a given Asset Type. The field is alphanumeric and is used to distinguish individual assets with the same Asset Types.

Figure 4.5.1.6 – 1

Asset Type	GRAI (incl. the Serial Number)
50 litre aluminium beer keg	12345678900051234AX01
50 litre aluminium beer keg	12345678900051234AX02
50 litre aluminium beer keg	12345678900051234AX03

#### 4.5.1.7. Allocating Global Individual Asset Identifiers (GIAs): AI (8004)

The Global Individual Asset Identifier (GIAI) is structured according to Figure 4.6.1.7 - 1.

Figure 4.5.1.7 - 1

Format of the Element String	
Application Identifier	Global Individual Asset Identifier (GIAI)
	<div style="display: flex; justify-content: space-between; align-items: center;"> <div style="text-align: center;"> <p>GS1 Company Prefix</p> <p>→</p> </div> <div style="text-align: center;"> <p>Individual Asset Reference</p> <p>→</p> </div> </div>
8 0 0 4	$N_1 \dots N_i \quad X_{i+1} \dots \text{variable length} \quad X_j \text{ (} j \leq 30 \text{)}$

The exact method used to allocate the GIAI is left to the discretion of the issuing organisation. However, each GIAI must be unique for each individual asset being identified and, for ease of administration, the GS1 System recommends that GIAs be allocated sequentially and not contain classifying elements.

#### 4.5.2. Change of Asset Ownership

Asset identification numbers are used in a diverse range of business applications ranging from tracking the movements of re-usable packaging trays to recording the life-cycle history of aircraft parts. If a company sells an asset to another company then the asset identifier should ideally be replaced by another Global Individual Asset Identifier (GIAI) or Global Returnable Asset Identifier (GRAI) or be removed. It is permissible for the asset identifier to remain on the item when the ownership changes if the new owner takes responsibility for the GS1 Company Prefix associated with the asset identifier.

For further information regarding changes of ownership, please refer to Section 1.5.

### 4.5.3. Information Associated with Asset Identifiers

The attributes of the asset should be established on a computer file using the GS1 System asset identifier as the key to the information. Examples of the type of information held include the full name and address of the party who owns the asset, the value of the asset, the location of the asset, and the life-cycle history of the asset.

## 4.6. GLN Rules

### 4.6.1. Allocating Global Location Numbers

#### 4.6.1.1. General Rule

Global Location Numbers (GLNs) can be used to identify any physical location or legal entity that has meaning within a business scenario. The general rule is that a separate GLN is required to identify each different location (e.g., each store of a retail group is required to have a separate GLN to enable efficient delivery to the individual store).

The exact method used to allocate the GLN is at the discretion of the issuing organisation. In line with best practice, GS1 recommends that the GLN be assigned at source, usually by the party owning the location. When a new GLN is issued, it is recommended that:

- The GLN be associated with the master data for the identified location
- This master data be communicated to trading partners in a timely manner
- GLNs be allocated sequentially without classifying elements

Once assigned at the source, usually by the party owning the location, the GLN becomes a global reference that can be used by all. See Section [4.6.1.6](#), for guidance on trading with organisations that do not use GLNs.

The GLN allocated to an entity should be communicated from the owner of the location through the supply chain in advance of a transaction/delivery so that all systems can be prepared for interaction. GLNs are reference keys for retrieving the indicated information from databases.

From time to time, the details (associated data) related to a GLN might change. The following subsections are general cases or examples on the allocation of GLNs due to a change in the circumstances or business conditions in which the number was originally established. See Section [4.6.3](#) or GLN allocation rules and scenarios regarding when GLNs should remain the same or should be changed. These rules are based on business practices.

- ✔ **Note:** National, federal, or local regulations may take precedence over this guideline. Examples include regulations affecting a company's registration, taxation, or fiscal obligations, as well as its industry requirements.

#### 4.6.1.2. Company Liquidation, Acquisition, and Mergers: Change of Ownership

If a company sells a location to another party who may or may not be using Global Location Numbers (GLNs), the GLN for the address that is associated with the previous owner should be closed. If the new owner of the address wishes to identify the location with a GLN, a new number should be assigned using the new owner's GS1 Company Prefix. In this scenario, the new owner should assign a new GLN within one year of purchase.

- If a company sells a location to another party, the GLN that was assigned should not be reassigned per the provisions of Section [4.6.1.7](#).
- If the purchase of the whole company by another has included assignment of the GS1 Company Prefix with the consent of the Member Organisation, then the existing GLNs already allocated can continue to be used.
- If a company is split as a result of the purchase, the new owner must assign new GLNs.

In addition, if two activities within a company merge and have separate GLNs before the merger, then transition to one of the existing GLNs should be made by updating records and retiring one of the GLNs.

#### **4.6.1.3. Relocations**

Relocations within the same building (e.g., a department moves from the second to the seventh floor of a building), or other changes in address that have little or no impact on such things as deliveries and payments, do not require assignment of a new GLN. The changed information may be updated and communicated to trading partners. However, whenever the point of access changes, a new GLN should be assigned.

When a given operation is closed in one location and replaced by a similar operation at a new location, a new GLN should be assigned.

#### **4.6.1.4. Physical Location, Ownership Remain Unchanged; Associated Data for a Particular GLN Change**

If an attribute associated with a Global Location Number (GLN) changes (e.g., a cross-docking station changes within a warehouse or a small enterprise starts electronic invoicing), the details associated with the GLN should be communicated to trading partners by the party responsible for the location. The GLN itself remains the same.

#### **4.6.1.5. Grouping of Global Location Numbers**

While GS1 user companies, for their internal purposes, may group Global Location Numbers (GLNs) into some logical grouping, there are currently no supply chain standards to do so. GLNs are assigned at the discretion of GS1 user companies to support their business applications. The principle of Non-Significance (see Section 1.) is critical to supply chain use, and it therefore follows that any additions or deletions from the group do not impact individual GLN assignment.

#### **4.6.1.6. Trading Partners without Global Location Numbers**

Trading partners without a Global Location Number who are responsible for a given location must request a GLN from their local GS1 Member Organisation. Assigning the GLN at source by the responsible trading partner ensures supply chain efficiency. A GLN cannot be sold, leased, or loaned to a separate legal entity.

#### **4.6.1.7. Reassignment of Global Location Numbers**

A Global Location Number (GLN) that has been previously used or has become obsolete must not be reused for another location until at least 48 months have elapsed. A longer period may be needed in accordance with government requirements, such as invoicing and taxation, or requirements related to the nature of the location (e.g., a bonded warehouse). This period must allow time for all references of the old GLN to be removed from trading partners' files.

## 4.6.2. Information Associated with a Global Location Number

Master data for a location should be established on a computer file and the Global Location Number (GLN) may then be used to facilitate efficient communication of this information. There are a number of solution providers who provide services for the efficient communication of master data information associated with a GLN on a global or regional level.

An example of the type of information held includes the full name and address of the party, bank details and account number, sales department that deals with the party, and profile of a company.

Information associated with each GLN is held internally by trading partners or on central databases. If the location changes and the details are not changed, communications or deliveries will go to the address held on file. It is, therefore, essential for organisations to keep trading partners informed of any change of information associated with a GLN. See Section [4.6.3](#) for GLN allocation rules and scenarios where changes to a location or attributes relating to a GLN may require a new GLN.

Within the GS1 System, the GLN and the Global Trade Item Number (GTIN) are two distinct data identifiers. There is no conflict when a GTIN and a GLN have the same digits, as the data carrier (electronic data interchange, machine readable symbol, or radio frequency) will distinguish between the two identifiers. For example, when GLNs are used in Automatic Identification and Data Capture (AIDC) and EDI, the context (Application Identifiers and qualifiers) will prevent any misinterpretation.

## 4.6.3. GLN Allocation Rules

The GLN Allocation Rules (<http://www.gs1.org/glnrules>) was developed by the Global Location Number (GLN) Allocation Rules Work Group established under Global Standards Management Process (GSMP). The starting point for each of the scenarios listed is a correctly assigned GLN according to the general rules described in Section [4.6.1](#).

GLNs are assigned to physical and legal locations to provide a key to access master data in a business process (e.g., order, invoice, deliver). For each of these assigned GLNs, master data will be assigned to the GLN to support the business process. The scenarios <http://www.gs1.org/glnrules> illustrate a change in the business process or attribute data associated with a given GLN and indicate whether a new GLN should be assigned to signify the change or whether alternative business processes (e.g., change to the PARTIN (Party Information) message in business messaging or updating information in a Party Data Catalogue) can be used to communicate the GLN change.

GLNs are intended to support business processes and are used to identify entities and organisations. Individual businesses need to determine whether to use the same GLN for more than one business process (e.g., a small business may use a single GLN for order, delivery, and invoice, because each of these processes are undertaken in a single location, while a multinational organisation could choose to assign a distinct GLN to each location within its organisation).

The GLN Allocation Rules can be found at <http://www.gs1.org/glnrules>.



**Note:** These rules are intended for global use. Exceptions may occur only when local regulatory or legal requirements mandate otherwise.

## 4.7. GSRN Rules

### 4.7.1. Allocating Global Service Relation Numbers

### 4.7.2. General Rule

The Global Service Relation Number (GSRN) can be used to identify any service relationship. A separate, unique number can be issued, normally by the service provider, to identify any given service

relationship. Once assigned, the GSRN becomes a unique and universal reference that can be used by all parties involved in the service relationship.

#### 4.7.2.1. Changes in a Service Relationship

From time to time the details related to a Global Service Relation Number (GSRN) may change. The following are general cases that may occur if the circumstances under which the GSRN was originally set up change:

- If a service provider ceases trading (possibly because of liquidation), any GSRNs allocated by that organisation should be phased out. If the activity covered by the GSRN is transferred, the new service provider may continue to use existing GSRNs, but should allocate further GSRNs using the new provider's GS1 Company Prefix.
- If the range of services identified by a GSRN changes, the service provider should change the details associated with the GSRN on the related computer file record. The assignment of a new GSRN is not required in this case.
- A GSRN used to identify a particular service relationship that has terminated should not be reallocated for a period well beyond the lifetime of the relevant records.

#### 4.7.2.2. Recommendation for Allocating Global Service Relation Numbers

The exact method used to allocate the Global Service Relation Number (GSRN) is left to the discretion of the issuing organisation. However, the GSRN must be unique for each individual service recipient and remain unique for a period well beyond the lifetime of the records relevant to the service relationship.

For ease of administration, GS1 recommends that GSRNs be allocated sequentially and not contain classifying elements.

#### 4.7.2.3. Information Associated with a Global Service Relation Number

The Global Service Relation Number (GSRN) is a standalone Element String. All information required by the service provider should be established on a computer file using the GSRN as the key to access the information. The type of information stored is determined by the nature of the service relationship. Typical information includes the service recipient's full name, address, and details on services rendered.

## 4.8. GDTI Rules

### 4.8.1. Application Rules

#### 4.8.1.1. Definition of a Document Requiring Internal Control

The term *document* is applied broadly to cover any official or private papers that infer a right (e.g., proof of ownership) or obligation (e.g., notification of a call for military service) upon the bearer. The issuer of the document is normally responsible for all the information contained upon the document (both bar coded and human readable). Such documents typically require storage of the appropriate information contained on the document. Examples include:

- Land registration papers
- Tax demands
- Proof of shipment/receipt forms

- Custom's clearance forms
- Insurance policies
- Internal invoices
- National press documents
- Educational papers
- Transporting company documents
- Mail companies documents

#### 4.8.1.2. Bar Code Symbology

The GS1-128 Bar Code Symbol is used for Documents that require control. The bar code in no way replaces the need for Human Readable information.

#### 4.8.1.3. Bar Code Information

##### 4.8.1.3.1. Symbol Requirements

To facilitate efficient scanning, all bar code symbols shall be printed at an X-dimension between 0.25 millimetre (0.00984 inch) and 0.495 millimetre (0.0195 inch) and be a minimum of 13 millimetres (0.5 inch) in height.

The information required for the internal control of documents should be carried by GS1-128 Bar Code Symbols.

##### 4.8.1.3.2. Global Document Type Identifier (GDTI)

The Application Identifier to indicate the Global Document Type Identifier is AI (253).

The Global Document Type Identifier (GDTI) is assigned by the document issuer. The GDTI is used as a key to access database information that is required for document control purposes (normally held by issuing organisation). The same Document Type is used for all document classes that are issued with an identical purpose. This can then be used to reference the characteristics of the document, such as:

- The issuer of the document
- The exact right or obligation the document imposes
- The document type (e.g., insurance policy, governmental paper)

A different Document Type shall be used whenever characteristics of the document are different.

By their nature, each document needs to be individually tailored for the intended recipient and, therefore, requires a unique reference number in addition to the Document Type. Any duplicates of a document should use the same number as the original. The serial component is optional and assigned by the document issuer and is a unique number in a series of documents issued under the same Document Type. Ideally the serial component should be sequentially allocated for each new document generated.

The serial component is used to communicate exact details pertinent to the individual document such as:

- The name and address of the recipient
- The cross-reference to individual details

## 4.9. Data Relationships

The Element Strings that require specialised software and/or scanner set up are not covered by these rules. These are the Element Strings with GS1 Prefixes 0001 to 0007, 02, 04, 05, 20 to 29, 98, and 99; GTIN-8 Prefixes 0 and 2; two-digit and five-digit Add-On Symbols; and AIs (8100) to (8102).

Duplicate Element Strings appearing on the same physical entity must have the same value.

In Figures 4.9.1 - 1 and 4.9.2 - 1, the Application Identifiers (AIs) are used to indicate the Element String. The AI (01) is used to indicate a Global Trade Item Number (GTIN); however, the Element Strings that encode GTINs are defined in Section 3. GTINs may be encoded in bar code symbols from the EAN/UPC Symbology family, ITF-14 Bar Code Symbols, GS1 DataBar (RSS) Symbology family, GS1 DataMatrix and GS1-128 Bar Code Symbols using AI (01) or AI (8006).

### 4.9.1. Invalid Pairs of Element Strings

This section defines the pairs of Element Strings that cannot appear on the same physical entity.

Figure 4.9.1 – 1

Pair of Element Strings				Comment
AI	Designation	AI	Designation	
01	Identification of a trade item	01	Identification of a trade item	Duplicate Global Trade Item Numbers (GTINs) with different values
01	Identification of a trade item	02	Identification of logistic unit contents	AI (02) must not be used for the identification of trade items contained in a trade item.
01	Identification of a trade item	37	Count of units contained	The count of units contained would duplicate the master data of the GTIN. AI (37) may only be used with AI (02).
22	Secondary data for the health industry	30	Count	Duplicate counts with different values
22	Secondary data for the health industry	10	Batch/lot number	Duplicate lot numbers with different values
22	Secondary data for the health industry	17	Expiration date	Duplicate expiration date with different values
22	Secondary data for the health industry	21	Serial number	Duplicate serial numbers with different values
242	Made-to-Order Variation	01 or 02 with N <sub>1</sub> not equal to 9	Identification of a Variable Measure Trade Item	Made-to-Order Variation can only be used with a GTIN-14, Indicator digit 9. This represents a Custom Industrial Supply Item
420	Ship to postal code, single postal authority	421	Ship to postal code with ISO country code	Only one ship to postal code may be applied on an item
422	Country of origin of a trade item	426	Country of full processing	Duplication of country of origin of a trade item (covered by country of full processing)
423	Country of initial processing	426	Country of full processing	Duplication of country of initial processing (covered by country of full processing)

Pair of Element Strings				Comment
AI	Designation	AI	Designation	
424	Country of processing	426	Country of full processing	Duplication of country of processing (covered by country of full processing)
425	Country of disassembly	426	Country of full processing	Duplication of country of disassembly (covered by country of full processing)
390n	Amount payable – single monetary area	391n	Amount payable – with ISO currency code	Only one amount payable Element String may be applied on a payment slip
392n	Amount Payable for a Variable Measure Trade Item – Single Monetary Area	393n	Amount Payable for a Variable Measure Trade Item and ISO Currency Code	Only one amount payable Element String may be applied on a Variable Measure Trade Item.
8006	Component identification	01	Identification of a trade item	Other GTINs cannot be used with AI (8006). The trade item is identified by a GTIN contained in the AI (8006).

#### 4.9.2. Mandatory Association of Element Strings

This section defines the Element Strings that mandate the appearance of another Element String on the same physical entity.

Figure 4.9.2 – 1

If Element String		Then Mandatory Associated Element String	Comment
AI	Designation		
01 or 02 with N <sub>1</sub> = 9	Identification of a Variable Measure Trade Item	30, 3nnn <sup>1</sup> or 3nnn <sup>2</sup> or 8001	Mandatory association with variable measure information Only GS1-128, ITF-14, and GS1 DataBar Expanded Bar Code Symbols can encode a GTIN with N <sub>1</sub> = 9.
02	Identification of logistic unit contents	00	Mandatory association with an SSCC (Serial Shipping Container Code)
02	Identification of logistic unit contents	37	Mandatory count of the contained trade items
10	Batch/lot number	01 or 02	Mandatory association with a Global Trade Item Number (GTIN) or with the identification of logistic unit contents
11, 13, 15, 17	Dates	01 or 02	Mandatory association with a GTIN or with the identification of logistic unit contents
12	Due date	8020 and 415	Mandatory association with the payment slip reference number (AI (8020)) and the Global Location Number (GLN) of the invoicing party
20	Product variant	01 or 02	Mandatory association with a GTIN or with the identification of logistic unit contents

If Element String		Then Mandatory Associated Element String	Comment
21	Serial number	01	Mandatory association with a GTIN of a single trade item (a serial number cannot apply to a grouping of trade items)
22	Secondary data health industry	01	Mandatory association with a GTIN
240	Additional product identification	01 or 02	Mandatory association with a GTIN or with the identification of logistic unit contents
241	Customer part number	01 or 02	Mandatory association with a GTIN or with the identification of logistic unit contents
242	Made-to-Order Variation Number	01 or 02 with $N_1 = 9$	Mandatory association with a GTIN-14 with Indicator Digit 9 represents a Custom Industrial Supply Item
250	Secondary serial number	01	Mandatory association with a GTIN (a secondary serial number cannot apply to a grouping of trade items)
251	Reference to source entity	01	Mandatory association with GTIN of the trade item
254	Extension component of a GLN	414	Mandatory association with AI (414). Only GS1-128, GS1 DataBar Expanded symbologies, and EPC RFID tags are valid. This is used with GLN and not GTIN.
30	Variable count	01 or 02	Mandatory association with a variable measure GTIN (e.g., a GTIN-14 starting with the digit 9) or the identification of variable measure content of a logistic unit
3nnn*	Trade measures that cannot be summed	01	Mandatory association with a variable measure GTIN (e.g., a GTIN-14 starting with the digit 9)
3nnn**	Trade measures that can be summed	01 or 02	Mandatory association with a variable measure GTIN (e.g., a GTIN-14 starting with the digit 9) or the identification of variable measure content of a logistic unit
3nnn***	Logistic measures	00 or 01	Mandatory association with an SSCC or a variable measure GTIN (e.g., a GTIN-14 starting with the digit 9)
337n	Kilograms per square metre	01	Mandatory association with a GTIN
37	Count of units contained	02	Mandatory association with the identification of logistic unit contents
390n	Amount payable – single monetary area	8020 and 415	Mandatory association with the payment slip reference number, AI (8020), and the GLN of the invoicing party
391n	Amount payable – with ISO currency code	8020 and 415	Mandatory association with the payment slip reference number, AI (8020), and the GLN of the invoicing party
392n	Amount payable – single monetary unit	01	Mandatory association with variable measure GTIN (e.g., a GTIN-14 starting with the digit 9)

If Element String		Then Mandatory Associated Element String	Comment
393n	Amount payable – with ISO currency code	01	Mandatory association with variable measure GTIN (e.g., a GTIN-14 starting with the digit 9)
403	Routing code	00	Mandatory association with an SSCC
415	GLN of the invoicing party	8020	Mandatory association with payment slip reference number, AI (8020)
422	Country of origin	01 or 02	Mandatory association with a GTIN
423	Country of initial processing	01 or 02	Mandatory association with a GTIN or with the identification of logistic unit contents
424	Country of processing	01 or 02	Mandatory association with a GTIN or with the identification of logistic unit contents
425	Country of disassembly	01 or 02	Mandatory association with a GTIN or with the identification of logistic unit contents
426	Country of full processing	01 or 02	Mandatory association with a GTIN or with the identification of logistic unit contents
7001	NATO stock number	01 or 02	Mandatory association with a GTIN or with the identification of logistic unit contents
7002	UN/ECE meat carcasses and cuts classification	01 or 02	Mandatory association with a GTIN or with the identification of logistic unit contents
703(s)	Approval number of processor	01 or 02	Mandatory association with a GTIN or with the identification of logistic unit contents
8001	Variables of roll products	01	Mandatory association with a variable measure GTIN (e.g., an GTIN-14 starting with the digit 9)
8005	Price per unit of measure	01 or 02 with N <sub>1</sub> = 9	Mandatory association with a variable measure GTIN or the identification of variable measure content of a logistic unit
8007	International Bank Account Number, AI (8007)	8020 and 415	Mandatory association with the payment slip reference number, AI (8020), and the GLN of the invoicing party
8008	Date and time of production	01 or 02	Mandatory association with a GTIN or with the identification of logistic unit contents
8020	Payment slip reference number, AI (8020)	415	Mandatory association with the GLN of the invoicing party

**Notes:**

- \* Is (3nnn) where the first three digits are 312, 313, 324, 325, 326, 327, 328, and 329
- \*\* Is (3nnn) where the first three digits are 310, 311, 314, 315, 316, 320, 321, 322, 323, 350, 351, 352, 356, 357, 360, 361, 364, 365, and 366
- \*\*\* Is (3nnn) where the first three digits are 330, 331, 332, 333, 334, 335, 336, 340, 341, 342, 343, 344, 345, 346, 347, 348, 349, 353, 354, 355, 362, 363, 367, 368, and 369



## Section 5. Data Carriers

- Introduction
- Linear Bar Codes - EAN/UPC Symbology Specifications
- Linear Bar Codes - ITF-14 Symbology Specifications
- Linear Bar Codes - GS1-128 Symbology Specifications
- Bar Code Production and Quality Assessment
- Linear Bar Codes – GS1 DataBar
- Two Dimensional Bar Codes – GS1 DataMatrix Symbology
- Composite Bar Codes
- Appendix: Rules for Encoding/Decoding Element Strings in GS1 Symbologies using GS1 Application Identifiers

Whilst every effort has been made to ensure that the guidelines to use the GS1 standards contained in the document are correct, GS1 and any other party involved in the creation of the document HEREBY STATE that the document is provided without warranty, either expressed or implied, of accuracy or fitness for purpose, AND HEREBY DISCLAIM any liability, direct or indirect, for damages or loss relating to the use of the document. The document may be modified, subject to developments in technology, changes to the standards, or new legal requirements.

Several products and company names mentioned herein may be trademarks and/or registered trademarks of their respective companies.

## 5.1. Introduction

A data carrier is a means of representing data in machine readable form. Data carriers that are endorsed by GS1 are described in Sections [5.1](#), [5.2](#), [5.3](#), [5.4](#), [5.6](#), [5.7](#) and [5.8](#) and bar code production and quality assessment are covered in Section [5.5](#).

The GS1 System specifies the data carrier used to represent any given Element String. Section 2 covers rules indicating which data carrier should be used to represent which Element Strings in particular applications.

The GS1 System uses the following data carriers:

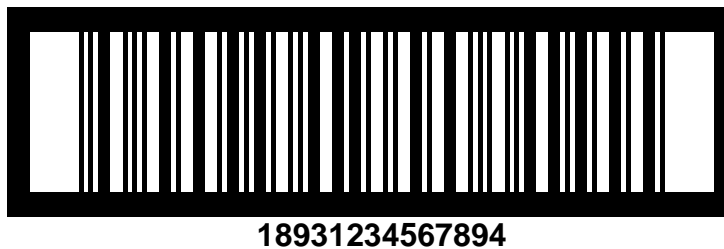
- The EAN/UPC Symbology family of bar code symbols (UPC-A, UPC-E, EAN-13, and EAN-8 Bar Code Symbols and the two- and five-digit Add-On Symbols) can be read omnidirectionally. These symbols must be used for all items that are scanned at the Point-of-Sale and may be used on other trade items.

Figure 5.1 - 1



- ITF-14 (Interleaved 2-of-5) Bar Code Symbols carry ID numbers only on trade items that are not expected to pass through the Point-of-Sale. ITF-14 Symbols are better suited for direct printing onto corrugated fibreboard.

Figure 5.1 - 2



- The GS1-128 Bar Code Symbol is a subset of the Code 128 Bar Code Symbology. Its use is exclusively licensed to GS1. This extremely flexible symbology encodes Element Strings using Application Identifiers.

Figure 5.1 - 3



- GS1 DataBar (formerly RSS) is a family of linear symbologies used within the GS1 System. This family of linear symbologies in most cases implicitly encodes Application Identifier (01) and in the case of GS1 DataBar Expanded (formerly RSS Expanded) explicitly encodes Element Strings using Application Identifiers.

Figure 5.1 - 4



(01)20012345678909

- Composite Component Symbols do not exist in isolation. The primary identification number is always encoded in the linear symbol and supplementary Application Identifier Element Strings may be encoded in the two-dimensional (2D) component where they take up less space.

Figure 5.1 - 5

(17)050101(10)ABC123



(01)04012345678901

- Data Matrix ISO version ECC 200 is the only version that supports GS1 System data structures, including Function 1 Symbol Character. Implementation of GS1 DataMatrix shall be done per approved GS1 System application guidelines, such as those for very small healthcare items.

Figure 5.1 - 6

(21) ABCDEFG123456789



(01) 04012345678901

### 5.1.1. International Standards

A number of national and regional standardisation bodies have developed bar code symbol technical standards. The International Standards Organisation (ISO) has published standard bar code symbology specifications via a subcommittee of ISO/IEC JTC1 (International Standards Organisation/International Electronics Committee Joint Technical Committee 1).

GS1 is actively involved in developing these standards. The objective is for GS1 System standards to remain fully compatible with relevant published national, regional, and international symbology standards. The pertinent documents for Section 5 include the latest published version of:

- **Section 5.1:** ISO/IEC 15424: Information technology; automatic identification and data capture techniques; data carrier/symbology identifiers


- **Section 5.2:** ISO/IEC 15420: Information technology; automatic identification and data capture techniques; bar code symbology specifications; EAN/UPC
- **Section 5.3:** ISO/IEC 16390: Information technology; automatic identification and data capture techniques; bar code symbology specifications; ITF-14
- **Section 5.4:** ISO/IEC 15417: Information technology; automatic identification and data capture techniques; bar code symbology specifications; GS1-128 Symbology specifications
- **Section 5.5:** Bar Code Production and Quality Assessment
  - ISO/IEC 15415: Information technology; automatic identification and data capture techniques; bar code print quality test specification; two-dimensional symbols
  - ISO/IEC 15416: Information technology; automatic identification and data capture techniques; bar code print quality test specification; linear symbols
  - ISO/IEC 15419: Information technology; automatic identification and data capture techniques; bar code digital imaging and printing performance testing
  - ISO/IEC 15421: Information technology; automatic identification and data capture techniques; bar code master test specifications
  - ISO/IEC 15426-1: Information technology; automatic identification and data capture techniques; bar code verifier conformance specification - Part 1: Linear symbols
- **Section 5.6:** ISO/IEC 24724: Information technology; automatic identification and data capture techniques; Reduced Space Symbology (RSS) bar code symbology specification (formerly RSS; now GS1 DataBar)
- **Section 5.7:** ISO/IEC 16022: Information technology; automatic identification and data capture techniques; Data Matrix bar code symbology specification
- **Section 5.8:** ISO/IEC 24723: Information technology; automatic identification and data capture techniques; EAN.UCC Composite bar code symbology specification

### 5.1.2. Symbology Identifiers

The symbology identifier is not encoded in the bar code symbol, but is generated by the decoder after decoding and is transmitted as a preamble to the data message.

All scanning equipment has the ability to recognise the symbology that has been scanned. Some scanners have the optional feature of being able to transmit a symbology identifier. The symbology identifier is a three-character data string comprising a flag character, code character, and a modifier character.

Character	Description
<b>] </b>	The flag character (which has an ASCII value of 93). This denotes that the two characters following it are Symbol Identifier characters.
<b>c</b>	The code character. This denotes the type of symbology.
<b>m</b>	The modifier character. This indicates the mode in which the symbology is used.

 **Note:** If used, the symbology identifier is transmitted as a prefix to the data message.

The symbology identifiers used in the GS1 System are shown in Figure 5.1.2 - 1.

Figure 5.1.2 - 1

Symbology Identifier*	Symbology Format	Content
] E 0	EAN-13, UPC-A, or UPC-E	13 digits
] E 1	Two-digit Add-On Symbol	2 digits
] E 2	Five-digit Add-On Symbol	5 digits
] E 3	EAN-13, UPC-A, or UPC-E with Add-On Symbol**	15 or 18 digits
] E 4	EAN-8	8 digits
] I 1	ITF-14	14 digits
] C 1	GS1-128	Standard AI Element Strings
] e 0	GS1 DataBar***	Standard AI Element Strings
] d 2	GS1 DataMatrix	Standard AI Element Strings

**Notes:**

- \* Symbology identifiers are case sensitive.
- \*\* Bar code symbols with Add-On Symbols may be considered either as two separate symbols, each of which is transmitted separately with its own symbology identifier, or as a single data packet. The system designer shall select one of these methods, but the method using symbology identifier ]E3 is preferable for data security.
- \*\*\* The GS1 DataBar Symbology has several symbol types, and the full list of modifier characters is found in Section 5.6.

## 5.2. Linear Bar Codes - EAN/UPC Symbology Specifications

### 5.2.1. EAN/UPC Symbology Specifications

### 5.2.2. Symbology Characteristics

Characteristics of bar code symbols in the EAN/UPC Symbology family include:

- Numeric encodable character set (0 to 9) (e.g., ASCII characters 48 to 57 inclusive, in accordance with ISO/IEC 646: Information technology; ISO 7-bit coded character set for information interchange)
- Symbology type: continuous
- Symbol character density: seven modules per symbol character
- Four elements per symbol character comprising two bars (dark bars) and two spaces (light bars), each of one, two, three, or four modules in width (auxiliary guard patterns have differing numbers of elements)
- Character self-checking
- Fixed data string length encodable: 8, 12, or 13 characters including Check Digit, depending on specific symbol type
- Omni-directionally decodable
- One mandatory Check Digit (described in Section 7.10)
- Non-data overhead not including the Check Digit or Quiet Zones:

- 11 modules for EAN-13, EAN-8, and UPC-A Bar Code Symbols (left Guard Bar Pattern/centre Guard Bar Pattern/right Guard Bar Pattern)
- Nine modules for UPC-E Bar Code Symbols (left Guard Bar Pattern/right Guard Bar Pattern)

### 5.2.2.1. Symbol Types

The bar code symbols in the EAN/UPC Symbology family are:

- EAN-13, UPC-A, and UPC-E Bar Code Symbols, all of which may be accompanied by an Add-On Symbol
- EAN-8 Bar Code Symbols

The four symbol types are described in Sections [5.2.2.3.1](#), [5.2.2.3.2](#), [5.2.2.3.3](#), and [5.2.2.3.4](#), and the optional Add-On Symbols are described in Section [5.2.2.3.5](#).

### 5.2.2.2. Symbol Encodation

#### 5.2.2.2.1. Symbol Character Encodation

Symbol characters shall encode digit values in seven module characters selected from different number sets known as A, B, and C as shown in Figure 5.2.2.2.1 - 1.

Figure 5.2.2.2.1 - 1 Number Sets A, B, and C

Digit Value	Set A Element Widths				Set B Element Widths				Set C Element Widths			
	S	B	S	B	S	B	S	B	B	S	B	S
0	3	2	1	1	1	1	2	3	3	2	1	1
1	2	2	2	1	1	2	2	2	2	2	2	1
2	2	1	2	2	2	2	1	2	2	1	2	2
3	1	4	1	1	1	1	4	1	1	4	1	1
4	1	1	3	2	2	3	1	1	1	1	3	2
5	1	2	3	1	1	3	2	1	1	2	3	1
6	1	1	1	4	4	1	1	1	1	1	1	4
7	1	3	1	2	2	1	3	1	1	3	1	2
8	1	2	1	3	3	1	2	1	1	2	1	3
9	3	1	1	2	2	1	1	3	3	1	1	2

**Note:** **S** denotes a space (light bar), **B** denotes a bar (dark bar), and the element widths are in modules.

Figure 5.2.4.1 - 1 graphically illustrates Figure 5.2.2.2.1 - 1. The sum of the bar (dark bar) modules in any symbol character determines its parity. Symbol characters in number set A are odd parity characters. Symbol characters in number sets B and C are even parity characters. Number set C characters are mirror images of number set B characters.

Symbol characters in number sets A and B always begin on the left with a space module and end on the right with a dark module. Symbol characters in number set C begin on the left with a dark module and end on the right with a light module.

A data character shall normally be represented by a symbol character. However, in certain specific instances defined in Sections [5.2.2.3.1](#), [5.2.2.3.4](#), and [5.2.2.3.5](#), the combination of number sets in a symbol may itself represent either data or a Check Digit value. This technique is referred to as variable parity encodation.

### 5.2.2.2.2. Auxiliary Pattern Encodation

Auxiliary patterns shall be composed as shown in Figure 5.2.2.2.2 - 1.

Figure 5.2.2.2.2 - 1 Auxiliary Patterns

Auxiliary Pattern	Number of Modules	Element Widths in Modules					
		S	B	S	B	S	B
Normal Guard Bar Pattern	3		1	1	1		
Centre Guard Bar Pattern	5	1	1	1	1	1	
Special Guard Bar Pattern	6	1	1	1	1	1	1
Add-On Guard Bar Pattern	4		1	1	2		
Add-On Delineator	2	1	1				

**Note:** **S** denotes a space (light) element and **B** denotes a bar (dark) element.

Section [5.2.4.2](#) graphically illustrates these patterns.

The normal Guard Bar Pattern corresponds to the start and stop patterns in other symbologies, and the special Guard Bar Pattern is used as a stop pattern in UPC-E Bar Code Symbols.

### 5.2.2.3. Symbol Formats

#### 5.2.2.3.1. EAN-13 Bar Code Symbols

The EAN-13 Bar Code Symbol shall be made up as follows, reading from left to right:

- A left Quiet Zone
- A normal Guard Bar Pattern
- Six symbol characters from number sets A and B
- A centre Guard Bar Pattern
- Six symbol characters from number set C
- A normal Guard Bar Pattern
- A right Quiet Zone

The rightmost symbol character shall encode the Check Digit calculated in accordance with Section 7.10.

Since the EAN-13 Bar Code Symbol comprises only 12 symbol characters but encodes 13 digits of data (including the Check Digit), the value of the additional digit, which is the character in the leftmost position in the data string, shall be encoded by the variable parity mix of number sets A and B for the six symbol characters in the left half of the symbol. The numbering system for values of the leading digit is specified in Figure 5.2.2.3.1 - 1. Figure 5.2.2.3.1 - 2 is an example of an EAN-13 Bar Code Symbol.

**Figure 5.2.2.3.1 – 1 Left Half of an EAN-13 Bar Code Symbol**

Leading Digit, Implicitly Encoded	Number Sets Used for Numbering Left Half of an EAN-13 Bar Code Symbol					
	Symbol Character Position					
	1	2	3	4	5	6
0*	A	A	A	A	A	A
1	A	A	B	A	B	B
2	A	A	B	B	A	B
3	A	A	B	B	B	A
4	A	B	A	A	B	B
5	A	B	B	A	A	B
6	A	B	B	B	A	A
7	A	B	A	B	A	B
8	A	B	A	B	B	A
9	A	B	B	A	B	A

**Note:** The leading digit value “0” is reserved for symbols encoding GTIN-12 Element Strings.

**Figure 5.2.2.3.1 – 2 EAN-13 Bar Code Symbol**



### 5.2.2.3.2. EAN-8 Bar Code Symbols

The EAN-8 Bar Code Symbol shall be made up as follows, reading from left to right:

- A left Quiet Zone
- A normal Guard Bar Pattern
- Four symbol characters from number set A
- A centre Guard Bar Pattern
- Four symbol characters from number set C
- A normal Guard Bar Pattern
- A right Quiet Zone

The rightmost symbol character shall encode the Check Digit calculated in accordance with Section 7.10. Figure 5.2.2.3.2 - 1 is an example of an EAN-8 Bar Code Symbol.

**Figure 5.2.2.3.2 – 1 EAN-8 Bar Code Symbol**

### 5.2.2.3.3. UPC-A Bar Code Symbols

The UPC-A Bar Code Symbol shall be made up as follows, reading from left to right:

- A left Quiet Zone
- A normal Guard Bar Pattern
- Six symbol characters from number set A
- A centre Guard Bar Pattern
- Six symbol characters from number set C
- A normal Guard Bar Pattern
- A right Quiet Zone

The rightmost symbol character shall encode the Check Digit calculated in accordance with Section 7.10. A UPC-A Bar Code Symbol may be decoded as a 13-digit number by adding an implied leading zero to the GTIN-12. Figure 5.2.2.3.3 -1 is an example of a UPC-A Bar Code Symbol.

**Figure 5.2.2.3.3 - 1 UPC-A Bar Code Symbol**

### 5.2.2.3.4. UPC-E Bar Code Symbols

The UPC-E Bar Code Symbol shall be made up as follows, reading from left to right:

- A left Quiet Zone
- A normal Guard Bar Pattern
- Six symbol characters from number sets A and B
- A special Guard Bar Pattern
- A right Quiet Zone

The UPC-E Bar Code Symbol may only be used to encode GTIN-12 Element Strings that commence with a zero and contain a sequence of four or five zeroes in defined positions, as shown in Figure 5.2.2.3.4 - 1. These zeros are removed from the data during encoding by the zero-suppression process described in Section 5.2.2.3.4.1. Figure 5.2.2.3.4 - 1 is an example of a UPC-E Bar Code Symbol.

**Figure 5.2.2.3.4 - 1 UPC-E Bar Code Symbol (Encoding 00123400057 by Zero-Suppression)**



**5.2.2.3.4.1. Encodation of the UPC-E Bar Code Symbol**

The following algorithm describes the encodation of a data string suitable for zero-suppression:

1. Let D1, D2, and D3 through D12 denote the GTIN-12 data characters (including Check Digit). D1 shall always be zero. D12 shall be the Check Digit calculated according to the algorithm in Section 7.10. Let X1 and X2 through X6 denote the six symbol characters in the final UPC-E Bar Code Symbol..
2. Convert D2 through D11 into a symbol character string by removing zeroes according to the following rules:

If	Then
<ul style="list-style-type: none"> <li>▪ D11 equals 5, 6, 7, 8, or 9</li> <li>▪ and D7 to D10 inclusive are all 0</li> <li>▪ and D6 is not 0</li> </ul>	<ul style="list-style-type: none"> <li>▪ D7 to D10 are not encoded.</li> <li>▪ Symbol character:   X1   X2   X3   X4   X5   X6</li> <li>▪ Data character:     D2   D3   D4   D5   D6   D11</li> </ul>

If	Then
<ul style="list-style-type: none"> <li>▪ D6 to D10 inclusive are all 0</li> <li>▪ and D5 is not 0</li> </ul>	<ul style="list-style-type: none"> <li>▪ D6 to D10 are not encoded and X6 = 4.</li> <li>▪ Symbol character:   X1   X2   X3   X4   X5   X6</li> <li>▪ Data character:     D2   D3   D4   D5   D11   4</li> </ul>

If	Then
<ul style="list-style-type: none"> <li>▪ D4 is 0, 1, or 2</li> <li>▪ and D5 to D8 inclusive are all 0</li> </ul>	<ul style="list-style-type: none"> <li>▪ D5 to D8 are not encoded.</li> <li>▪ Symbol character:   X1   X2   X3   X4   X5   X6</li> <li>▪ Data character:     D2   D3   D9   D10   D11   D4</li> </ul>

If	Then
<ul style="list-style-type: none"> <li>▪ D4 is 3, 4, 5, 6, 7, 8, or 9</li> <li>▪ and D5 to D9 inclusive are all 0</li> </ul>	<ul style="list-style-type: none"> <li>▪ D5 to D9 are not encoded and X6 = 3.</li> <li>▪ Symbol character:   X1   X2   X3   X4   X5   X6</li> <li>▪ Data character:     D2   D3   D4   D10   D11   3</li> </ul>

3. Determine the number sets for the implicit encodation of D12 from Figure 5.2.2.3.4.1 - 1
4. Encode symbol characters X1 to X6 using number sets A and B as determined in Step 3

**Figure 5.2.2.3.4.1 - 1**

Value of Check Digit D12	Number Sets Used for Numbering a UPC-E Bar Code Symbol					
	Symbol Character Position					
	1	2	3	4	5	6
0	B	B	B	A	A	A
1	B	B	A	B	A	A
2	B	B	A	A	B	A
3	B	B	A	A	A	B
4	B	A	B	B	A	A
5	B	A	A	B	B	A
6	B	A	A	A	B	B
7	B	A	B	A	B	A
8	B	A	B	A	A	B
9	B	A	A	B	A	B

**Figure 5.2.2.3.4.1 - 2**

Example 1	Original Data	Zero-Suppressed	Rule
	0 1 2 3 4 5 0 0 0 0 5 8	1 2 3 4 5 5	2a
		B A B A A B	

**Figure 5.2.2.3.4.1 - 3**

Example 2	Original Data	Zero-Suppressed	Rule
	0 4 5 6 7 0 0 0 0 0 8 0	4 5 6 7 8 4	2b
		B B B A A A	

**Figure 5.2.2.3.4.1 - 4**

Example 3	Original Data	Zero-Suppressed	Rule
	0 3 4 0 0 0 0 0 5 6 7 3	3 4 5 6 7 0	2c
		B B A A A B	

**Figure 5.2.2.3.4.1 - 5**

Example 4	Original Data	Zero-Suppressed	Rule
	0 9 8 4 0 0 0 0 0 7 5 1	9 8 4 7 5 3	2d
		B B A B A A	



**Note:** The number sets used to implicitly encode the Check Digit are shown in the zero-suppressed column.

### 5.2.2.3.4.2. Decoding a UPC-E Bar Code Symbol

Derivation of the 12-digit data string from the characters encoded in the UPC-E Bar Code Symbol can be performed according to Figure 5.2.2.3.4.2 - 1.

Figure 5.2.2.3.4.2 - 1 Decoding a UPC-E Bar Code Symbol

Encoded UPC-E Bar Code Symbol Digits								Decoded Number											
	P1	P2	P3	P4	P5	P6		D1	D2	D3	D4	D5	D6	D7	D8	D9	D10	D11	D12
(0)	X1	X2	X3	X4	X5	0	(C)	(0)	X1	X2	0	<u>0</u>	<u>0</u>	<u>0</u>	<u>0</u>	X3	X4	X5	(C)
(0)	X1	X2	X3	X4	X5	1	(C)	(0)	X1	X2	1	<u>0</u>	<u>0</u>	<u>0</u>	<u>0</u>	X3	X4	X5	(C)
(0)	X1	X2	X3	X4	X5	2	(C)	(0)	X1	X2	2	<u>0</u>	<u>0</u>	<u>0</u>	<u>0</u>	X3	X4	X5	(C)
(0)	X1	X2	X3	X4	X5	3	(C)	(0)	X1	X2	X3	<u>0</u>	<u>0</u>	<u>0</u>	<u>0</u>	<u>0</u>	X4	X5	(C)
(0)	X1	X2	X3	X4	X5	4	(C)	(0)	X1	X2	X3	X4	<u>0</u>	<u>0</u>	<u>0</u>	<u>0</u>	<u>0</u>	X5	(C)
(0)	X1	X2	X3	X4	X5	5	(C)	(0)	X1	X2	X3	X4	X5	<u>0</u>	<u>0</u>	<u>0</u>	<u>0</u>	5	(C)
(0)	X1	X2	X3	X4	X5	6	(C)	(0)	X1	X2	X3	X4	X5	<u>0</u>	<u>0</u>	<u>0</u>	<u>0</u>	6	(C)
(0)	X1	X2	X3	X4	X5	7	(C)	(0)	X1	X2	X3	X4	X5	<u>0</u>	<u>0</u>	<u>0</u>	<u>0</u>	7	(C)
(0)	X1	X2	X3	X4	X5	8	(C)	(0)	X1	X2	X3	X4	X5	<u>0</u>	<u>0</u>	<u>0</u>	<u>0</u>	8	(C)
(0)	X1	X2	X3	X4	X5	9	(C)	(0)	X1	X2	X3	X4	X5	<u>0</u>	<u>0</u>	<u>0</u>	<u>0</u>	9	(C)

**Notes:**

- The symbol characters at positions P1 and P2 through P5 of the UPC-E Bar Code Symbol are represented by X1 and X2 through X5.
- Re-inserted zeroes are indicated by underlining.
- The leading digit for UPC-E Bar Code Symbols, which is not encoded, is indicated by "0".
- The Check Digit implicitly encoded in UPC-E Bar Code Symbols is indicated by "C".

### 5.2.2.3.5. Add-On Symbols

The Add-On Symbols were designed to encode information supplementary to that in the main bar code symbol on periodicals, hardback, and paperback books. Because they provide reduced security, use of Add-On Symbols shall be limited to applications where rules in the application specification governing data format and content provide appropriate safeguards.

#### 5.2.2.3.5.1. Two-Digit Add-On Symbol

A two-digit Add-On Symbol may be used in specific applications to accompany an EAN-13, UPC-A, or UPC-E Bar Code Symbol. The two-digit Add-On Symbol is positioned following the right Quiet Zone of the main symbol and consists of the following:

- Add-On Guard Bar Pattern
- First digit of the additional number from number sets A or B
- Add-On delineator
- Second digit of the additional number from number sets A or B
- A right Quiet Zone

The Add-On Symbol has no right Guard Bar Pattern. It does not have an explicit Check Digit. Checking is done through the mix of the number sets (A or B) used for the two digits. The choice of number sets is linked to the value of the additional number as shown by Figure 5.2.2.3.5.1 - 1.

**Figure 5.2.2.3.5.1 - 1 Number Sets for Two-Digit Add-On Symbols**

Value of the digits carried by the Add-On Symbol	Left-Hand Digit	Right-Hand Digit
Multiple of 4 (00,04,08,..96)	A	A
Multiple of 4+1 (01,05,..97)	A	B
Multiple of 4+2 (02,06,..98)	B	A
Multiple of 4+3 (03,07,..99)	B	B

Figure 5.2.2.3.5.1 - 2 is an example of an EAN-13 Bar Code Symbol with a two-digit Add-On Symbol.

**Figure 5.2.2.3.5.1 - 2 EAN-13 Bar Code Symbol with Two-Digit Add-On Symbol**



### 5.2.2.3.5.2. Five-Digit Add-On Symbol

A five-digit Add-On Symbol may be used in specific applications to accompany an EAN-13, UPC-A, or UPC-E Bar Code Symbol. The five-digit Add-On Symbol is positioned following the right Quiet Zone of the main symbol and consists of the following:

- Add-On Guard Bar Pattern
- First digit of the Add-On number from number sets A or B
- Add-On delineator
- Second digit of the Add-On number from number sets A or B
- Add-On delineator
- Third digit of the Add-On number from number sets A or B
- Add-On delineator
- Fourth digit of the Add-On number from number sets A or B
- Add-On delineator
- Fifth digit of the Add-On number from number sets A or B
- A right Quiet Zone

The Add-On Symbol has no right Guard Bar Pattern. It does not have an explicit Check Digit. Checking is done through the mix of the number sets (A or B) used for the five digits. A value V is determined by the following procedure:

1. Sum the digits in Positions one, three, and five
2. Multiply the result of step 1 by 3
3. Sum the remaining digits (Positions two and four)

4. Multiply the result of step 3 by 9
5. Sum the results of steps 2 and 4
6. The value of V is the unit's position (lowest-order digit) of the result of step

**Example:**

To calculate the value of V for an Add-On Symbol carrying the number 86104, follow these steps:

1.  $8 + 1 + 4 = 13$
2.  $13 \times 3 = 39$
3.  $6 + 0 = 6$
4.  $6 \times 9 = 54$
5.  $39 + 54 = 93$
6.  $V = 3$

The number sets can then be determined by using Figure 5.2.2.3.5.2 - 1.

**Figure 5.2.2.3.5.2 - 1 Number Sets for Five-Digit Add-On Symbol**

Value of V	Number Sets Used for Symbol Characters				
	1	2	3	4	5
0	B	B	A	A	A
1	B	A	B	A	A
2	B	A	A	B	A
3	B	A	A	A	B
4	A	B	B	A	A
5	A	A	B	B	A
6	A	A	A	B	B
7	A	B	A	B	A
8	A	B	A	A	B
9	A	A	B	A	B

Since  $V = 3$  in Figure 5.2.2.3.5.2 - 1, the sequence of number sets used to encode the value 86104 is B A A A B.

Figure 5.2.2.3.5.2 - 2 shows an example of an EAN-13 Bar Code Symbol with a five-digit Add-On Symbol.

**Figure 5.2.2.3.5.2 – 2 EAN-13 Bar Code Symbol with Five-Digit Add-On Symbol**



## 5.2.2.4. Dimensions and Tolerances

### 5.2.2.4.1. Nominal Dimensions of Characters

Bar code symbols can be printed at various densities to accommodate a variety of printing and scanning processes. The significant dimensional parameter is **X**, the ideal width of a single module element. The X-dimension must be constant throughout a given symbol.

The dimensions of EAN-13, UPC-A, EAN-8 and UPC-E Bar Code Symbols may be referenced to a defined set of dimensions referred to as the nominal size symbol. Refer to Section 5.2.4.6 for dimensioned drawings of nominal size symbols.


The X-dimension at nominal size is 0.33 millimetre (0.013 inch).

The width of each bar (dark bar) and space (light bar) is determined by multiplying the X-dimension by the module width of each bar (dark bar) and space (light bar) (1, 2, 3, or 4). There is an exception for characters 1, 2, 7, and 8. For these characters, the bars (dark bars) and spaces (light bars) are reduced or enlarged by one-thirteenth of a module to provide a uniform distribution of bar width tolerances and thus improve scanning reliability.

The reduction or enlargement in millimetres at nominal size of the bars (dark bars) and spaces (light bars) for the characters 1, 2, 7, and 8 in the number sets A, B, and C is shown in Figure 5.2.2.4.1 - 1.

**Figure 5.2.2.4.1 - 1 Reduction/Enlargement for Characters 1, 2, 7, and 8**

Character Value	Number Set A		Number Sets B and C	
	Bar (Dark Bar) mm	Space (Light Bar) mm	Bar (Dark Bar) mm	Space (Light Bar) mm
1	- 0.025	+0.025	+0.025	- 0.025
2	- 0.025	+0.025	+0.025	- 0.025
7	+0.025	- 0.025	- 0.025	+0.025
8	+0.025	- 0.025	- 0.025	+0.025

 **Note:** The existing symbol generation equipment that uses a value of 0.030 millimetre for the reduction/enlargement factor at nominal size will continue to be used for the foreseeable future.

### 5.2.2.4.2. Symbol Height

For EAN-13, UPC-A, and UPC-E Bar Code Symbols the approximate height of the symbol, including the human readable information, at the nominal size is 25.9 millimetres (1.0 inch).

For EAN-8 Bar Code Symbols the approximate height of the symbol, including the human readable information, at the nominal size is 21.3 millimetres (0.8 inch).

The height of any two-digit or five-digit Add-On Symbol used, including the human readable information, must not extend outside the symbol height dimensions of the primary symbol.

In EAN-13, EAN-8, UPC-A, and UPC-E Bar Code Symbols, the bars (dark bars) forming the left, centre, and right Guard Bar Patterns shall be extended downward by 5x (e.g., 1.65 millimetres (0.065 inch)). This shall also apply to the bars (dark bars) of the first and last symbol characters of the UPC-A Bar Code Symbol.

Symbol height is not modular.

### 5.2.2.4.3. X-Dimension (Magnification Factor)

In the past the term "magnification factor" was extensively used to specify the size of a bar code symbol. This technique relied upon setting a nominal size (100 percent) that was directly related to a given X-dimension. Since January 2000, the more precise term "X-dimension" has been used to specify permissible symbol sizes (see Section 5.5).

The X-dimension of an Add-On Symbol shall be the same as the X-dimension of its associated main symbol.

### 5.2.2.4.4. Quiet Zone

The minimum Quiet Zone width required by the main bar code symbol is 7x. However, other minimum Quiet Zone dimensions are specified for some symbol types due to the size and location of their Human Readable Interpretation. These dimensions are noted in Figure 5.2.2.4.4 - 1.

Figure 5.2.2.4.4 - 1 Quiet Zone Widths by Version

Symbol Version	Left Quiet Zone		Right Quiet Zone	
	Modules	mm*	Modules	mm
EAN-13	11	3.63	7	2.31
EAN-8	7	2.31	7	2.31
UPC-A	9	2.97	9	2.97
UPC-E	9	2.97	7	2.31
Add-Ons (EAN)	7-12	2.31-3.96	5	1.65
Add-Ons (U.P.C.)	9-12	2.97-3.96	5	1.65

\* This is an example using an X-dimension of 0.33 millimetres.

**Note:** A useful device to help maintain the Quiet Zone in some production processes is to include a less than (<) and/or greater than (>) character in the Human Readable Interpretation field, with its apex aligned with the edge of the Quiet Zone. If this device is used, the character(s) shall be positioned in accordance with the appropriate drawings in Section 5.2.4.6.

### 5.2.2.4.5. Symbol Length

The symbol length in modules, including the minimum Quiet Zones, shall be as indicated in Figure 5.2.2.4.5 - 1.

Figure 5.2.2.4.5 - 1 Symbol Length in Modules

Symbol Type	Length
EAN-13	113
UPC-A	113
EAN-8	81
UPC-E	67
Two-digit Add-On	25
Five-digit Add-On	52
EAN-13 or UPC-A and two-digit Add-On	138
UPC-E and two-digit Add-On	92
EAN-13 or UPC-A and five-digit Add-On	165
UPC-E and five-digit Add-On	119

### 5.2.2.4.6. Positioning of the Add-On Symbol

The Add-On Symbol shall not encroach on the right Quiet Zone of the main symbol. The maximum separation shall be 12x.

The bottom edge of the bars (dark bars) in the Add-On Symbol shall be horizontally aligned with the bottom edge of the guard bars of the main symbol.

### 5.2.3. Reference Decode Algorithm

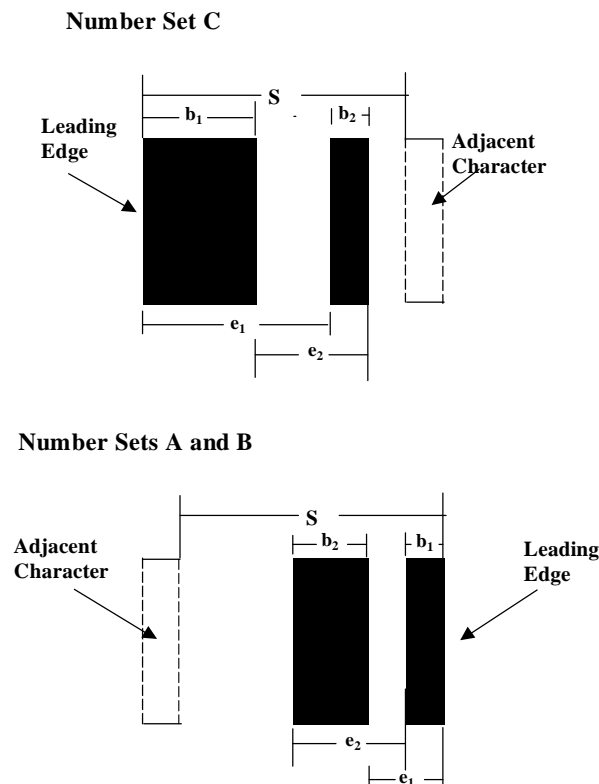
Decode algorithms are used by scanning equipment to convert the bar and space patterns of the bar code into data characters. As a matter of policy, GS1 makes no attempt to specify or standardise equipment beyond stating that it should be capable of reading symbols produced in accordance with the specifications laid out in this manual.

Bar code reader systems are designed to read imperfect symbols to the extent that practical algorithms permit. This section describes the reference decode algorithm used to determine decode and decodability in symbol verification in accordance with *ISO 15416*.

For each symbol character, let S equal the total measured width of the character. The value S is used to determine reference threshold (RT) values. Individual edge to similar edge measurements (e) are then compared to the reference threshold to determine E values. Character values are determined from E values.

Value e1 is defined as the measurement from the leading edge of a bar (dark bar) to the leading edge of the adjacent bar (dark bar). Value e2 is defined as the measurement from the trailing edge of a bar (dark bar) to the trailing edge of the adjacent bar (dark bar). For number sets A and B, the right edge of each of the two bars (dark bars) is considered to be leading, while for number set C, the left edge of each bar (dark bar) is considered to be leading. These relationships are illustrated in Figure 5.2.3 - 1.

Figure 5.2.3 - 1 Symbol Character Decode Measurements



Reference thresholds RT1, RT2, RT3, RT4, and RT5 are given by:

- $RT1 = (1.5/7)S$
- $RT2 = (2.5/7)S$
- $RT3 = (3.5/7)S$
- $RT4 = (4.5/7)S$
- $RT5 = (5.5/7)S$

Within each character, the measurements  $e_1$  and  $e_2$  are compared with the reference thresholds. The corresponding integer values  $E_1$  and  $E_2$  are considered to be equal to 2, 3, 4, or 5 as follows:

- If  $RT1 \leq e_i < RT2$ ,  $E_i = 2$
- If  $RT2 \leq e_i < RT3$ ,  $E_i = 3$
- If  $RT3 \leq e_i < RT4$ ,  $E_i = 4$
- If  $RT4 \leq e_i < RT5$ ,  $E_i = 5$

Otherwise the character is in error.

Figure 5.2.3 - 2, use the values of  $E_1$  and  $E_2$  as the primary determinant for the symbol character value.

**Figure 5.2.3 - 2 Bar Code Symbol Decoding**

Character	Number Set	Primary Determinant		Secondary Determinant $7(b_1 + b_2)/S$
		E1	E2	
0	A	2	3	
1	A	3	4	$\leq 4$
2	A	4	3	$\leq 4$
3	A	2	5	
4	A	5	4	
5	A	4	5	
6	A	5	2	
7	A	3	4	$>4$
8	A	4	3	$>4$
9	A	3	2	
0	B and C	5	3	
1	B and C	4	4	$>3$
2	B and C	3	3	$>3$
3	B and C	5	5	
4	B and C	2	4	
5	B and C	3	5	
6	B and C	2	2	
7	B and C	4	4	$\leq 3$
8	B and C	3	3	$\leq 3$
9	B and C	4	2	

✓ **Note:**  $b_1$  and  $b_2$  are the widths of the two bar (dark bar) elements

The character is uniquely determined for all combinations of  $E_1$  and  $E_2$  except for the following four cases:

- $E_1 = 3$  and  $E_2 = 4$  (characters 1 and 7 in number set A)
- $E_1 = 4$  and  $E_2 = 3$  (characters 2 and 8 in number set A)
- $E_1 = 4$  and  $E_2 = 4$  (characters 1 and 7 in number sets B and C)
- $E_1 = 3$  and  $E_2 = 3$  (characters 2 and 8 in number sets B and C)

These cases require that the combined width of the two bars (dark bars) be tested as follows:

- For  $E_1 = 3$  and  $E_2 = 4$ :
  - Character is 1 if  $7 \times (b_1 + b_2) / S \leq 4$
  - Character is 7 if  $7 \times (b_1 + b_2) / S > 4$
- For  $E_1 = 4$  and  $E_2 = 3$ :
  - Character is 2 if  $7 \times (b_1 + b_2) / S \leq 4$
  - Character is 8 if  $7 \times (b_1 + b_2) / S > 4$
- For  $E_1 = 4$  and  $E_2 = 4$ :
  - Character is 1 if  $7 \times (b_1 + b_2) / S > 3$
  - Character is 7 if  $7 \times (b_1 + b_2) / S \leq 3$
- For  $E_1 = 3$  and  $E_2 = 3$ :
  - Character is 2 if  $7 \times (b_1 + b_2) / S > 3$
  - Character is 8 if  $7 \times (b_1 + b_2) / S \leq 3$

The requirements on  $(b_1 + b_2)$  are shown in Figure 5.2.3 - 2.

The same procedures shall be used to decode the symbol characters in any Add-On Symbol.

Use Figure 5.2.3 - 3 to determine the appropriate  $S$  measurement for calculating the reference threshold values  $RT_1$  and  $RT_2$  applicable to the auxiliary patterns of the main symbol. For each symbol or half symbol, the measurements of the appropriate auxiliary pattern  $e_i$  values are then compared to the reference thresholds to establish the integer  $E_i$  values. The determined values of  $E_1$ ,  $E_2$ ,  $E_3$ , and  $E_4$  shall match those of valid auxiliary patterns as shown in Figure 5.2.3 - 4. Otherwise the symbol is in error.

Figure 5.2.3 – 3 Auxiliary Pattern Measurements

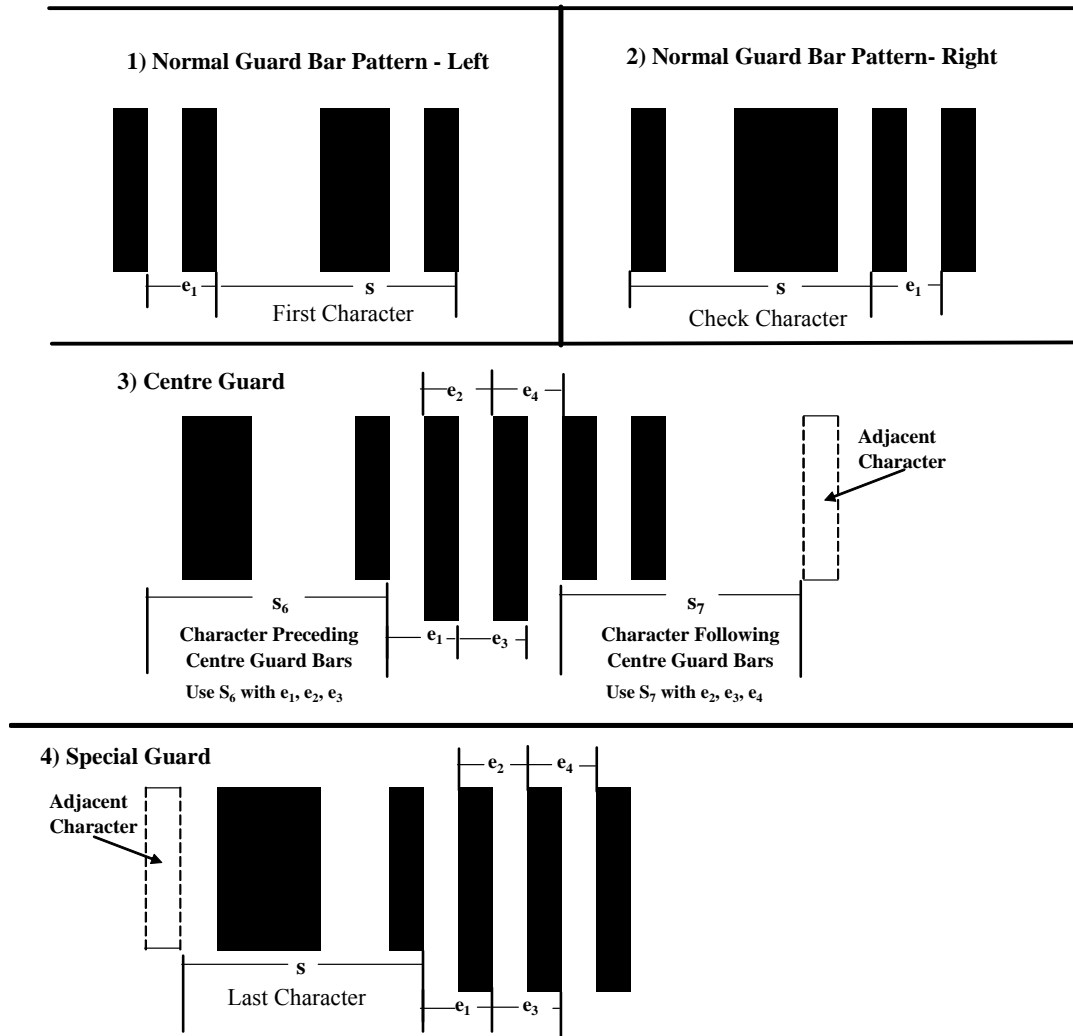


Figure 5.2.3- 4 Main Symbol Auxiliary Pattern E Values

Auxiliary Guard Patterns	E1	E2	E3	E4
Normal Guard Bar Pattern	2			
Centre Guard Bar Pattern (left half)	2	2	2	
Centre Guard Bar Pattern (right half)		2	2	2
Special Guard Bar Pattern	2	2	2	2

### 5.2.4. Human Readable Interpretation

The human readable digits shall be printed underneath the main symbol and above the Add-On Symbol. A clearly legible font shall be used for these digits, and OCR-B as defined in ISO 1073-2: Alphanumeric character sets for optical recognition; Part 2: Character set OCR-B; Shapes and dimensions of the printed image, is recommended. This font is referenced only as a convenient standard typeface, and it is not intended that these characters be machine read or verified.

Reasonable alternative type fonts and character sizes are acceptable provided the Human Readable Interpretation is clearly legible.

All the encoded digits for EAN-13, UPC-A, and EAN-8 Bar Code Symbols, and the Add-On Symbols shall be shown in Human Readable Interpretation form. For UPC-E Bar Code Symbols, the six digits directly encoded together with the leading zero and the implicitly encoded Check Digit shall be shown in Human Readable Interpretation form. Figures 5.2.2.3.1 - 2, 5.2.2.3.2 - 1, 5.2.2.3.3 - 1, 5.2.2.3.4 - 1, 5.2.2.3.5.1 - 2, and 5.2.2.3.5.2 - 2 illustrate each type of symbol and its Human Readable Interpretation.

The height of the digits in the nominal size symbol is 2.75 millimetres. The minimum space between the top of the digits and the bottom of the bars (dark bars) shall be 0.5X. Normally the minimum is one module, which is close enough to keep the Human Readable Interpretation associated with the symbol.

In the EAN-13, the leftmost digit, which is encoded by variable parity, is printed to the left of the start guard pattern in line with the other digits.

For UPC-A and UPC-E Bar Code Symbols, the size of the first and last digits should be reduced to a maximum width equivalent to four modules. The height is reduced proportionally. The right-hand side of the first digit is positioned five module widths to the left of the leftmost guard bar. The left-hand side of the last digit is positioned five module widths to the right of the rightmost guard bar for UPC-A Bar Code Symbols and three module widths for UPC-E Bar Code Symbols. The bottom edge of the first and last digit shall be aligned with the bottom edge of the remaining full size digits.

The Human Readable Interpretation of the Add-On Symbol shall be above the symbol. The digits shall be the same height as those of the main symbol. The upper edges of the digits are aligned with the upper edges of the bars (dark bars) of the main symbol. The minimum space between the bottom of the digits and the top of the bars (dark bars) shall be 0.5X.

Some industries use specific variations of the recommended Human Readable Interpretation, such as inserted hyphens to segment the number field. An example of this is shown in Section [5.2.4.6](#).


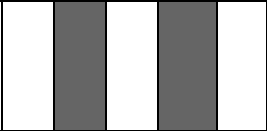

### 5.2.4.1. Character Values in the EAN/UPC Symbology Family

Figure 5.2.4.1 - 1

Value of Character	Number Set A (Odd)	Number Set B (Even)	Number Set C (Even)
0			
1			
2			
3			
4			
5			
6			
7			
8			
9			

### 5.2.4.2. Auxiliary Characters in the EAN/UPC Symbology Family

Figure 5.2.4.2 - 1

Auxiliary Character	
Normal Guard Bar Pattern (right and left)	
Centre Guard Bar Pattern	
UPC-E Right Guard Bar Pattern	

### 5.2.4.3. Logical Structure of an EAN-13 and UPC-A Bar Code Symbol Excluding Quiet Zones

Figure 5.2.4.3 - 1

Logical Structure of an EAN-13 or UPC-A Bar Code Symbol (Excluding Quiet Zones)				
Left Guard Bar Pattern	Characters 12 Through 7 (Left Half)	Centre Guard Bar Pattern	Characters 6 Through 1 (Right Half)	Right Guard Bar Pattern
3 modules	42 modules (6x7)	5 modules	42 modules (6x7)	3 modules
Total number of modules = 95				

Figure 5.2.4.3 - 2

Character Position												
Value of the Thirteenth Character	Number Set Used for Representing Characters 12 Through 7						Number Set Used for Representing Characters 6 Through 1					
	12	11	10	9	8	7	6	5	4	3	2	1
0	A	A	A	A	A	A	ALWAYS USE NUMBER SET C					
1	A	A	B	A	B	B						
2	A	A	B	B	A	B						
3	A	A	B	B	B	A						
4	A	B	A	A	B	B						
5	A	B	B	A	A	B						
6	A	B	B	B	A	A						
7	A	B	A	B	A	B						
8	A	B	A	B	B	A						
9	A	B	B	A	B	A						

### 5.2.4.4. Logical Structure of an EAN-8 Bar Code Symbol Excluding Quiet Zones

Figure 5.2.4.4 - 1

Logical Structure of an EAN-8 Bar Code Symbol (Excluding Quiet Zones)				
Left Guard Bar Pattern	Characters 8 Through 5 (Left Half)	Centre Guard Bar Pattern	Characters 4 Through 1 (Right Half)	Right Guard Bar Pattern
3 modules	28 modules (4x7)	5 modules	28 modules (4x7)	3 modules
Total number of modules = 67				

Figure 5.2.4.4 - 2

Character Position							
Number Set Used for Representing Characters 8 Through 5				Number Set Used for Representing Characters 4 Through 1			
8	7	6	5	4	3	2	1
ALWAYS USE NUMBER SET A				ALWAYS USE NUMBER SET C			

### 5.2.4.5. Logical Structure of a UPC-E Bar Code Symbol Excluding Quiet Zones

Figure 5.2.4.5 - 1

Logical Structure of a UPC-E Bar Code Symbol (Excluding Quiet Zones)		
Normal Guard Bar Pattern	Six Symbol Characters (Note the Use of Variable Parity)	Special Guard Bar Pattern (UPC-E)
3 modules	42 modules (6x7)	6 modules
Total number of modules = 51		

Figure 5.2.4.5 - 2

Value of Prefix Digit	Value of Check Digit	Number Sets Used for Numbering a UPC-E Bar Code Symbol					
		1	2	3	4	5	6
0	0	B	B	B	A	A	A
0	1	B	B	A	B	A	A
0	2	B	B	A	A	B	A
0	3	B	B	A	A	A	B
0	4	B	A	B	B	A	A
0	5	B	A	A	B	B	A
0	6	B	A	A	A	B	B
0	7	B	A	B	A	B	A
0	8	B	A	B	A	A	B
0	9	B	A	A	B	A	B

### 5.2.4.6. Symbol Formats at Nominal Dimensions (Not to Scale)

Figure 5.2.4.6 - 1 EAN-13 Bar Code Symbol



Figure 5.2.4.6 - 2 UPC-A Bar Code Symbol



Figure 5.2.4.6 - 3



Figure 5.2.4.6 - 4

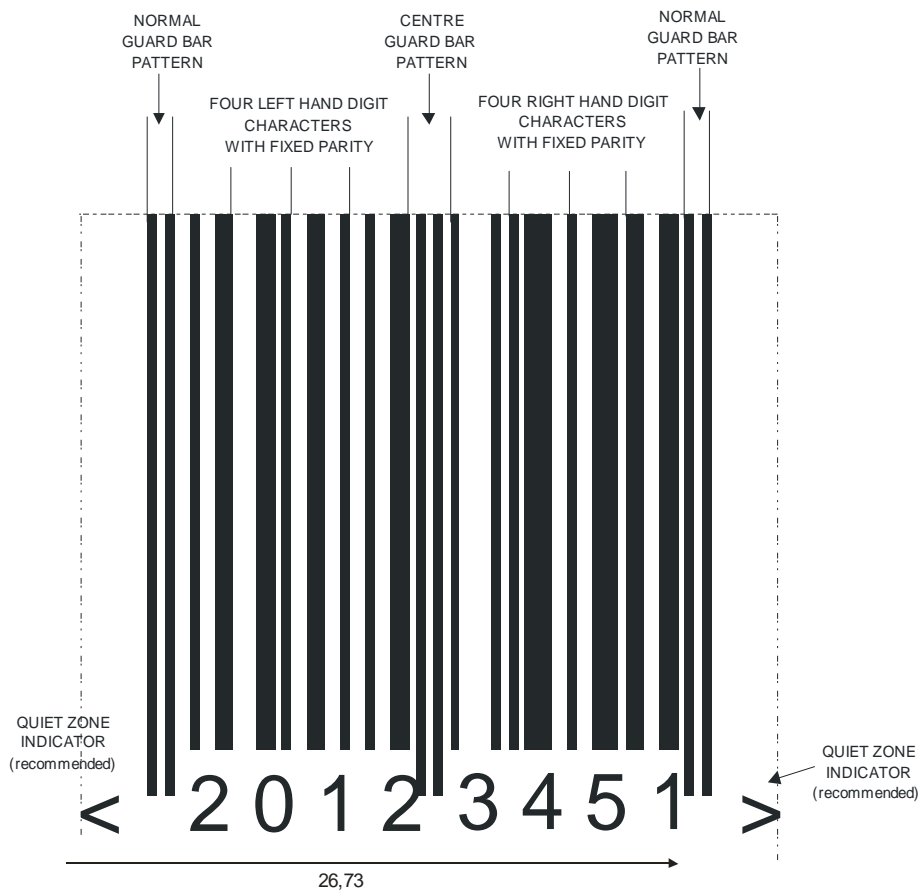


Figure 5.2.4.6 - 5 UPC-E Bar Code Symbol



Figure 5.2.4.6 - 6 UPC-A Bar Code Symbol with Two-Digit Add-On Symbol

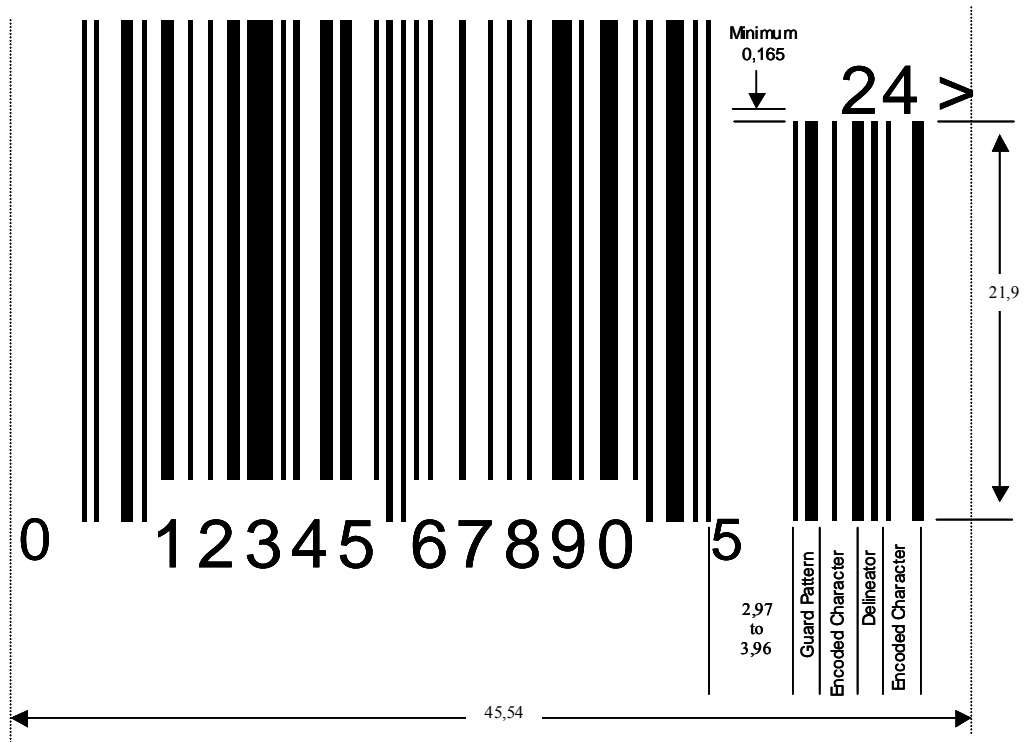
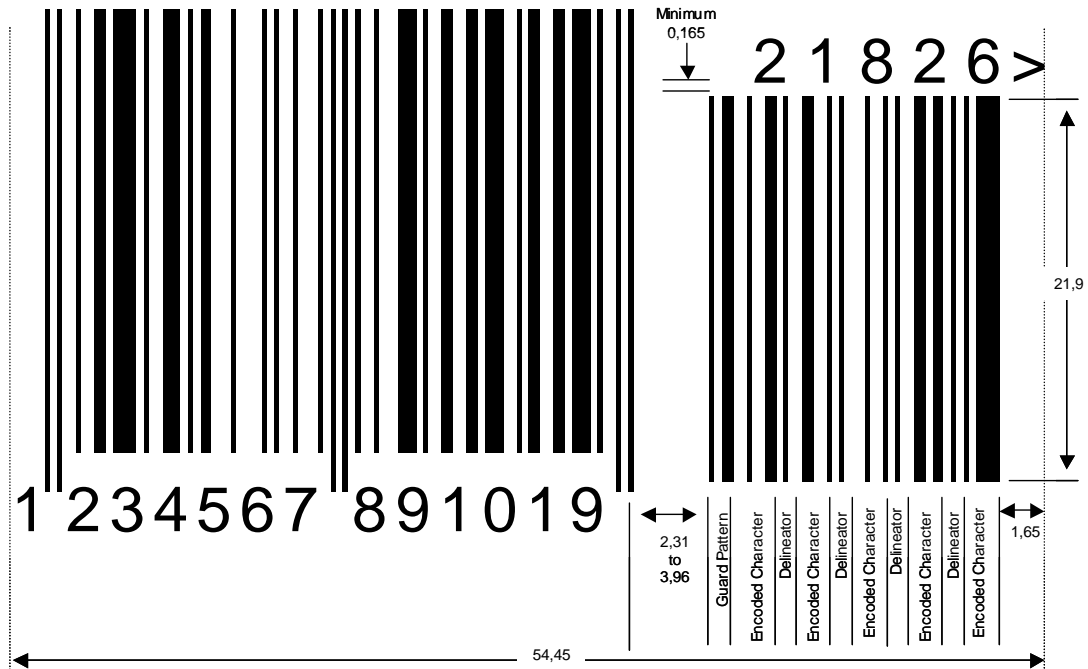


Figure 5.2.4.6 - 7 EAN-13 Bar Code Symbol with Five-Digit Add-On Symbol




5.2.4.7. Dimensions of Modules and Symbols at Different Levels of Magnification

Figure 5.2.4.7 - 1

Magnification Factor	Ideal Module Width [mm]	EAN-13/UPC-A Dimensions [mm]		EAN-8 Dimensions [mm]	
		Width	Height	Width	Height
0.80	0.264	29.83	20.73	21.38	17.05
0.85	0.281	31.70	22.02	22.72	18.11
0.90	0.297	33.56	23.32	24.06	19.18
0.95	0.313	35.43	24.61	25.39	20.24
1.00	0.330	37.29	25.91	26.73	21.31
1.05	0.346	39.15	27.21	28.07	22.38
1.10	0.363	41.02	28.50	29.40	23.44
1.15	0.379	42.88	29.80	30.74	24.51
1.20	0.396	44.75	31.09	32.08	25.57
1.25	0.412	46.61	32.39	33.41	26.64
1.30	0.429	48.48	33.68	34.75	27.70
1.35	0.445	50.34	34.98	36.09	28.77
1.40	0.462	52.21	36.27	37.42	29.83
1.45	0.478	54.07	37.57	38.76	30.90

Magnification Factor	Ideal Module Width [mm]	EAN-13/UPC-A Dimensions [mm]		EAN-8 Dimensions [mm]	
		Width	Height	Width	Height
1.50	0.495	55.94	38.87	40.10	31.97
1.55	0.511	57.80	40.16	41.43	33.03
1.60	0.528	59.66	41.46	42.77	34.10
1.65	0.544	61.53	42.75	44.10	35.16
1.70	0.561	63.39	44.05	45.44	36.23
1.75	0.577	65.26	45.34	46.78	37.29
1.80	0.594	67.12	46.64	48.11	38.36
1.85	0.610	68.99	47.93	49.45	39.42
1.90	0.627	70.85	49.23	50.79	40.49
1.95	0.643	72.72	50.52	52.12	41.55
2.00	0.660	74.58	51.82	53.46	42.62

 **Note:** Refer to Section [5.5](#) for the minimum, nominal, and maximum X-dimensions, and symbol heights for bar code symbols.

### 5.3. Linear Bar Codes - ITF-14 Symbology Specifications

#### 5.3.1. Symbology Characteristics

In the GS1 System, the characteristics of ITF-14 Symbols are:

- Encodable character set: numeric 0 to 9 (ASCII characters 48 to 57 inclusive, in accordance with ISO/IEC 646)
- Code type: continuous
- Elements per symbol character: five (two wide and three narrow) encoded as either five bars (dark bars) or five spaces (light bars)
- Self-checking symbol character
- Data string length encodable: fixed length at 14 digits
- Bidirectionally decodable
- One Check Digit is required (see Section 7.10)
- The symbol character density for ITF-14 is 16 to 18 modules per symbol character pair, depending on the wide-to-narrow ratio. The value is 16, based on the target ratio of 2.5 to 1.
- The non-data overhead is eight to nine modules, depending on the wide-to-narrow ratio. The value is 8.5, based on the target ratio of 2.5 to 1.

### 5.3.1.1. Symbol Structure

An ITF-14 Symbol includes:

- A left Quiet Zone
- A start pattern
- Seven pairs of symbol characters representing data
- A stop pattern
- A right Quiet Zone

### 5.3.1.2. Character Encodation

#### 5.3.1.2.1. Data Character Encodation

Figure 5.3.1.2.1 - 1 defines the ITF-14 Symbol's character encodation. In the binary representation column, the character 1 represents a wide element and 0 represents a narrow element.

**Figure 5.3.1.2.1 - 1 Binary Representation of Character Encodation**

Data Character	Binary Representation				
0	0	0	1	1	0
1	1	0	0	0	1
2	0	1	0	0	1
3	1	1	0	0	0
4	0	0	1	0	1
5	1	0	1	0	0
6	0	1	1	0	0
7	0	0	0	1	1
8	1	0	0	1	0
9	0	1	0	1	0

Figure 5.3.1.2.1 - 1 uses a modified binary coded decimal encoding scheme. The four leftmost bit positions for each character are assigned weights of 1, 2, 4, and 7, from left to right; the fifth position is used for an even parity bit. The sum of the positional weights of the 1 bits is equivalent to the data character value, except in the case of data character 0, where the weights 4 and 7 are applied. The parity bit ensures that there are always two 1 bits per character.

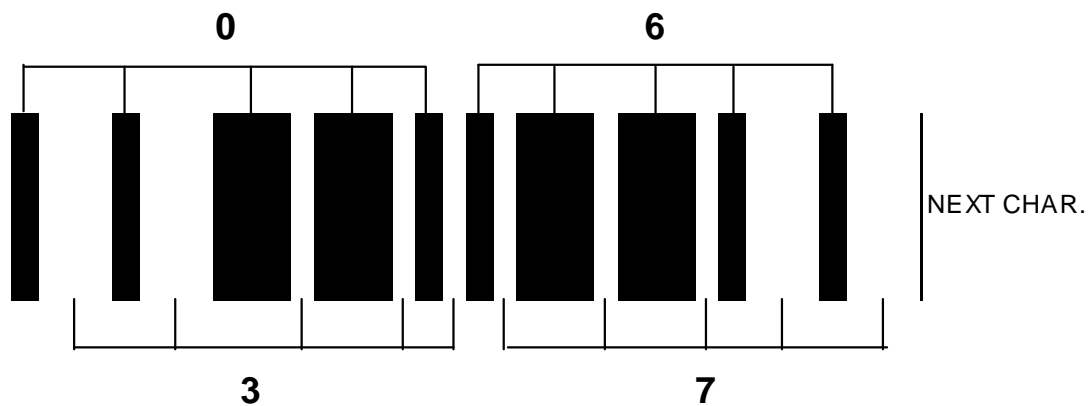
The algorithm shown in Figure 5.3.1.2.1 - 2 defines the rules for converting numeric data into the symbol characters of an ITF-14 Symbol (numeric data equals the Global Trade Item Number (GTIN) and, therefore, already contains the Check Digit).

Figure 5.3.1.2.1 - 2

Step in Algorithm	Example
1. Calculate Check Digit for 0367123456789	367
2. With ITF-14 Symbols, the data string, including the Check Digit, will always be a 14-digit number. The leftmost four digits of this number are 0367.	0367
3. Subdivide the numeric string into digit pairs. The leftmost four digits of the number are 0367.	0367 03 and 67
4. Encode the digit pairs as follows: <ul style="list-style-type: none"> <li>Encode the leading digit of each pair into bar patterns, as shown in Figure 5.3.1.2.1 - 1</li> <li>Encode the second digit of each pair into space patterns, as shown in Figure 5.3.1.2.1 - 1</li> </ul>	0 and 6 3 and 7
5. Form each symbol character pair by taking the bar (dark bar) and space (light bar) elements alternately from the patterns derived from the two steps in 4, commencing with the first bar (dark bar) of the pattern for the first digit, followed by the first space (light bar) of the pattern for the second digit.	

Figure 5.3.1.2.1 - 3 illustrates the sequence of bar (dark bar) and space (light bar) elements corresponding to the data character pairs 03 and 67.

Figure 5.3.1.2.1 - 3 ITF-14 Symbol Character Pairs Encoding 03 and 67



### 5.3.1.2.2. Start and Stop Patterns

The start pattern shall consist of four narrow elements in the sequence “bar (dark bar) - space (light bar) - bar (dark bar) - space (light bar).” The stop pattern shall consist of a “wide bar (dark bar) - narrow space (light bar) - narrow bar (dark bar)” sequence.

The start pattern shall be positioned at the normal left end of the symbol characters adjacent to the first bar (dark bar) of the most significant digit. The stop pattern shall be positioned at the normal right end of the symbol characters adjacent to the final space (light bar) of the least significant digit.

There is no assigned Human Readable Interpretation of the start and stop patterns, and they shall not be transmitted by the decoder.

Figure 5.3.1.2.2 - 1 illustrates the start and stop patterns and their relationship to the symbol characters.

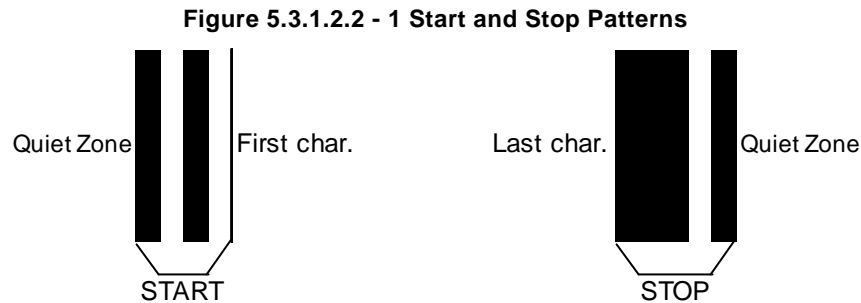
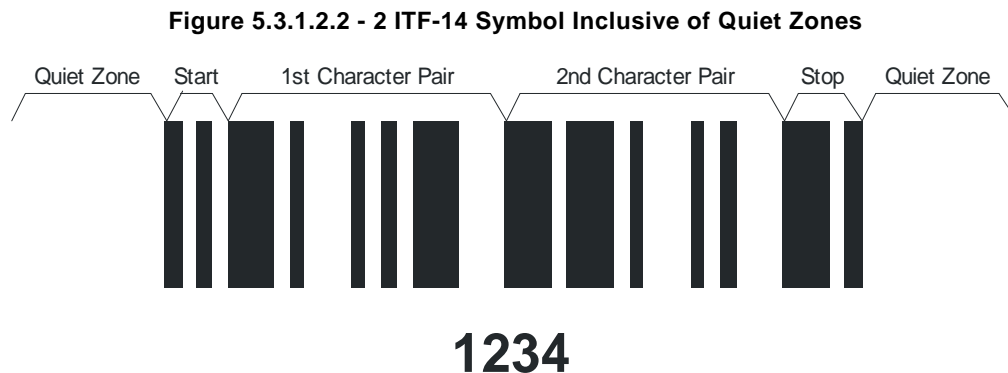


Figure 5.3.1.2.2 - 2 illustrates a complete bar code for the number 1234, showing the necessary Quiet Zones.



### 5.3.1.2.3. Check Digit

A Check Digit is required in the ITF-14 Symbology. Section 7.10 defines the Check Digit position and calculation.

### 5.3.1.3. Dimensions and Tolerances

ITF-14 Symbols shall use the following target dimensions:

The X-dimension of ITF-14 Symbols is defined by the application specification based on the needs of the application. Refer to Section 5.5.2.6 for specifications by application area.

In the ITF-14 Symbol target size, the theoretical widths of the bars (light or dark) are:

Narrow bar = 1.016 mm (0.04 in.)

Wide bar = 2.540 mm (0.10 in.). The target width of the wide bars (dark bars) is 2.5 times the width of the narrow bars (dark bars).

The target width of an ITF-14 Symbol ten element character pair is 16.256 millimetres (0.64 inch), and the corresponding widths of auxiliary characters are:


Start Character = 4.064 mm (0.16 in.)

Stop Character = 4.572 mm (0.18 in.)

The Quiet Zones to the right and left of the symbol are compulsory. The minimum width of the Quiet Zone is 10X. Both Quiet Zones in an ITF-14 Symbol have target widths of 10.2 millimetres (0.40 inch).

A minimum space of 1 millimetre (0.04 inch) between the bottom line of the Bearer Bar and the top of the human readable characters is required.

For ITF-14 Symbols, the height of the bars (dark bars) in the target size symbol is 32 millimetres (1.25 inches).

-  **Note:** All dimensions given are ideal, theoretical values corresponding to the target size of symbols as used in the General Distribution Scanning environment. These dimensions are not intended to be used directly in the preparation of bar code symbols

The length of an ITF-14 Symbol, including Quiet Zones, can be calculated from the following expression:

$$W = (P(4N+6)+N+6)X+2Q$$

Where:

- **W** is the length in millimetres
- **P** is the number of character pairs
- **N** is the wide-to-narrow ratio
- **X** is the width of a narrow element in millimetres
- **Q** is the width of the Quiet Zone in millimetres

An ITF-14 Symbol has seven character pairs, a target wide-to-narrow ratio of 2.5:1, a target X width of 1.016 millimetres (0.04 inch), and Quiet Zone widths of 10.2 millimetres (0.40 inch). This corresponds to a total symbol width of 142.748 millimetres (5.8 inches)

#### 5.3.1.4. Reference Decode Algorithm

Bar code reading systems are designed to read imperfect symbols to the extent that practical algorithms permit. This section describes the reference decode algorithm used in the computation of the decodability value described in *ISO/IEC 15416*.

Decodability shall be determined as follows:

- Within each ITF-14 Symbol character (representing two digits), sort the bars ( $b_i$ ) and spaces ( $s_i$ ) such that:

$$b_1 < b_2 < b_3 < b_4 < b_5$$

$$s_1 < s_2 < s_3 < s_4 < s_5$$

- The determined X-dimension ( $Z$ ) is given by:

$$Z = b_1 + b_2 + b_3 + s_1 + s_2 + s_3 / 6$$

- Separation value ( $V_1$ ) is:

$$V_1 = (d/Z) - 0.5$$

where  $d$  = the smaller of  $(b_4 - b_3)$  or  $(s_4 - s_3)$

- Uniformity value ( $V_2$ ) is:

$$V_2 = 1 - u/Z$$

where  $u$  = the largest of:

$$b_5 - b_4$$

$$b_3 - b_1$$

$$s_5 - s_4$$

$$s_3 - s_1$$

- Narrowest element value ( $V_3$ ) is:  

$$V_3 = [(n/Z) - 0.25] / 0.75$$
 where  $n$  = the smaller of  $s_1$  or  $b_1$
- For each symbol character, determine the decodability value  $V$ .  $V$  is the smallest of  $V_1$ ,  $V_2$ , or  $V_3$ .
- The scan profile decodability value is the smallest value of  $V$  measured in a Scan Reflectance Profile (SRP). The reference decode algorithm fails when  $V$  exhibits a negative value.
- The decodability grade for each profile is determined from the decodability value according to ANSI X3.182, Table 3.

### 5.3.1.5. Bearer Bars

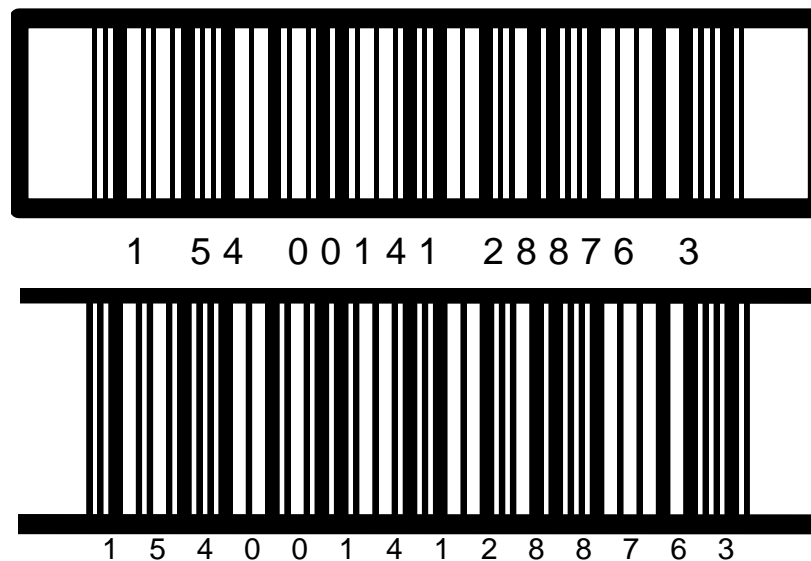
The purpose of a Bearer Bar is to equalise the pressure exerted by the printing plate over the entire surface of the symbol and to enhance reading reliability by helping to reduce the probability of misreads or short scans that may occur when a skewed scanning beam enters or exits the bar code symbol through its top or bottom edge.

The Bearer Bar is mandatory unless it is not technically feasible to apply it (in which case reading reliability will be reduced).

For printing methods requiring printing plates, the nominal Bearer Bar has a constant thickness of 4.8 millimetres (0.19 inch) and must completely surround the symbol, including its Quiet Zones, and butt directly against the top and bottom of the bars (dark bars) of the symbol.

For printing methods that do not require printing plates, the Bearer Bar should be a minimum of twice the width of a narrow bar (dark bar) and need only appear at the top and bottom of the symbol, butting directly against the top and bottom of the symbol bars (dark bars). The Bearer Bar may extend above and below the Quiet Zones. However, it is not mandatory to print the vertical sections of the Bearer Bar. See Figure 5.3.1.5 - 1.

Figure 5.3.1.5 - 1



### 5.3.1.6. Human Readable Interpretation

A clearly legible Human Readable Interpretation of the data characters (proportional to the size of the symbol) including a Check Digit should normally be printed with the symbol encoding the data characters. Start and stop patterns do not have Human Readable Interpretation. Character size and font are not specified, and the Human Readable Interpretation may be printed anywhere in the area surrounding the symbol as long as the Quiet Zones are not encroached upon.

### 5.3.1.7. Additional Features (Informative)

#### 5.3.1.7.1. Protection Against Short Scans

In ITF-14 Symbols, the bar (dark bar) patterns of the start and stop patterns may be found at the respective end and beginning of certain encoded symbol characters within the code. There is, therefore, no guarantee that a partial scan of the symbol will not produce a valid read for an embedded symbol having fewer characters.

In the GS1 System, short scans are very unlikely to happen, as the symbol must always contain 14 digits. However, a symbol containing more than 14 digits may cause a short scan of 14 digits. In this instance, the Check Digit offers security to detect this error.

These are the measures that should be taken to minimise the risk of partial read.

#### 5.3.1.7.2. Fixed Length Symbols

In any application standard, the number of characters encoded in an ITF-14 Symbol should be fixed for that application and reading or data processing equipment should be programmed to only accept messages of that defined length. An ITF-14 Symbol must always carry a 14-digit number.

### 5.3.1.8. Guidelines for the Use of ITF-14 (Informative)

#### 5.3.1.8.1. Autodiscrimination Compatibility

ITF-14 Symbols may be read by suitably programmed bar code readers that are designed to autodiscriminate the ITF Symbology from other symbologies. The ITF Symbology is fully distinguishable from and compatible with many symbologies including the ISO standard symbologies.

The decoder's valid set of symbologies should be limited to those needed by a given application to maximize reading security.

#### 5.3.1.8.2. System Considerations

It is important that the various components making up a bar code installation system (e.g., printers, labels, readers) operate in concert. A failure in any component, or a mismatch between components, can compromise the performance of the overall system.

### 5.3.1.9. Symbology Identifier (Informative)

The symbology identifier allocated to the ITF-14 Symbol in ISO/IEC 15424, which may be added as a preamble to the decoded data by a suitably programmed bar code reader, is: **]Im**

where:

- J** is ASCII character 93
- I** (upper case I) is the code character for the ITF-14 Symbology
- m** is a modifier character



**Note:** The symbology identifier **]I1** is the only symbology identifier used by GS1 with the ITF-14 Symbol. This information shall not be encoded in the bar code symbol, but should be generated by the decoder after decoding and transmitting as a preamble to the data message. The value of “m” in the symbology identifier is equal to 1, which indicates the Check Digit has been validated and transmitted by the scanner

### 5.3.1.10. Test Specifications (Informative)

To verify whether a symbol meets the specifications of the GS1 System, it shall be tested using the specification defined in *ISO/IEC 15416*, which details the conditions under which measurements should be made. The specification defines methods of determining an overall quality grade based on the attributes of the bar code symbol and determining its conformity with the system. For ITF-14 Symbols, the reference decode algorithm shall be the algorithm specified in Section 5.3.1.4.

Full details on bar code production and quality assessment can be found in Section 5.5.

The verifier shall determine the average wide-to-narrow ratio (N) for each profile. The value N should be computed character by character, then averaged over all characters in the symbol. The range indicated below is passing:

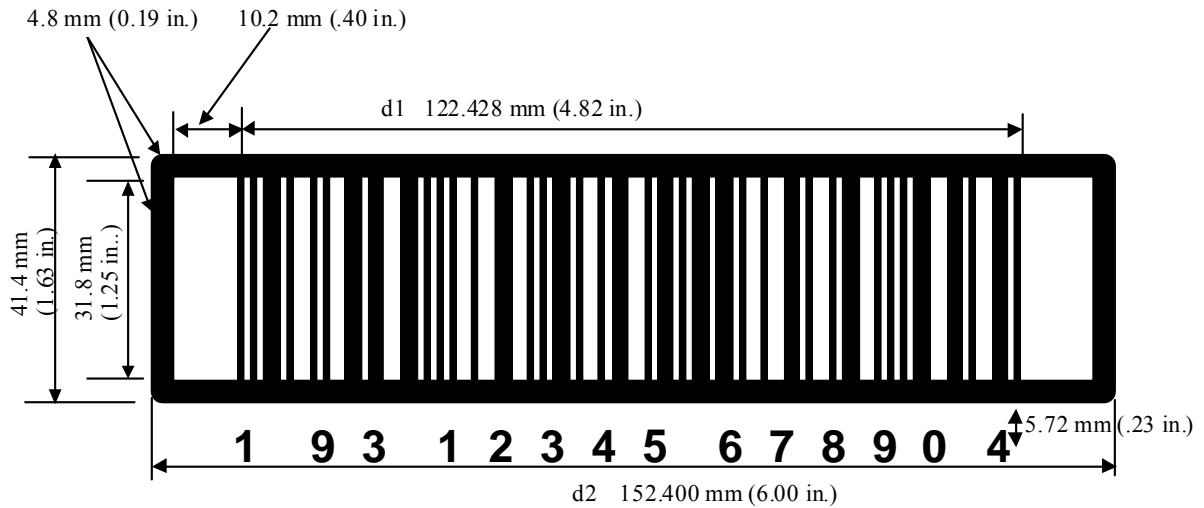
**2.25 <N < 3.00**

N is calculated for each symbol character (pair of data digits) according to the following rule:

$$N_i = 1.5 * [(b_4 + b_5 + s_4 + s_5) / (b_1 + b_2 + b_3 + s_1 + s_2 + s_3)]$$

The value N for the profile is then obtained by averaging the  $N_i$  for all characters in the symbol.

**Figure 5.3.1.9 - 1 ITF-14 Symbol: Main Dimensions at X-Dimension 1.016 mm (0.040 in.)**



**Note:** This diagram is not intended to be used as a basis for measurement.

## 5.4. Linear Bar Codes - GS1-128 Symbology Specifications

The GS1-128 Bar Code Symbol has been carefully designed through joint co-operation between GS1 and Automatic Identification Manufacturers, Inc. (AIM). Use of GS1-128 Bar Code Symbols provides a high degree of security and distinguishes GS1 System Element Strings from extraneous non-standard bar code symbols.

The GS1-128 Symbology is a subset of the more general Code 128 Symbology. By agreement between AIM, Inc. and GS1, use of the Function 1 Symbol Character (FNC1) in Code 128 Symbols in the first symbol character position following the Start Character has been reserved exclusively for the GS1 System.

Code 128 is fully described in *ISO/IEC 15417, Information Technology - Automatic Identification and Data Capture Techniques - Bar code Symbology Specification - Code 128*.

The information covered in Section 5.4 includes:

- Sections [5.4.1](#), [5.4.2](#), [5.4.3](#), [5.4.4](#), [5.4.5](#), and [5.4.6](#): GS1-128 Symbology subset (using *ISO/IEC 15417* for reference)
- Section [5.4.7](#): GS1 System application-defined parameters
- Appendix [5.9](#): GS1 System rules for encoding/decoding Element Strings in GS1 Symbologies using GS1 Application Identifiers

### 5.4.1. GS1-128 Symbology Characteristics

The characteristics of the GS1-128 Symbology are:

- Encodable character set:
  - The Code 128 ASCII characters are in accordance with *ISO/IEC 646*. Refer to Figure 7.12 - 1 for more details. Spaces are not encoded in GS1-128 Bar Code Symbols.
  - Characters with ASCII values 128 to 255 may also be encoded in Code 128 Symbols. Characters with ASCII values 128 to 255 accessed by Function 4 Symbol Character (FNC4) are reserved for future use and are not used in GS1-128 Bar Code Symbols.

- Four non-data function characters. FNC2 and FNC4 are not used in GS1-128 Bar Code Symbols.
  - Four code set selection characters (including single character code set shift)
  - Three Start Characters
  - One Stop Character
- Continuous code type
- Six elements per symbol character comprising three bars (dark bars) and three spaces (light bars), each one, two, three, or four modules in width. The Stop Character is made up of seven elements comprising four bars (dark bars) and three spaces (light bars).
- Character self-checking
- Variable symbol length
- Bi-directionally decodable
- One mandatory Symbol Check Character (see Section 5.4.8.8).
- Data character density is 11 modules per symbol character (5.5 modules per numeric character in code set C, 13 modules per Stop Character)
- Non-data overhead:
  - GS1-128 Bar Code Symbols have a special double character start pattern consisting of the appropriate Start Character and immediately followed by a Function 1 Symbol Character Code (FNC1). The FNC1 adds to the symbol's non-data overhead. The total symbol overhead is 46 modules.
  - The FNC1 character may also be used as a Separator Character between Element Strings not contained in the pre-defined table shown in Figure 5.4.8.2.1 – 1.
- GS1-128 Bar Code Symbol size characteristics:
  - The maximum physical length is 165 millimetres (6.5 inch) including Quiet Zones.
  - The maximum number of data characters in a single symbol is 48.
  - For a given length of data, the symbol size is variable between limits in X-dimension to accommodate the ranges in quality achievable by the various printing processes.

### 5.4.2. GS1-128 Bar Code Symbol Structure

The GS1-128 Bar Code Symbol is made up as follows, reading from left to right:

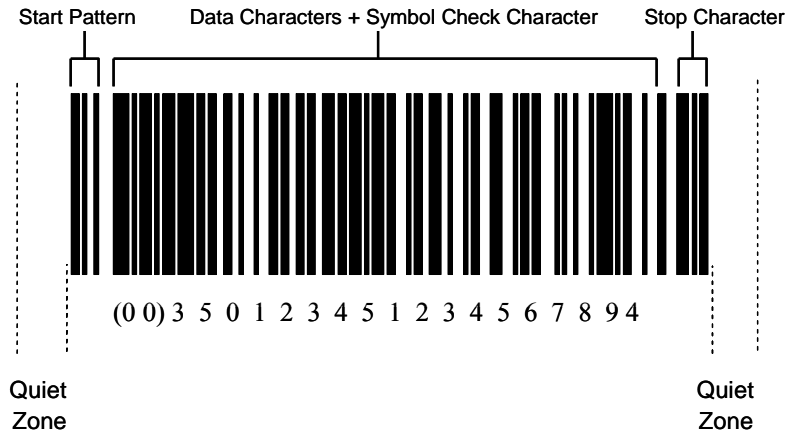
- Left Quiet Zone

A Start Character (A, B, or C)	The Double Character
The Function 1 Symbol Character (FNC1)	Start Pattern

- Data (including the Application Identifier represented in character set A, B, or C)
- A Symbol Check Character
- The Stop Character
- Right Quiet Zone

The data characters represented in the symbol are shown in Human Readable Interpretation underneath or above the symbol.

**Figure 5.4.2 - 1 General Format of a GS1-128 Bar Code Symbol**



### 5.4.3. GS1-128 Symbology Character Assignments

Figure 5.4.3.2 – 1 defines all the Code 128 character assignments. In the element width column, the numeric values represent the widths of the elements in modules or multiples of the X-dimension.

GS1-128 Bar Code Symbol character assignments are identical to Code 128 Symbol character assignments.

#### 5.4.3.1. Symbol Character Structure

The sum of the bar modules in any symbol character is always even (even parity) and the sum of the space modules is, therefore, always odd. This parity feature enables character self-checking.

**Figure 5.4.3.1 - 1 GS1-128 Bar Code Symbol Start Character A**

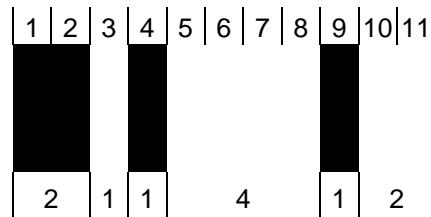
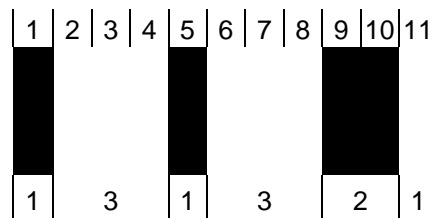


Figure 5.4.3.1 - 2 illustrates the encoding of the symbol character value 35, which represents data character C in code sets A or B or the digits 35 in code set C.

**Figure 5.4.3.1 - 2 Symbol Character Value 35**







Symbol Character Value	Code Set A	ASCII Value for Code Set A	Code Set B	ASCII Value for Code Set B	Code Set C	Element Widths (Modules)						Element Pattern													
						B	S	B	S	B	S	1	2	3	4	5	6	7	8	9	10	11			
38	F	70	F	70	38	1	3	2	3	1	1	■				■	■	■						■	
39	G	71	G	71	39	2	1	1	3	1	3	■	■			■					■				
40	H	72	H	72	40	2	3	1	1	1	3	■	■				■				■				
41	I	73	I	73	41	2	3	1	3	1	1	■	■				■							■	
43	J	74	J	74	42	1	1	2	1	3	3	■		■	■			■	■	■					
43	K	75	K	75	43	1	1	2	3	3	1	■		■	■				■	■	■				
44	L	76	L	76	44	1	3	2	1	3	1	■				■	■	■	■	■					
45	M	77	M	77	45	1	1	3	1	2	3	■		■	■			■	■						
46	N	78	N	78	46	1	1	3	3	2	1	■		■	■						■	■			
47	O	79	O	79	47	1	3	3	1	2	1	■				■	■	■			■	■			
48	P	80	P	80	48	3	1	3	1	2	1	■	■	■			■	■	■				■		
49	Q	81	Q	81	49	2	1	1	3	3	1	■	■			■				■	■	■			
50	R	82	R	82	50	2	3	1	1	3	1	■	■				■			■	■	■			
51	S	83	S	83	51	2	1	3	1	1	3	■	■			■	■	■					■		
52	T	84	T	84	52	2	1	3	3	1	1	■				■	■						■		
53	U	85	U	85	53	2	1	3	1	3	1	■	■			■	■	■					■		
54	V	86	V	86	54	3	1	1	1	2	3	■	■	■			■			■	■				
55	W	87	W	87	55	3	1	1	3	2	1	■	■	■			■						■		
56	X	88	X	88	56	3	3	1	1	2	1	■	■	■				■			■	■			
57	Y	89	Y	89	57	3	1	2	1	1	3	■	■	■			■			■	■				
58	Z	90	Z	90	58	3	1	2	3	1	1	■	■	■			■						■		
59	[	91	[	91	59	3	3	2	1	1	1	■	■	■				■	■				■		
60	\	92	\	92	60	3	1	4	1	1	1	■	■	■			■	■	■				■		
61	]	93	]	93	61	2	2	1	4	1	1	■	■				■						■		
62	^	94	^	94	62	4	3	1	1	1	1	■	■	■	■					■	■				
63	_	95	_	95	63	1	1	1	2	2	4	■		■			■	■	■						
64	NUL	00	grave accent	96	64	1	1	1	4	2	2	■		■						■	■				
65	SOH	01	a	97	65	1	2	1	1	2	4	■			■			■	■						
66	STX	02	b	98	66	1	2	1	4	2	1	■			■								■	■	■

Symbol Character Value	Code Set A	ASCII Value for Code Set A	Code Set B	ASCII Value for Code Set B	Code Set C	Element Widths (Modules)						Element Pattern												
						B	S	B	S	B	S	1	2	3	4	5	6	7	8	9	10	11		
67	ETX	03	c	99	67	1	4	1	1	2	2	■					■		■	■				
68	EOT	04	d	100	68	1	4	1	2	2	1	■					■			■	■			
69	ENQ	05	e	101	69	1	1	2	2	1	4	■		■	■			■						
70	ACK	06	f	102	70	1	1	2	4	1	2	■		■	■					■				
71	BEL	07	g	103	71	1	2	2	1	1	4	■			■	■			■					
72	BS	08	h	104	72	1	2	2	4	1	1	■			■	■					■			
73	HT	09	i	105	73	1	4	2	1	1	2	■				■	■			■				
74	LF	10	j	106	74	1	4	2	2	1	1	■				■	■				■			
75	VT	11	k	107	75	2	4	1	2	1	1	■	■				■					■		
76	FF	12	l	108	76	2	2	1	1	1	4	■	■			■	■							
77	CR	13	m	109	77	4	1	3	1	1	1	■	■	■	■	■	■	■	■	■	■	■	■	■
78	SO	14	n	110	78	2	4	1	1	1	2	■	■				■			■				
79	SI	15	o	111	79	1	3	4	1	1	1	■				■	■	■	■	■	■	■	■	■
80	DLE	16	p	112	80	1	1	1	2	4	2	■		■			■	■	■	■	■	■	■	■
81	DC1	17	q	113	81	1	2	1	1	4	2	■			■	■	■	■	■	■	■	■	■	■
82	DC2	18	r	114	82	1	2	1	2	4	1	■			■	■	■	■	■	■	■	■	■	■
83	DC3	19	s	115	83	1	1	4	2	1	2	■		■	■	■	■	■	■	■	■	■	■	■
84	DC4	20	t	116	84	1	2	4	1	1	2	■			■	■	■	■	■	■	■	■	■	■
85	NAK	21	u	117	85	1	2	4	2	1	1	■			■	■	■	■	■	■	■	■	■	■
86	SYN	22	v	118	86	4	1	1	2	1	2	■	■	■	■	■	■	■	■	■	■	■	■	■
87	ETB	23	w	119	87	4	2	1	1	1	2	■	■	■	■	■	■	■	■	■	■	■	■	■
88	CAN	24	x	120	88	4	2	1	2	1	1	■	■	■	■	■	■	■	■	■	■	■	■	■
89	EM	25	y	121	89	2	1	2	1	4	1	■	■			■	■	■	■	■	■	■	■	■
90	SUB	26	z	122	90	2	1	4	1	2	1	■	■			■	■	■	■	■	■	■	■	■
91	ESC	27	{	123	91	4	1	2	1	2	1	■	■	■	■	■	■	■	■	■	■	■	■	■
92	FS	28		124	92	1	1	1	1	4	3	■		■		■	■	■	■	■	■	■	■	■
93	GS	29	}	125	93	1	1	1	3	4	1	■		■			■	■	■	■	■	■	■	■
94	RS	30	~	126	94	1	3	1	1	4	1	■				■	■	■	■	■	■	■	■	■
95	US	31	DEL	127	95	1	1	4	1	1	3	■		■	■	■	■	■	■	■	■	■	■	■
96	FNC3		FNC3		96	1	1	4	3	1	1	■		■	■	■	■	■	■	■	■	■	■	■

Symbol Character Value	Code Set A	ASCII Value for Code Set A	Code Set B	ASCII Value for Code Set B	Code Set C	Element Widths (Modules)						Element Pattern										
						B	S	B	S	B	S	1	2	3	4	5	6	7	8	9	10	11
97	FNC2		FNC2		97	4	1	1	1	1	3	[Pattern: 4 bars of width 4, 1 space of width 1, 1 bar of width 1, 1 space of width 1, 1 bar of width 3, 1 space of width 1]										
98	SHIFT		SHIFT		98	4	1	1	3	1	1	[Pattern: 4 bars of width 4, 1 space of width 1, 1 bar of width 1, 3 bars of width 1, 1 space of width 1, 1 bar of width 1]										
99	CODE C		CODE C		99	1	1	3	1	4	1	[Pattern: 1 bar of width 1, 1 space of width 1, 3 bars of width 1, 1 space of width 1, 4 bars of width 1, 1 space of width 1]										
100	CODE B		FNC4		CODE B	1	1	4	1	3	1	[Pattern: 1 bar of width 1, 1 space of width 1, 4 bars of width 1, 1 space of width 1, 3 bars of width 1, 1 space of width 1]										
101	FNC4		CODE A		CODE A	3	1	1	1	4	1	[Pattern: 3 bars of width 1, 1 space of width 1, 1 bar of width 1, 1 space of width 1, 4 bars of width 1, 1 space of width 1]										
102	FNC1		FNC1		FNC1	4	1	1	1	3	1	[Pattern: 4 bars of width 1, 1 space of width 1, 1 bar of width 1, 1 space of width 1, 3 bars of width 1, 1 space of width 1]										
103			Start A			2	1	1	4	1	2	[Pattern: 2 bars of width 1, 1 space of width 1, 1 bar of width 1, 4 bars of width 1, 1 space of width 1, 2 bars of width 1]										
104			Start B			2	1	1	2	1	4	[Pattern: 2 bars of width 1, 1 space of width 1, 1 bar of width 1, 2 bars of width 1, 1 space of width 1, 4 bars of width 1]										
105			Start C			2	1	1	2	3	2	[Pattern: 2 bars of width 1, 1 space of width 1, 1 bar of width 1, 2 bars of width 1, 3 bars of width 1, 2 bars of width 1]										

Symbol Character Values	Code Set A	Code Set B	Code Set C	Element Widths (Modules)								Element Pattern												
				B	S	B	S	B	S	B	S	1	2	3	4	5	6	7	8	9	10	11	12	13
	Stop			2	3	3	1	1	1	2	[Pattern: 2 bars of width 2, 3 bars of width 3, 3 bars of width 3, 1 space of width 1, 1 bar of width 1, 1 space of width 1, 2 bars of width 2]													

**Note:** The Stop Character comprises 13 modules in four bars (dark bars) and three spaces (light bars). Every other character comprises 11 modules, starts with a bar (dark bar), ends with a space (light bar), and comprises six elements, each of which varies from one to four modules in width. The numeric values in the B and S columns represent the number of modules in each bar (dark bar) or space (light bar) element respectively in the symbol characters

### 5.4.3.3. Code Sets

This section contains information on Code Sets

#### 5.4.3.3.1. Code Set A

Code set A includes all of the standard upper case alphanumeric characters and punctuation characters together with the symbology elements (e.g., characters with ASCII values from 00 to 95) and seven special characters.

#### 5.4.3.3.2. Code Set B

Code set B includes all of the standard upper case alphanumeric characters and punctuation characters together with the lowercase alphabetic characters (e.g., ASCII characters 32 to 127 inclusive) and seven special characters.

#### 5.4.3.3.3. Code Set C

Code set C includes the set of 100 digit pairs from 00 to 99 inclusive, as well as three special characters. This allows numeric data to be encoded as two data digits per symbol character.

#### 5.4.3.4. Special Characters

The last seven characters of code sets A and B (character values 96 to 102) and the last three characters of code set C (character values 100 to 102) are special non-data characters that, though they have particular significance to the bar code reader, have no ASCII character equivalents.

##### 5.4.3.4.1. Code Set and Shift Characters

Code set and shift characters shall be used to change from one code set to another within a symbol. The decoder shall not transmit them.

- Code set characters: Code A, B, or C characters change the symbol code set from the code set previously defined to the new code set, which is defined by the code character. This change applies to all characters following the code set character until either the end of the symbol, another code set character, or the shift character is encountered.
- Shift character: The shift character changes the code set from A to B or B to A for the single character following the shift character. Characters following the affected character shall revert to the code set A or B defined prior to the shift character.

##### 5.4.3.4.2. Function Characters

Function Characters (FNC) provide special operations and application instructions to the bar code reading device.

- The Function 1 Symbol Character (FNC1) shall be subject to the special considerations defined in Section 5.4.8.9. An FNC1 in the first position following the Start Character of a Code-128 Symbol is at all times a reserved use, which identifies the GS1 System.
- The Function 2 Character (FNC2) (Message Append) is not used in the GS1 System. It instructs the bar code reader to temporarily store the data from the symbol containing the FNC2 and transmit it as a prefix to the data of the next symbol. This may be used to concatenate several symbols before transmission. This character may occur anywhere in the symbol. Where the sequence of data is significant, provision should be made to ensure reading of the symbols in the correct sequence.
- The Function 3 Character (FNC3) (Initialise) instructs the bar code reader to interpret the data from the symbol containing the FNC3 as instructions for initialisation or reprogramming of the bar code reader. The data from the symbol shall not be transmitted by the bar code reader. This character may occur anywhere in the symbol.
- The Function 4 Character (FNC4) is not used in the GS1 System. In Code 128 Symbols, FNC4 is used to represent an extended ASCII character set (byte values 128 to 255) as specified in ISO 8859-1: Information technology; 8-bit single-byte coded graphical character sets; Part 1: Latin alphabet No.1, or otherwise in an application specification. If a single FNC4 is used, the value 128 is added to the ASCII value of the following data character in the symbol. A shift character may follow the FNC4 if it is necessary to change the code set for the following data character. Subsequent data characters revert to the standard ASCII set. If two consecutive FNC4s are used, the value 128 is added to the ASCII value of the following data characters until two further consecutive FNC4s are encountered or the end of the symbol is reached. If, during this sequence of extended ASCII encodation, a single FNC4 is encountered, it is used to revert to standard ASCII encodation for the next data character only. Shift and code set characters shall have their normal effect during such a sequence. The default reference character set for extended ASCII values 128 to 255 is the corresponding half

of ISO 8859-1, Latin alphabet 1, but application specifications may define or reference alternative sets corresponding to byte values 128 to 255.

#### 5.4.3.5. Start and Stop Characters

- Start Characters A, B, and C define the corresponding code set to be used initially in the symbol.
- The Stop Character is common to all code sets.
- The decoder shall not transmit Start and Stop Characters.

#### 5.4.3.6. Symbol Check Character

The Symbol Check Character shall be included as the last symbol character before the Stop Character. Section 5.4.8.8 defines the algorithm for its calculation. The Symbol Check Character shall not be represented in the Human Readable Interpretation nor shall it be transmitted by the decoder.

#### 5.4.3.7. GS1-128 Symbology Start Pattern

The GS1-128 Symbology has special double character start patterns consisting of Start (A, B, or C) and FNC1. These special Start Characters differentiate GS1-128 Bar Code Symbols from the more generalised Code 128 Symbols.

In other words, a Code 128 Symbol, which begins with one of the GS1-128 Symbology double character start patterns, is always a GS1-128 Bar Code Symbol; a Code 128 Symbol, which does not begin with this start pattern, is never a GS1-128 Bar Code Symbol.

A Function 1 Symbol Character (FNC1) may be the Symbol Check Character (in less than 1 percent of cases). It is also used as a Separator Character, when appropriate, if Application Identifiers (AIs) and their data fields are concatenated into a single bar code.

- Start A begins the GS1-128 Symbol data encodation according to character set A.
- Start B begins the GS1-128 Symbol data encodation according to character set B.

Start C begins the GS1-128 Symbol data encodation according to character set C. Start Character C should always be used when the data inclusive of the AI begins with four or more numeric characters.

#### 5.4.3.8. Relationship of Symbol Character Value to ASCII Value (Informative)

In order to convert symbol character value (S) to ASCII decimal value or vice versa, the following relationships are applicable for code set A and code set B.

- Code set A
  - If:**  $S \leq 63$
  - Then:** ASCII value =  $S + 32$
  - If:**  $64 \leq S \leq 95$
  - Then:** ASCII value =  $S - 64$
- Code set B
  - If:**  $S \leq 95$ ,
  - Then:** ASCII value =  $S + 32$

The resulting values are shown in Figure 5.4.3.2 – 1.

- ✔ **Note:** As described in Section 5.4.3, the Function 4 Character (FNC4) is not used in the GS1 System. However, the presence of FNC4 in Code 128 Symbols has the effect of adding 128 to the ASCII value of the subsequent data character or characters derived from the rules given above.

### 5.4.4. Dimensional Requirements

GS1-128 Bar Code Symbols shall conform to the dimensions in the subsections that follow.

#### 5.4.4.1. Minimum Width of a Module (X-Dimension)

The minimum X-dimension is defined by the application specification and requirements (see Section 5.5), while considering the equipment available for symbol production and scanning. For GS1-128 Bar Code Symbols, the absolute minimum X-dimension is 0.250 millimetre (0.00984 inch). The maximum X-dimension is 1.016 millimetres (0.040 inch). Application specifications stipulate a target and range of the X-dimension.

The X-dimension shall be constant throughout a given symbol.

#### 5.4.4.2. Quiet Zone

The minimum width of the Quiet Zone to the left and right of the GS1-128 Bar Code Symbol is 10x.

#### 5.4.4.3. Maximum Symbol Length

The maximum length of any GS1-128 Bar Code Symbol must be within the following limits:

- The physical length, including Quiet Zones, cannot exceed 165 millimetres (6.5 inches).
- The maximum number of encoded data characters is 48, including the Application Identifier(s) and Function 1 Symbol Character (FNC1) when used as a Separator Character, but excluding the auxiliary characters and the Symbol Check Character.

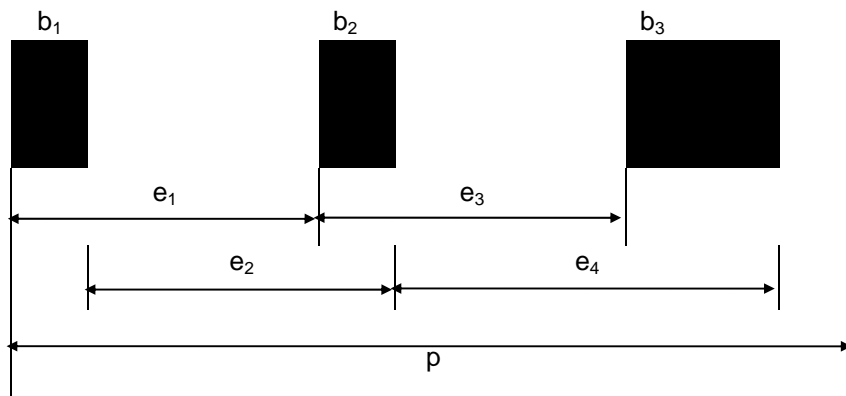
### 5.4.5. Reference Decode Algorithm

Bar code reading systems are designed to read imperfect symbols to the extent that practical algorithms permit. This section describes the reference decode algorithm used in the computation of the decodability value described in *ISO/IEC 15416*.

The algorithm contains the following steps to decode each character:

1. Calculate eight width measurements  $p$ ,  $e_1$ ,  $e_2$ ,  $e_3$ ,  $e_4$ ,  $b_1$ ,  $b_2$ , and  $b_3$  (see Figure 5.4.5 - 1).

**Figure 5.4.5 - 1 Decode Measurements**



2. Convert measurements  $e_1, e_2, e_3,$  and  $e_4$  to normalised values  $e_1, e_2, e_3,$  and  $e_4$ , which will represent the integral module width ( $e_i$ ) of these measurements. The following method is used for the  $i$ -th value:
  - If  $1,5p/11 \leq e_i < 2,5p/11$ , then  $E_i = 2$
  - If  $2,5p/11 \leq e_i < 3,5p/11$ , then  $E_i = 3$
  - If  $3,5p/11 \leq e_i < 4,5p/11$ , then  $E_i = 4$
  - If  $4,5p/11 \leq e_i < 5,5p/11$ , then  $E_i = 5$
  - If  $5,5p/11 \leq e_i < 6,5p/11$ , then  $E_i = 6$
  - If  $6,5p/11 \leq e_i < 7,5p/11$ , then  $E_i = 7$

Otherwise the character is in error.

3. Look up the character in the decode table using the four values  $E_1, E_2, E_3,$  and  $E_4$  as the key (see Figure 5.4.5 – 2).
4. Retrieve the self-checking symbol character value  $V$ , which is stored in the table with the character. The value  $V$  is equal to the sum of the modules for the bars (dark bars) as defined for that character.
5. Verify that:

$$(V-1, 75)p / 11 < (b_1 + b_2 + b_3) < (V + 1, 75)p / 11$$

Otherwise the character is in error.

The calculation indirectly uses character parity to detect all decode errors caused by single non-systematic one-module edge errors.

Using these five steps, decode the first character. If it is a Start Character, continue decoding the symbol in the normal forward direction. If it is not a Start Character but decodes as a Stop Character, attempt to decode all subsequent characters in the reverse direction.

After all characters have been decoded, make sure there is a valid Start Character, a valid Stop Character, and that the Symbol Check Character is correct.

Translate the symbol characters into the appropriate data characters from code set A, B, or C according to the Start Character, code characters, and shift characters used in the symbol.

In addition, perform other secondary checks on Quiet Zones, beam acceleration, absolute timing, and dimensions that are appropriate considering the specific reading device and intended application environment.

**Note:** In this algorithm the symbol is decoded using edge to similar edge measurements ( $e$ ) and an additional measurement of the sum of the three bar (dark bar) widths.

**Figure 5.4.5 – 2 Edge Differences for Decoding Code 128 Symbols**

Char. Value	E1	E2	E3	E4	V	Char. Value	E1	E2	E3	E4	V
00	3	3	4	4	6	54	4	2	2	3	6
01	4	4	3	3	6	55	4	2	4	5	6
02	4	4	4	4	6	56	6	4	2	3	6
03	3	3	3	4	4	57	4	3	3	2	6
04	3	3	4	5	4	58	4	3	5	4	6
05	4	4	3	4	4	59	6	5	3	2	6

Char. Value	E1	E2	E3	E4	V	Char. Value	E1	E2	E3	E4	V
06	3	4	4	3	4	60	4	5	5	2	8
07	3	4	5	4	4	61	4	3	5	5	4
08	4	5	4	3	4	62	7	4	2	2	6
09	4	3	3	3	4	63	2	2	3	4	4
10	4	3	4	4	4	64	2	2	5	6	4
11	5	4	3	3	4	65	3	3	2	3	4
12	2	3	4	5	6	66	3	3	5	6	4
13	3	4	3	4	6	67	5	5	2	3	4
14	3	4	4	5	6	68	5	5	3	4	4
15	2	4	5	4	6	69	2	3	4	3	4
16	3	5	4	3	6	70	2	3	6	5	4
17	3	5	5	4	6	71	3	4	3	2	4
18	4	5	5	3	6	72	3	4	6	5	4
19	4	3	2	4	6	73	5	6	3	2	4
20	4	3	3	5	6	74	5	6	4	3	4
21	3	4	5	3	6	75	6	5	3	3	4
22	4	5	4	2	6	76	4	3	2	2	4
23	4	3	3	4	8	77	5	4	4	2	8
24	4	2	3	4	6	78	6	5	2	2	4
25	5	3	2	3	6	79	4	7	5	2	6
26	5	3	3	4	6	80	2	2	3	6	6
27	4	3	4	3	6	81	3	3	2	5	6
28	5	4	3	2	6	82	3	3	3	6	6
29	5	4	4	3	6	83	2	5	6	3	6
30	3	3	3	3	6	84	3	6	5	2	6
31	3	3	5	5	6	85	3	6	6	3	6
32	5	5	3	3	6	86	5	2	3	3	6
33	2	2	4	5	4	87	6	3	2	2	6
34	4	4	2	3	4	88	6	3	3	3	6
35	4	4	4	5	4	89	3	3	3	5	8
36	2	3	5	4	4	90	3	5	5	3	8
37	4	5	3	2	4	91	5	3	3	3	8
38	4	5	5	4	4	92	2	2	2	5	6
39	3	2	4	4	4	93	2	2	4	7	6
40	5	4	2	2	4	94	4	4	2	5	6
41	5	4	4	4	4	95	2	5	5	2	6

Char. Value	E1	E2	E3	E4	V		Char. Value	E1	E2	E3	E4	V
42	2	3	3	4	6		96	2	5	7	4	6
43	2	3	5	6	6		97	5	2	2	2	6
44	4	5	3	4	6		98	5	2	4	4	6
45	2	4	4	3	6		99	2	4	4	5	8
46	2	4	6	5	6		100	2	5	5	4	8
47	4	6	4	3	6		101	4	2	2	5	8
48	4	4	4	3	8		102	5	2	2	4	8
49	3	2	4	6	6		103	3	2	5	5	4
50	5	4	2	4	6		104	3	2	3	3	4
51	3	4	4	2	6		105	3	2	3	5	6
52	3	4	6	4	6		Stop <sub>A</sub>	5	6	4	2	6
53	3	4	4	4	8		Stop <sub>B</sub>	3	2	2	4	6

- Note:** Stop<sub>A</sub> values are for decoding in a forward direction. Stop<sub>B</sub> values apply to the first six elements of the Stop Character starting at the rightmost side when scanned in a reverse direction.

### 5.4.6. Symbol Quality

*ISO/IEC 15416* defines a standardised methodology for measuring and grading bar code symbols. Code 128 Symbols shall be evaluated according to that standard. The reference decode algorithm defined in Section 5.3.1.4 shall be used for the assessment of the decode and decodability parameters under *ISO/IEC 15416*.

- Note:** For GS1-128 Bar Code Symbol minimum quality levels, refer to Section [5.4.7](#).

#### 5.4.6.1. General

#### 5.4.6.2. Decodability

Decodability is a measure of how closely the decode algorithm measurement values approach those in a theoretically perfect symbol. Thus, decodability is a parameter that measures how closely the Scan Reflectance Profile is to approaching decode failure for a given printed symbol.

For the calculation of the decodability value *V*, the following provisions apply, which supplement those described in *ISO/IEC 15416* for edge to similar edge decodable symbologies:

**Substitute V1 for VC in the formula  $VC = K / (S / 2n)$**

- Where:
  - K** = the smallest difference between a measurement and a reference threshold
  - N** = 11 (number of modules in a symbol character)
  - S** = total width of the character

### Calculate V2

$$1,75 - (\text{ABS}((\text{Wb} \times 11/\text{S}) - \text{M}))$$

$$\text{V2} =$$

$$1,75$$

Where: **M** = number of dark modules in the character

**S** = total width of the character

**Wb** = sum of the bar (dark bar) widths in the character

**ABS** = mathematical term for taking the absolute of the calculation that follows it

VC is the lesser of V1 and V2.

The Stop Character includes an additional terminating bar (dark bar). For the purpose of measuring decodability, the Stop Character should be checked twice: first using the six leftmost elements and then using the six rightmost elements from right to left. Both sets of six elements are equivalent in width to a standard character.

#### 5.4.6.3. Quiet Zone Measurement

The Quiet Zones to the right and left of the GS1-128 Bar Code Symbol are compulsory. Both Quiet Zones have a minimum width of 10x.

*ISO/IEC 15416* allows for additional pass/fail criteria to be stipulated by a symbology specification. In the case of a GS1-128 Bar Code Symbol, a minimum Quiet Zone of 10Z is specified. Both left and right Quiet Zones on each Scan Reflectance Profile (SRP) under *ISO/IEC 15416* shall be measured and graded as follows:

Quiet Zone  $\geq$  10Z: Grade 4 (A)

Quiet Zone < 10Z: Grade 0 (F)

Where Z = the average measured width of the narrow bars (dark bars) and spaces (light bars) (one module) in the symbol

#### 5.4.6.4. Transmitted Data

Transmitted data from a decoded GS1-128 Bar Code Symbol shall comprise the byte values of the data characters. It is prefixed by the symbology identifier ]C1, if used. The Start and Stop Characters, function characters, code set and shift characters, and Symbol Check Character shall not be included in the transmitted data.



**Note:** For GS1-128 Symbology implementation, see Section [5.4.7](#).

### 5.4.7. GS1-128 Symbology Application Parameters

#### 5.4.7.1. Symbol Height

For GS1-128 Bar Code Symbols used in general distribution, the minimum height of the bars (dark bars) in the symbol is 32 millimetres (1.25 inches). The actual symbol height used depends on the specific application requirements.

### 5.4.7.2. Symbol Length

The dimensions of the GS1-128 Bar Code Symbol depend on the number of characters encoded:

1 Start Character x 11 modules = 11

Function 1 Symbol Character (FNC1) x 11 modules = 11

1 Symbol Check Character x 11 modules = 11

1 Stop Character x 13 modules = 13

N symbol characters x 11 modules = 11N

#### **(11N + 46) modules**

Where N is the number of symbol characters, any auxiliary characters (shift and code characters) embedded in the data are included.

A module is equal to the X-dimension of the symbol.

Character set C allows two digits to be encoded in one symbol character. Thus, numeric data can be encoded with twice the density of other data when using character set C.

In addition, Quiet Zones to the right and left of the bar code are compulsory and both have widths of 10 modules.

Thus total symbol length, including Quiet Zones, is: **(11N + 66) modules = (11N + 66) x**

### 5.4.7.3. Maximum Symbol Length

Two parameters have to be taken into consideration for defining the maximum length of a GS1-128 Bar Code Symbol: the physical length, which depends on the number of characters encoded and the module width (or X-dimension) used, and the number of data characters encoded excluding the auxiliary characters.

The maximum length of any GS1-128 Bar Code Symbol must be within the following limits:

**The physical length, including Quiet Zones, cannot exceed 165 millimetres (6.5 inches).**

The maximum number of encoded data characters is 48, including the Application Identifier(s) and Function 1 Symbol Character (FNC1) when used as a Separator Character, but excluding the auxiliary characters and the Symbol Check Character.

### 5.4.7.4. Human Readable Interpretation

The Human Readable Interpretation of the data in the bar code symbol must be shown below the symbol. Start, Stop, shift, and function characters, as well as the Symbol Check Character, are not shown in the human readable format.

The precise location of the Human Readable Interpretation and the font used to represent the characters are not specified for GS1-128 Bar Code Symbols. However, the characters should be clearly legible (such as OCR-B) and must be obviously associated with the symbol. The Quiet Zones must not be violated.

Application Identifiers should be clearly recognisable to facilitate key entry. This is achieved by putting parentheses around Application Identifiers in the Human Readable Interpretation.



**Note:** The parentheses are not part of the data and are not encoded in the bar code symbol.

### 5.4.7.5. Transmitted Data (FNC1)

The following GS1-128 Symbology implementation specifications are in accordance with *ISO/IEC 15417 Appendix 2* for transmitted data:

- The Function 1 Symbol Character (FNC1) may validly occur as the Symbol Check Character.
- FNC1 in the third or subsequent character position is transmitted as the ASCII character 29 (GS).
- Symbols using FNC1 in the first data position should have symbology identifiers enabled.

When FNC1 is used in the first position it shall not be represented in the transmitted message, although its presence is indicated by the use of modifier value 1 in the symbology identifier.

### 5.4.7.6. Additional Features of Code 128 (Normative)

#### 5.4.7.6.1. Symbol Check Character

The Code 128 Symbol Check Character shall be calculated according to the following rules.

1. Retrieve the symbol character value from Figure 5.4.3.2 - 1.
2. Each symbol character position is given a weight. The Start Character is weighted 1. Then, beginning on the left with the first symbol character following the Start Character, the weights are 1, 2, 3, and 4 to...n for all subsequent symbol characters up to, but not including, the Symbol Check Character itself; n denotes the number of symbol characters representing data or special information in the symbol, exclusive of the Start and Stop Characters and Symbol Check Character.

**Note:** Both the Start Character and the first symbol character following the Start Character (the Function 1 Symbol Character (FNC1) for all GS1-128 Bar Code Symbols) are weighted by one.

3. Each symbol character value is multiplied by its weight.
4. The products of the calculations in step 3 are totalled.
5. The sum of the products is divided by 103.
6. The remainder derived from the calculation in step 5 is the symbol character value of the Symbol Check Character.

Figure 5.4.8.8.1 - 1 shows how to calculate the Symbol Check Character value for the batch number 2503X using the GS1-128 Bar Code Symbol.

**Figure 5.4.8.8.1 - 1**

Start C FNC1 10\* 25 03 Code B X [Symbol Check Character] Stop

Characters	Start C	FNC1	10	25	03	Code B	X
Character values (Step 1)	105	102	10	25	3	100	56
Weights (Step 2)	1	1	2	3	4	5	6
Products (Step 3)	105	102	20	75	12	500	336
Sum of products (Step 4)		1150					
Divide by 103 (Step 5)		1150 / 103 = 11					
Remainder = Symbol Check Character value		17					

\* Application Identifier (10) is defined as batch or lot number.

The Symbol Check Character shall be positioned immediately following the final data or special character and before the Stop Character.



**Note:** The Symbol Check Character shall not be shown in the Human Readable Interpretation.

#### 5.4.7.7. Use of Start, Code Set, and Shift Characters to Minimize Symbol Length (Informative)

The same data may be represented by different GS1-128 Bar Code Symbols through the use of different combinations of Start, code set, and shift characters.

The following rules should normally be implemented in printer control software to minimise the number of symbol characters needed to represent a given data string (and, therefore, reduce the overall symbol length).

1. Determine the Start Character:
  - a. If the data consists of two digits, use Start Character **C**.
  - b. If the data begins with four or more numeric data characters, use Start Character **C**.
  - c. If an ASCII symbology element (e.g., NUL) occurs in the data before any lowercase character, use Start Character **A**.
  - d. Otherwise, use Start Character **B**.
2. If **Start Character C** is used and the data begins with an odd number of numeric data characters, insert a code set **A** or code set **B** character before the last digit, following rules 1c and 1d to determine between code sets **A** and **B**.
3. If four or more numeric data characters occur together when in code sets **A** or **B** and:
  - e. If there is an even number of numeric data characters, then insert a code set **C** character before the first numeric digit to change to code set **C**.
  - f. If there is an odd number of numeric data characters, then insert a code set **C** character immediately after the first numeric digit to change to code set **C**.
4. When in code set **B** and an ASCII symbology element occurs in the data:
  - g. If following that character, a lowercase character occurs in the data before the occurrence of another symbology element, then insert a shift character before the symbology element.
  - h. Otherwise, insert a code set **A** character before the symbology element to change to code set **A**.
5. When in code set **A** and a lowercase character occurs in the data:
  - i. If following that character, a symbology element occurs in the data before the occurrence of another lowercase character, then insert a shift character before the lowercase character.
  - j. Otherwise, insert a code set **B** character before the lowercase character to change to code set **B**.
6. When in code set **C** and a non-numeric character occurs in the data, insert a code set **A** or code set **B** character before that character, and follow rules 1c and 1d to determine between code sets **A** and **B**.



**Note:** In these rules, the term “lowercase” is used for convenience to mean any code set **B** character with Code 128 Symbol character values 64 to 95 (ASCII values 96 to 127) (e.g., all lowercase alphanumeric characters plus `{ } ~ DEL). The term “symbology element” means any code set **A** character with Code 128 Symbol character values 64 to 95 (ASCII values 00 to 31).

- ✓ **Note:** If the Function 1 Symbol Character (FNC1) occurs in the first position following the Start Character, or in an odd-numbered position in a numeric field, it should be treated as two digits for the purpose of determining the appropriate code set.

#### 5.4.7.8. Guidelines for the Use of Code 128 (Informative)

##### 5.4.7.8.1. Autodiscrimination Compatibility

Code 128 Symbols may be read by suitably programmed bar code readers that have been designed to autodiscriminate these symbols from other symbologies. Code 128 Symbology is fully distinguishable from and compatible with the following linear symbologies:

- ITF (Interleaved 2 of 5)
- Codabar
- Code 39
- Code 93
- EAN/UPC
- Telepen
- GS1 DataBar

## 5.5. Bar Code Production and Quality Assessment

### 5.5.1. Introduction

This section has been evolving to meet the changes to data carriers and their use within the GS1 System. Some of those changes are, for example, dimension requirements, the introduction of new symbols (e.g., GS1 DataBar (formerly RSS) and Composite Component), and the shift from the use of analogue Film Masters to digital bar code files.

Consideration should be given to how these changes affect bar code symbol production and the maintenance of quality in the production process.

### 5.5.2. GS1 System Symbol Specification Tables

Over the years, operational requirements of GS1 System users have influenced the dimensional specifications of GS1 System symbols, and these dimensional specifications have in turn influenced the development of scanning system optics and printing processes. The GS1 System Symbol Specification Tables (SSTs) relate to the application areas defined in Section 2. Each SST provides the following bar code symbol specification detail:

- The bar code symbol(s) specified by the GS1 System for each application area
- The minimum, target, and maximum X-dimension (narrow element width) for the symbol, based on the scanning environment
- The minimum and target bar code symbol height, based on the scanning environment
- The Quiet Zone width and, for primary/secondary symbols, the minimum and maximum separation between the two symbols

- ✓ **Note:** These measurements are expressed as multiples of the X-dimension in the form  $nX$ .

- The minimum ISO quality specification
  - ✔ **Note:** Expressed as **g.g/aa/www**, where **g.g** is the minimum overall symbol grade to one decimal place (on a 4.0 scale), **aa** is the effective measuring aperture in thousandths of an inch, and **www** is the wavelength of the light source in nanometres.
  - ✔ **Note:** Please refer to Section 2 for any specific application guidelines (such as Section 2.1.3, Fixed Measure - Very Small Healthcare Items, and Section 2.1.5, Fixed Measure - Direct Part Marking) that may supplement or supersede these symbol specification tables for specific application areas.

Before determining the exact symbol specification required, additional factors, such as scanning environment, should be considered. These are summarised in Section [5.5.2.1](#).

#### 5.5.2.1. Role of the Symbol's Dimensional Specifications

The three major dimensional specifications are the symbol's nominal (target) X-dimension, the symbol's allowable X-dimension range, and the symbol's minimum bar height. These dimensional characteristics are always specified based on the operating environment. The X-dimension target and range determine the scanner's operating range (field of view). The bar code symbol's height along with its X-dimension target and range help determine the ergonomic aspects of product handling when using a scanner. These dimensional specifications are critical components of the efficient use of all scanners.

#### 5.5.2.2. Omnidirectional Scanning and the Term Magnification (X-Dimension)

The EAN/UPC Symbology was originally designed for omnidirectional scanners. Based on this type of scanner, the specifications include a fixed relationship between the symbol's nominal (target) width and height. The term "symbol magnification" has been used extensively to refer to this fixed relationship. For example, EAN-13 Symbols have a fixed relationship between the symbol target width and height (100 percent magnification) based on the symbol height (including text) of 25.93 millimetres (1.02 inches) and a target X-dimension of 0.33 millimetre (.013 inch). The term magnification has been used to refer to a range of magnification percentages below and/or above a target value that are specified based on the omnidirectional scanning environment. The Symbol Specification Tables (SSTs) do not use magnification values and instead list the target, minimum, and maximum values for the symbol's X-dimension and height.

#### 5.5.2.3. Laser versus Image Based Scanning

Most scanners based on laser technology can scan all linear symbologies in the GS1 System. New laser and linear array scanners are even capable of scanning GS1 DataBar (formerly RSS) and Composite Component Symbols. 2D Imaging technology, such as array scanners and vision systems, are capable of scanning all symbols in the GS1 System, including GS1 DataMatrix. Note that linear imagers, like laser scanners, cannot scan GS1 DataMatrix; only 2D or array imaging scanners can scan GS1 DataMatrix, as well as camera based or vision systems. For this reason, GS1 DataMatrix applications shall be limited to niche markets and direct part marking where the business case is justified for using this technology exclusively to read GS1 DataMatrix Symbols. For more information, see Section [5.5.2.6](#), on operative scanning environments for GS1 System symbols.

#### 5.5.2.4. Printing Considerations

The functional and operative bands provide printers and labellers with the flexibility needed to produce quality symbols over a wide range of processes. Once a scanning operational environment is

determined and the allowable specification range is known, the printer should be consulted for guidance on:

- The minimum recommended symbol size based on printing press or print characterisation tests
- Colour/substrate considerations (e.g., separate print station for symbol or double ink layer)
- The optimum orientation of the symbol on the printed web (the direction of movement of the media in relation to a printing plate on a printing press)
- Direct part marking, such as is done by dot peening on items, requires special considerations for material properties
- Laser or chemically etched parts with low contrast or light marked elements on a dark background (e.g., circuit boards and electronic components, medical instruments, surgical implants)
- High-speed ink jet printed parts and components where the marked dots cannot form a scannable linear symbol
- Very small items that require a symbology with a square aspect ratio and/or cannot be marked within the allocated packaging space by existing GS1 DataBar (formerly RSS) and Composite symbols

#### 5.5.2.5. Packaging Considerations

Once a scanning operational environment is determined and the allowable symbol characteristics are known, the package designer should be consulted to:

- Ensure the symbol will not be obstructed by other graphics or package design parameters (e.g., folds, creases, corner wraps, flaps, laminates, embossed logos/patterns, text)
- Ensure that only the symbol intended for scanning will be scanned (e.g., obscure all symbols on the individual units within larger trade items so that the individual units' symbols do not scan instead of the larger unit's symbol)

Section 6 contains complete information on symbol placement criteria to meet quality and ergonomic needs.

#### 5.5.2.6. Operative Scanning Environments for GS1 System Symbols

The application where the bar code symbol will be used should be determined prior to locating the correct Symbol Specification Table (SST) entry. Figure 5.5.2.6 - 1 provides a cross-reference for all system applications defined in Section 2. Use the “See SST(s) #” column to find the SST appropriate for the application area. Because most application areas provide a reference to two Symbol Specification Tables based on the operative scanning environment, a decision must be made between the two. See the decision tree in Figure 5.5.2.6.1 - 2 to determine the correct Symbol Specification Table.

**Figure 5.5.2.6 - 1** Areas of GS1 System Application

Application Areas	See Section	See SST(s) #	Read Before Reviewing Symbol Specification Table
Fixed Measure Trade Items – Packages/Containers Scanned at POS	2.1.2.1	1 or 3	EAN-13, UPC-A, EAN-8, and UPC-E Symbols only
Fixed Measure Trade Items – Books and Serials	2.1.2.1.5	1 or 3	EAN-13, UPC-A, EAN-8, and UPC-E Symbols only
Fixed Measure Trade Items – Packages/Containers NOT Scanned at POS	2.1.2.3	2 or 4	

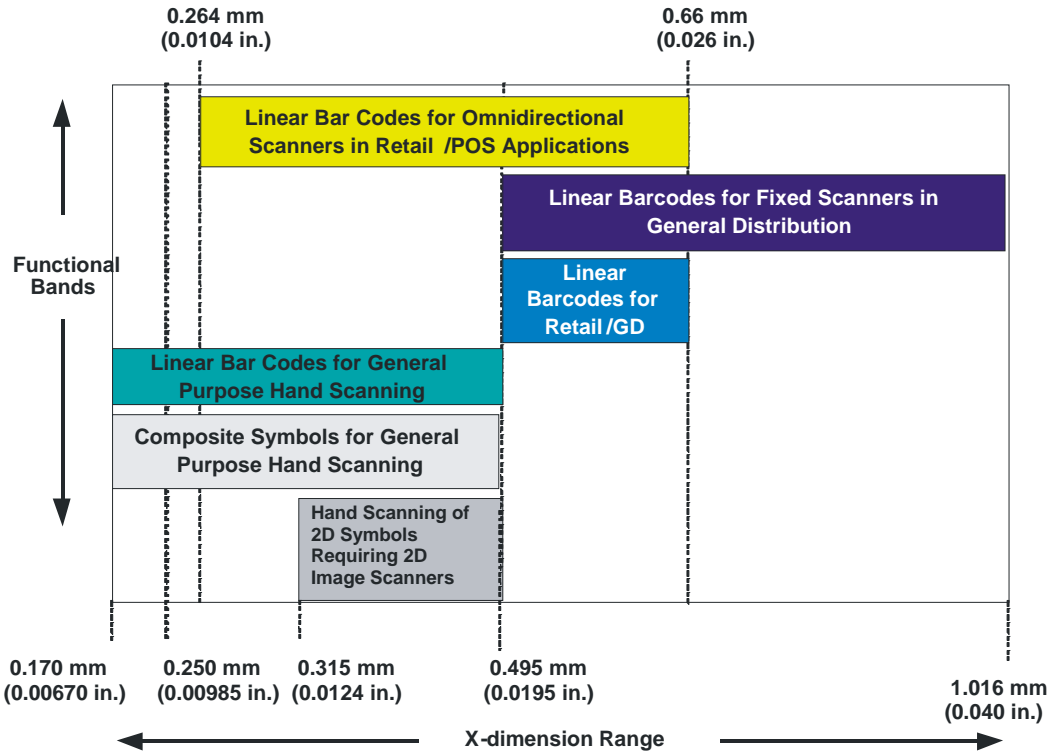
Application Areas	See Section	See SST(s) #	Read Before Reviewing Symbol Specification Table
Fixed Measure Trade Items – Trade Item Packed in Several Physical Units NOT Scanned at POS	2.1.4	2 or 4	GS1-128 Symbols only
Fixed Measure Trade Items – Restricted Distribution	2.1.7	1 or 3	
Variable Measure Trade Items – Restricted Circulation	2.1.8	1	EAN-13 and UPC-A Symbols only
Variable Measure Trade Items – Packages/Containers NOT Scanned at POS	2.1.6	2 or 4	GS1-128 Symbols only
POS Trade Item Attributes – Using Secondary EAN/UPC-2 or EAN/UPC-5 Add-On Symbols	2.1.2.1.5	1	Use the X-dimension specified for the primary EAN/UPC Symbol
Trade Item Attributes – Using Secondary GS1-128 Symbols	2.1.2	2 or 4	Use the X-dimension specified for the primary symbol
Logistics – Mandatory SSCC	2.2.1	5	GS1-128 Symbols only
Logistics – Logistic Unit Element Strings	2.2.1	5	GS1-128 Symbols only
Assets – Global Returnable Asset Identifier	2.3.1	2, 4, or	GS1-128 Symbols only
Assets – Global Individual Asset Identifier	2.3.2	2, 4, or	GS1-128 Symbols only
Locations or Postal Codes	2.4	2 or 4	GS1-128 Symbols only
Global Service Relation Numbers	2.5	4	GS1-128 Symbols only
Coupons – Restricted Geographic Distribution Outside USA or Common Currency Area identification	2.6.3 and 2.6.4	1	EAN-13 Symbols only
Coupons – Restricted Geographic Distribution Inside USA - UPC-A plus GS1-128 Symbols	2.6.5 and 2.6.6	4	See <i>Guidelines for Supply Chain Identification</i>
Refund Receipts – Restricted Geographic Distribution	2.6.7	1	EAN-13 Symbols only
Electronic Serial Identifier for Cellular Mobile Telephones	2.6.8	4	GS1-128 Symbols only
Company Internal Application Using EAN/UPC Symbols	2.1.7 and 2.1.8	1	EAN-13, UPC-A, and UPC-E Symbols only
Internal Application Using GS1-128 Symbols	2.1.7 and 2.1.8	2 or 4	GS1-128 Symbols only
Payment Slips	2.6.9	4	GS1-128 Symbols only
Customer Specific Articles	2.6.10	4	
Very Small Healthcare Items	2.1.3	4, 6 or 7	GS1 DataBar and Composite Component or GS1 DataMatrix Symbols only*
Direct Part Marking	2.1.5	7	GS1 DataMatrix

\* See Section [5.7](#). GS1 DataMatrix has limited use in healthcare until application standards are fully developed.

### 5.5.2.6.1. GS1 System Scanner Functional Operative Bands

GS1 System symbol specifications are based on six scanner functional bands because scanner technology cannot universally support the entire operating range using a single scanner and different application requirements. The six scanner functional bands that have evolved to meet user needs are illustrated in Figure 5.5.2.6.1 - 1.

Figure 5.5.2.6.1 - 1 GS1 Scanner Functional Operative Bands



**Note:** Figure not to scale and target size for each functional band can be found in the Symbol Specification Tables (see Section [5.5.2.7](#))

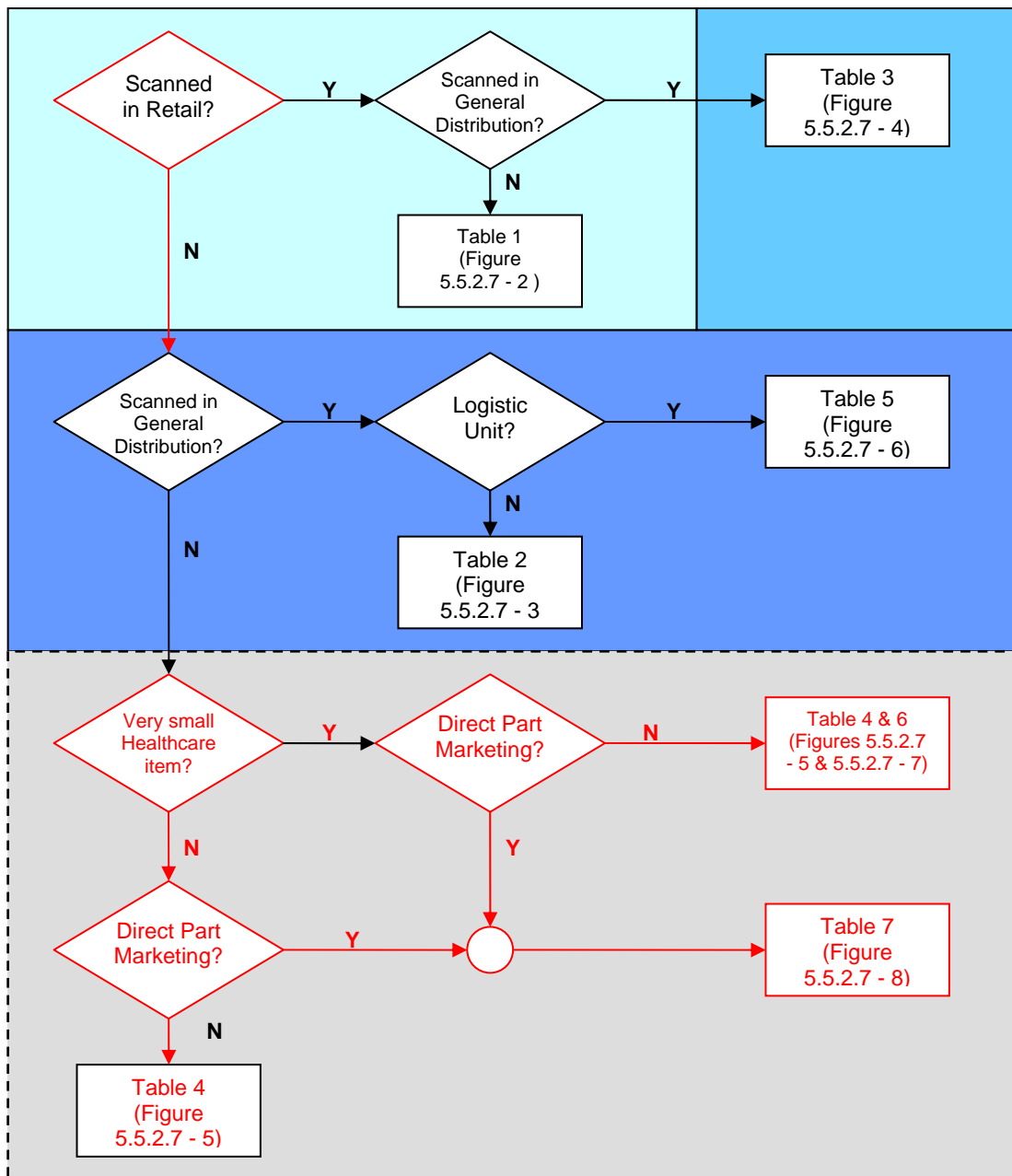
In the future, there will be more integration of the operative bands and an extension of the bands to support small symbols.

#### The Scanner Functional Bands

- The Omnidirectional Scanners for Retail POS band is primarily intended for retail operations to provide orientation-free scanning. Scanners are designed to read EAN/UPC over-square symbols. The approximate average distance between scanner and symbol is 100 millimetres (4 inches).
- The Fixed Scanners in General Distribution band is primarily intended to facilitate automated scanning of trade items packaged for transport and logistic units using fixed mount scanners. In this environment it is essential to maintain symbol height and location to achieve acceptable scan rates.
- Linear bar codes for both Retail and General Distribution band covers trade items in specific packaging suitable for transport purposes in General Distribution Scanning, but that are also scanned at the retail Point-of-Sale. See the overlap area between EAN/UPC Retail and General Distribution (Retail/GD) in Figure 5.5.2.6.1 - 1.

- The General Purpose scanner bands cover a broad range of applications. Symbol size must be within the maximum and minimum boundaries for the symbology, but the target size is directly related to the exact usage as specified by the application guidelines. It has been divided into three bands: One for linear general purpose hand scanning and two bands for two-dimensional bar codes: Composite Component and GS1 DataMatrix. In general, the rule is that Composite Components shall be printed at the same X-dimension as their linear host. GS1 DataMatrix Symbols shall be printed at X-dimensions that are 50 percent greater than corresponding linear symbols with Composite Components. Therefore, the bands for linear symbols and Composite Components are very similar in X-dimension and if the same scanner types are chosen, as in the case of Composite Symbols, the bands become one.

**Figure 5.5.2.6.1 - 2 GS1 Symbology Operational Environment Decision Tree**



### 5.5.2.7. GS1 System Symbol Specification Tables

In order to find the correct bar code specification, you must:

- Find the appropriate GS1 System application area using Figure 5.5.2.6 - 1.
- If the application area references two Symbol Specification Tables, use the decision tree in Figure 5.5.2.6.1 - 2 to determine which one to use.

Figure 5.5.2.7 - 1 provides a quick reference list of the symbol quality parameters depending on their type and their application.

**Figure 5.5.2.7 - 1 Quick Reference on Symbol Quality**

Symbology	Application or ID Code	ISO (ANSI) Symbol Grade	Aperture	Wavelength
EAN/UPC	GTIN-8	1.5 (C)	6 mils	670 nm +/-10
EAN/UPC	GTIN-12	1.5 (C)	6 mils	670 nm +/-10
EAN/UPC	GTIN-13	1.5 (C)	6 mils	670 nm +/-10
GS1-128	Coupon Extended Code	1.5 (C)	6 mils	670 nm +/-10
GS1-128	GTIN-12, GTIN-13, GTIN-14	1.5 (C)	10 mils	670 nm +/-10
GS1-128	SSCC	1.5 (C)	10 mils	670 nm +/-10
GS1-128	Small Shipping Packages	1.5 (C)	10 mils	670 nm +/-10
ITF-14 (<0.635 mm (0.025 in.) X)	GTIN-12, GTIN-13, GTIN-14	1.5 (C)	10 mils	670 nm +/-10
ITF-14 (≥0.635 mm (0.025 in.) X)	GTIN-12, GTIN-13, GTIN-14	0.5 (D)	20 mils	670 nm +/-10
GS1 DataBar and Composite	GTIN-12, GTIN-13, GTIN-14, other AIs	1.5 (C)	6 mils	670 nm +/-10
GS1 DataMatrix	Direct Part Marking, Very Small Healthcare Items	1.5 (C)	See Guidelines (Sections 2.1.5 and 2.1.3)	670 nm +/-10

**Note:** An EAN/UPC-based symbol should always be verified using a 6 millimetres (0.006 inch) aperture, a 670 nanometres +/-10 nanometres wavelength of light, and requires a minimum symbol grade of 1.5 (overall symbol grade on a 4.0 scale) equivalent to a “C” under the ANSI X3.182 standard. In the Symbol Specification Tables that follow, as well as on a typical bar code purchase order, this is expressed as 1.5/06/670.

Figure 5.5.2.7 - 2 GS1 System Symbol Specification Table 1

* Primary Symbol(s) Specified	X-Dimension mm (inches)			*** Minimum Symbol Height for Given X mm (inches)			Quiet Zone				Minimum Quality Specification
	**Minimum	Target	Maximum	For Minimum X-dimension	For Target X-dimension	For Maximum X-dimension	Left		Right		
EAN-13	0.264 (0.0104")	0.33 (0.013")	0.66 (0.026")	20.73 (0.82")	25.91 (1.02")	51.82 (2.04")	11X		7X		1.5/06/670
EAN-8	0.264 (0.0104")	0.33 (0.013")	0.66 (0.026")	17.03 (0.67")	21.29 (0.84")	42.58 (1.68")	7X		7X		1.5/06/670
UPC-A	0.264 (0.0104")	0.33 (0.013")	0.66 (0.026")	20.73 (0.82")	25.91 (1.02")	51.82 (2.04")	9X		9X		1.5/06/670
UPC-E	0.264 (0.0104")	0.33 (0.013")	0.66 (0.026")	20.73 (0.82")	25.91 (1.02")	51.82 (2.04")	9X		7X		1.5/06/670
* Primary Symbol(s) Specified Plus Add-on 2 or 5	X-Dimension mm (inches)			*** Minimum Symbol Height for Given X mm (inches)			Quiet Zone	Min separation between symbols	Max separation between symbols	Quiet Zone	Minimum Quality Specification
	**Minimum	Target	Maximum	For Minimum X-dimension	For Target X-dimension	For Maximum X-dimension					
EAN-13 + 2	0.264 (0.0104")	0.33 (0.013")	0.66 (0.026")	20.73 (0.82")	25.91 (1.02")	51.82 (2.04")	11X	7X	12X	5X	1.5/06/670
EAN-13 + 5	0.264 (0.0104")	0.33 (0.013")	0.66 (0.026")	20.73 (0.82")	25.91 (1.02")	51.82 (2.04")	11X	7X	12X	5X	1.5/06/670
UPC-A + 2	0.264 (0.0104")	0.33 (0.013")	0.66 (0.026")	20.73 (0.82")	25.91 (1.02")	51.82 (2.04")	9X	9X	12X	5X	1.5/06/670
UPC-A + 5	0.264 (0.0104")	0.33 (0.013")	0.66 (0.026")	20.73 (0.82")	25.91 (1.02")	51.82 (2.04")	9X	9X	12X	5X	1.5/06/670
UPC-E + 2	0.264 (0.0104")	0.33 (0.013")	0.66 (0.026")	20.73 (0.82")	25.91 (1.02")	51.82 (2.04")	9X	7X	12X	5X	1.5/06/670
UPC-E + 5	0.264 (0.0104")	0.33 (0.013")	0.66 (0.026")	20.73 (0.82")	25.91 (1.02")	51.82 (2.04")	9X	7X	12X	5X	1.5/06/670

**Note:** See Section [5.5.2.6](#) to ensure the correct Symbol Specification Table is used.

\* Special considerations exist for North American retail Point-of-Sale (POS) until a migration to international standards is completed. Until January 1, 2005, only UPC-A or UPC-E Symbols were acceptable in North America. After that date, EAN-8 and EAN-13 Symbols have also been accepted using the size specifications in Figure 5.5.2.7 – 2.

\*\* These bar code symbols may only be printed using an X-dimension below 0.264 millimetre (0.0104 inch) or 80 percent magnification under the following conditions:

- The allowance for X-dimensions between 0.2475 millimetre (0.00975 inch) or 75 percent magnification and 0.264 millimetre (0.014 inch) or 80 percent magnification is only applicable to on demand (e.g., thermal, laser) print processes. For all other printing processes, an X-dimension of 0.264 millimetre (0.0104 inch) is attainable and is the minimum allowable size.
- When printing a minimum symbol with any method of printing, the area provided for printing the symbol and the required Quiet Zone should never be less than the area required for an X-dimension of 0.264 millimetre (0.0104 inch).
- When printing a minimum symbol with any method of printing, the symbol height should never be truncated below the minimum 20.73 millimetres (0.82 inch).

\*\*\* The minimum symbol height dimensions listed for EAN/UPC Symbols include the Human Readable Interpretation. Because of the operative scanning environment for EAN/UPC Symbols, there is a direct relationship between the symbol's height and width. This means the minimum symbol height listed is tied to the minimum, target, and maximum X-dimension listed. There is no maximum for the height, but if the maximum X-dimension is used, the symbol height must be equal to or greater than those listed in the Minimum Symbol Height column.

**Figure 5.5.2.7 - 3 GS1 System Symbol Specification Table 2**

Symbol(s) Specified	*X-Dimension mm (inches)			** Minimum Symbol Height for Given X mm (inches)			Quiet Zone		***Minimum Quality Specification
	Minimum	Target	Maximum	For Minimum X-dimension	For Target X-dimension	For Maximum X-dimension	Left	Right	
EAN-13	0.495 (0.0195")	0.66 (0.026")	0.66 (0.026")	38.87 (1.53")	51.82 (2.04")	51.82 (2.04")	11X	7X	1.5/06/670
EAN-8	0.495 (0.0195")	0.66 (0.026")	0.66 (0.026")	31.94 (1.26")	42.58 (1.68")	42.58 (1.68")	7X	7X	1.5/06/670
UPC-A	0.495 (0.0195")	0.66 (0.026")	0.66 (0.026")	38.87 (1.53")	51.82 (2.04")	51.82 (2.04")	9X	9X	1.5/06/670
UPC-E	0.495 (0.0195")	0.66 (0.026")	0.66 (0.026")	38.87 (1.53")	51.82 (2.04")	51.82 (2.04")	9X	7X	1.5/06/670
ITF-14	0.495 (0.0195")	0.495 (0.0195")	1.016 (0.040")	32.00 (1.25")	32.00 (1.25")	32.00 (1.25")	10X	10X	1.5/10/670
GS1-128	0.495 (0.0195")	0.495 (0.0195")	1.016 (0.040")	32.00 (1.25")	32.00 (1.25")	32.00 (1.25")	10X	10X	1.5/10/670

**Note:** See Section [5.5.2.6](#) to ensure the correct Symbol Specification Table is used.

\* UPC-E and EAN-8 Symbols are designed for use on small packages. Whenever space permits, UPC-A, EAN-13, ITF-14, or GS1-128 Symbols should be used in the General Distribution Scanning environment.

The minimum symbol height dimensions listed for EAN/UPC Symbols include the Human Readable Interpretation. Because of the operative scanning environment for EAN/UPC Symbols, there is a direct relationship between the symbol's height and width. This means the minimum symbol height is tied to the minimum, target, and maximum X-dimension listed.

ITF-14 Symbols with X-dimensions below 0.635 millimetre (0.025 inch) should not be printed directly on corrugate with conventional (plate-based) processes. Packages and/or containers marked with ITF-14 Symbols with X-dimensions between 1.016 millimetres (0.040 inch) and 1.219 millimetres (0.048 inch) are acceptable based on historical specifications, but a migration to the 1.016 millimetres (0.040 inch) maximum X-dimension should be made on new artwork. The ITF-14 Symbol's bar width ratio target is 2.5:1, and the acceptable range is 2.25:1 to 3:1.

GS1-128 Symbols have a maximum symbol length of 165 millimetres (6.5 inch), which may impact the maximum achievable X-dimension. For example, a GS1-128 Symbol containing an SSCC has a maximum achievable X-dimension for 0.94 millimetre (0.037 inch)

\*\* The minimum symbol height for General Distribution Scanning is always 32 millimetres (1.25 inch). The minimum symbol height dimensions for ITF-14 and GS1-128 Symbols relate to the bar heights only (do not include Human Readable Interpretation text or ITF-14 Symbol Bearer Bars). There is no maximum for the height, but if the maximum X-dimension is used, the symbol height must be equal to or greater than those listed in the Minimum Symbol Height column.

\*\*\* For ITF-14 Symbols printed on labels with off-set, thermal, or laser print with an X-dimension 0.495 millimetre (0.0195 inch), the minimum quality specification is 1.5/10/670. For ITF-14 Symbols printed directly on corrugate or labels with an X-dimension greater than or equal to 0.635 millimetre (0.025 inch), the minimum quality specification is 0.5/20/670.

**Figure 5.5.2.7 - 4 GS1 System Symbol Specification Table 3**

Symbol(s) Specified	*X-Dimension mm (inches)			** Minimum Symbol Height for Given X mm (inches)			Quiet Zone		Minimum Quality Specification
	Minimum	Target	Maximum	For Minimum X-dimension	For Target X-dimension	For Maximum X-dimension	Left	Right	
EAN-13	0.495 (0.0195")	0.66 (0.026")	0.66 (0.026")	38.87 (1.53")	51.82 (2.04")	51.82 (2.04")	11X	7X	1.5/06/670
EAN-8	0.495 (0.0195")	0.66 (0.026")	0.66 (0.026")	31.94 (1.26")	42.58 (1.68")	42.58 (1.68")	7X	7X	1.5/06/670
UPC-A	0.495 (0.0195")	0.66 (0.026")	0.66 (0.026")	38.87 (1.53")	51.82 (2.04")	51.82 (2.04")	9X	9X	1.5/06/670
UPC-E	0.495 (0.0195")	0.66 (0.026")	0.66 (0.026")	38.87 (1.53")	51.82 (2.04")	51.82 (2.04")	9X	7X	1.5/06/670



**Note:** See Section [5.5.2.6](#) to ensure the correct Symbol Specification Table is used.

\* Special considerations exist for North American retail POS until a migration to international standards is completed. Until January 1, 2005, only UPC-A or UPC-E Symbols were acceptable in North America. After that date, EAN-8 and EAN-13 Symbols have been accepted using the size specifications in Figure 5.5.2.7 - 4.

UPC-E and EAN-8 Symbols are designed for use on small packages. Whenever space permits, UPC-A and EAN-13 Symbols should be used.

\*\* The minimum symbol height dimensions listed for EAN/UPC Symbols include the Human Readable Interpretation. Because of the operative scanning environment for EAN/UPC Symbols, there is a direct relationship between the symbol's height and width. This means the minimum symbol height listed is tied to the minimum, target, and maximum X-dimension listed.

There is no maximum for the height, but if the maximum X-dimension is used, the symbol height must be equal to or greater than those listed in the Minimum Symbol Height column.

**Figure 5.5.2.7 - 5 GS1 System Symbol Specification Table 4**

Symbol(s) Specified	*X-Dimension mm (inches)			** Minimum Symbol Height for Given X mm (inches)			Quiet Zone		Minimum Quality Specification
	Minimum	Target	Maximum	For Minimum X-dimension	For Target X-dimension	For Maximum X-dimension	Left	Right	
EAN-13	0.264 (0.0104")	0.33 (0.013")	0.66 (0.026")	20.73 (0.82")	25.91 (1.02")	51.82 (2.04")	11X	7X	1.5/06/670
EAN-8	0.264 (0.0104")	0.33 (0.013")	0.66 (0.026")	17.03 (0.67")	21.29 (0.84")	42.58 (1.68")	7X	7X	1.5/06/670
UPC-A	0.264 (0.0104")	0.33 (0.013")	0.66 (0.026")	20.73 (0.82")	25.91 (1.02")	51.82 (2.04")	9X	9X	1.5/06/670
UPC-E	0.264 (0.0104")	0.33 (0.013")	0.66 (0.026")	20.73 (0.82")	25.91 (1.02")	51.82 (2.04")	9X	7X	1.5/06/670
ITF-14	0.250 (0.00984")	0.495 (0.0195")	0.495 (0.0195")	12.70 (0.50")	12.70 (0.50")	12.70 (0.50")	10X	10X	1.5/10/670
GS1- 128	0.250 (0.00984")	0.495 (0.0195")	0.495 (0.0195")	12.70 (0.50")	12.70 (0.50")	12.70 (0.50")	10X	10X	1.5/10/670



**Note:** See Section [5.5.2.6](#) to ensure the correct Symbol Specification Table is used.

- \* ITF-14 Symbols with X-dimensions below 0.635 millimetre (0.025 inch) should not be printed directly on corrugate with conventional (plate based) processes. Packages and/or containers marked with ITF-14 Symbols with X-dimensions between 1.016 millimetres (0.040 inch) and 1.219 millimetres (0.048 inch) are acceptable based on historical specifications, but a migration to the 1.016 millimetre (0.040 inch) maximum X-dimension should be made on new artwork. The ITF-14 Symbol's bar width ratio target is 2.5:1, and the acceptable range is 2.25:1 to 3:1.

Appendix 5.5.3.4 gives full details on when bar code symbols can be printed at less than the minimum X-dimension. In general, bar code symbols may only be printed using an X-dimension below 0.264 millimeter (0.0104 inch) or 80 percent magnification under the following conditions:

- The allowance for X-dimensions between 0.2475 millimetre (0.00975 inch) or 75 percent magnification and 0.264 millimetre (0.014 inch) or 80 percent magnification is only applicable to on demand (e.g., thermal, laser) print processes. For all other printing processes, an X-dimension of 0.264 millimetre (0.0104 inch) is attainable and is the minimum allowable size.
- When printing a minimum symbol with any method of printing, the area provided for printing the symbol and the required Quiet Zone should never be less than the area required for an X-dimension of 0.264 millimetre (0.0104 inch).
- When printing a minimum symbol with any method of printing, the symbol height should never be truncated below the minimum 20.73 millimetres (0.82 inch).

- \*\* The minimum symbol height dimensions listed for EAN/UPC Symbols include the Human Readable Interpretation, but the minimum symbol height dimensions for ITF-14 and GS1-128 Symbols relate to the bar heights only (do not include Human Readable Interpretation text or ITF-14 Bearer Bars).

Because of the operative scanning environment for EAN/UPC Symbols, there is a direct relationship between the symbol's height and width. This means the minimum symbol height listed is tied to the minimum, target, and maximum X-dimension listed.

The minimum bar height for ITF-14 and GS1-128 Symbols in this operative scanning environment is 12.7 millimetres (0.50 inch), but if the package is physically too small to accommodate this rule, further truncation is permitted. In no case shall the bar height be less than 5.08 millimetres (0.20 inch).

There is no maximum for the symbol height, but if the maximum X-dimension is used, the symbol height must be equal to or greater than those listed in the Minimum Symbol Height column.

Whereas, linear symbol heights are set at a fixed dimension, Composite Components are printed at the same density as the linear portion of the Composite Symbology, and the bar code height varies depending on the amount of data, the printing density, and which linear symbol is used in conjunction with the Composite Component. Note that Composite Components have to be printed with a linear symbol such as GS1 DataBar (formerly RSS), GS1-128, UPC-A, or EAN-13. ITF cannot be used with Composite Components.

**Figure 5.5.2.7 – 6 GS1 System Symbol Specification Table 5**

Symbol(s) Specified	*X-Dimension mm (inches)			** Minimum Symbol Height for Given X mm (inches)			Quiet Zone		Minimum Quality Specification
	Minimum	Target	Maximum	For Minimum X-dimension	For Target X-dimension	For Maximum X-dimension	Left	Right	
GS1-128	0.495 (0.0195")	0.495 (0.0195")	0.940 (0.037")	32.00 (1.25")	32.00 (1.25")	32.00 (1.25")	10X	10X	1.5/10/670



**Note:** See Section [5.5.2.6](#) to ensure the correct Symbol Specification Table is used.

- \* If the item is too small to accommodate the minimum X-dimension, the minimum X-dimension is 0.250 millimetre (0.00984 inch).
- \*\* The minimum symbol height indicated is for bar height only and does not include the Human Readable Interpretation. If the item is too small to accommodate the minimum, the minimum bar height is the greater of 15 percent of the symbol width including Quiet Zones or 12.7 millimetres (0.50 inch). If the package is physically too small to accommodate this rule, further truncation is permitted, but in no case shall the bar height be less than 5.08 millimetres (0.20 inch).

There is no maximum for the height, but if the maximum X-dimension is used, the symbol height must be equal to or greater than those listed in the Minimum Symbol Height column.

**Figure 5.5.2.7 - 7  
GS1 System Symbol Specification Table 6 - 2D Symbols Using Composite Component (CC)**

Symbol(s) Specified	X-Dimension mm (inches)			Minimum Symbol Height for Given X mm (inches)			Quiet Zone		Minimum Quality Specification
	Minimum	Target	Maximum	Minimum	Target	Maximum	Left	Right	
CC-A	Consult Table 4, since all CCs need to be printed at the same printing densities as their linear components			Height is determined by X-Dimension for data that is encoded			1X	1X	1.5/06/670
CC-B				Height is determined by X-Dimension for data that is encoded			1X	1X	1.5/06/670
CC-C				Height is determined by X-Dimension for data that is encoded			2X	2X	1.5/06/670

**Figure 5.5.2.7 - 8 GS1 System Symbol Specification Table 7 - Very Small Healthcare Items and Direct Part Marking**

Symbol(s) Specified	**X-Dimension mm (inches)			Minimum Symbol Height for Given X mm (inches)			*Quiet Zone		Minimum Quality Specification
	Minimum	Target	Maximum	For Minimum X-dimension	For Target X-dimension	For Maximum X-dimension	Left	Right	
GS1 DataBar Stacked	0.170 (0.0067")	0.20 (0.008")	0.41 (0.016")	2.21 (0.087")	2.64 (0.104")	5.28 (0.208")	Not Applicable		1.5/06/670
GS1 DataBar Limited	0.170 (0.0067")	0.20 (0.008")	0.41 (0.016")	1.70 (0.067")	2.03 (0.080")	4.07 (0.160")	Not Applicable		1.5/06/670
GS1 DataBar Stacked Omnidirectional	0.170 (0.0067")	0.20 (0.008")	0.41 (0.016")	11.73 (0.4623")	13.8 (0.552")	28.51 (1.104")	Not Applicable		1.5/06/670
GS1 DataMatrix	0.255 (0.01005")	0.3 (0.012")	0.615 (0.024")	Height is determined by X-Dimension for data that is encoded			1X	1X	1.5/06/670
Direct Part Marking	**** 0.380 (0.0150")	0.380 (0.0150")	0.495 (0.0195")	Height is determined by X-Dimension for data that is encoded			1X	1X	1.5/****/670

- \* Quiet Zones for GS1 DataMatrix are 1X on all four sides.
- \*\* Because of the physics of optics, GS1 DataMatrix needs to be printed at 1.5 times the equivalent printing density allowed for linear or Composite Symbols.
- \*\*\* The effective aperture for GS1 DataMatrix quality measurements should be taken at 80 percent of the printing density. For Direct Part Marking this would equate to an aperture of 12; for healthcare printing, an aperture of 8.
- \*\*\*\* Minimum has been set close to target value until specifications and testing can justify changing this to a lower value.

### 5.5.3. Bar Code Production

The following subsections will:

- Provide background on major bar code printing methods and materials
- Provide general printing and packaging background for major application groups

The various definitions and specialist terms used throughout this section can be found in *ISO/IEC 15419*, Information Technology, Automatic Identification and Data Capture Techniques, Bar Code Digital Imaging and Printing Performance Testing.

#### 5.5.3.1. Digital Imaging

##### 5.5.3.1.1. General Requirements

General requirements consisting of the following topics can be found in Section 4 of *ISO/IEC 15419*.

- Data input
- Quiet Zones
- Classification of imaging device categories, from informative reference Annex E of *ISO/IEC 15419*
- Programmer's examples, from informative reference Annex F of *ISO/IEC 15419*
- Programmer's example for general-purpose printers

- Programmer's example for indirect bar code imaging devices
- Programmer's example for symbols distorted for plate roll circumference
- Direct bar code imaging devices
- Dedicated bar code printers
- Adjustment of target element dimensions
- Record of design elements
- General purpose printers
- Adjusted bar width compensation (BWC) (including the General Purpose Printer Dot/Pixel Comparison figure)
- Record of design attributes
- Indirect bar code imaging devices
- Adjustments for planned distortion (disproportioning)
- Adjustments for special EAN/UPC Symbol characters
- Test requirements
  - System configuration
  - Test procedure
- Conformance
- Test report, including sample test layout, from normative reference Annex A of *ISO/IEC 15419*
- Certification
- Software specification, including classification of software categories, from informative reference Annex D of *ISO/IEC 15419* and functions of bar code production software from informative reference Annex G of *ISO/IEC 15419*
- Maintenance and supplies, from informative reference Annex C of *ISO/IEC 15419*

#### 5.5.3.1.2. Dedicated Bar Code Printers

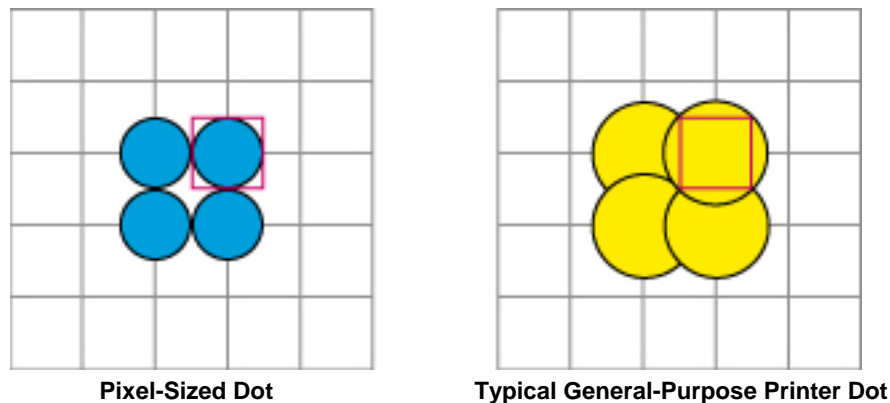
Section 5 of *ISO/IEC 15419* contains information on dedicated bar code symbol printers and includes the following topics:

- Data input requirements
- Test requirements
- Selection of equipment for testing
- Test conditions; environment, equipment configuration
- Test procedure
- Conformance
- Test report
- Certification and labelling
- Equipment specification

### 5.5.3.1.3. EAN/UPC On-Demand Printed Symbols at Minimum Size

It is more difficult for the user to create high quality bar code symbols with general-purpose printers than it is with direct thermal transfer label printers. There are two reasons for this difficulty. First, the printed dot size for general-purpose printers is appreciably larger than the pixel dimension, as shown in Figure 5.5.3.1.3 - 1. This causes the bars (dark bars) to be printed wider and the spaces (light bars) to be narrower than nominal, unless the software driving the printer corrects for this distortion. Second, the software that constructs the bar code may itself introduce dimensional errors.

Figure 5.5.3.1.3 - 1 Example of Digital Printing



The most common printing densities used by on-demand, bar code symbol printers are 200 and 300 dpi. However, due to the constraints of the dot pitch, these printers cannot print a minimum X-dimension of 0.264 (0.0104 inch) or 80 percent magnification symbol correctly. The closest to 80 percent that these printers can print is 75.7 percent or 76.9 percent depending on the exact dot geometry (see Figure 5.5.3.1.3 - 2).

Even though a minimum X-dimension of 0.264 (0.0104 inch or 80 percent magnification) is the minimum value specified, users of on-demand printers have used magnifications between 75 percent and 80 percent in Point-of-Sale (POS) scanning environments for years. They have done so with no significant reduction in scan rate, as compared to symbols printed precisely at 80 percent. Because larger in-specification symbols are always easier to scan, 80 percent symbols and larger are preferred. However, when an on-demand printer is required, the 75 to 80 percent symbols are an acceptable alternative given the following qualifications for printing:

- The allowance for symbols from the EAN/UPC Symbology family of magnifications from 75 to 80 percent is only applicable to on-demand (e.g., thermal, laser) print processes. For all other printing processes, 80 percent is attainable and is the minimum allowable size.
- When printing a minimum symbol with any method of printing, the area provided for printing the symbol, including the required Quiet Zones, should never be less than the area required for an 80 percent symbol. This area can be derived from the total width of an 80 percent symbol times its height.
- When printing a minimum symbol with any method of printing, the symbol height should never be truncated below the 80 percent value (20.7 millimetres or 0.816 inch).
- The minimum print quality grade is the same for all symbols in the EAN/UPC Symbology family: 1.5/06/670.

**Figure 5.5.3.1.3 - 2 Achievable X-Dimensions for Thermal Printed EAN/UPC Symbols**

Reference DPI	Actual DPI	Dots Per Millimetre	Actual Dot Width (Centre Point to Centre Point)		Dots Per Module Width	Module Width (X-Dimension)		*Corrected Magnification
			Inch	mm		Mils	mm	
200	203.2	8	0.004921	0.12500	2	9.843	0.25000	**75.76%
200	203.2	8	0.004921	0.12500	3	14.764	0.37500	113.64%
200	203.2	8	0.004921	0.12500	4	19.685	0.50000	151.52%
200	203.2	8	0.004921	0.12500	5	24.606	0.62500	189.39%
300	304.8	12	0.003281	0.08333	3	9.843	0.25000	**75.76%
300	304.8	12	0.003281	0.08333	4	13.123	0.33333	100.01%
300	304.8	12	0.003281	0.08333	5	16.404	0.41667	126.26%
300	304.8	12	0.003281	0.08333	6	19.685	0.50000	151.52%
300	304.8	12	0.003281	0.08333	7	22.966	0.58333	176.77%
400	406.4	16	0.002461	0.06250	4	9.843	0.25000	**75.76%
400	406.4	16	0.002461	0.06250	5	12.303	0.31250	94.70%
400	406.4	16	0.002461	0.06250	6	14.764	0.37500	113.64%
400	406.4	16	0.002461	0.06250	7	17.224	0.43750	132.58%
400	406.4	16	0.002461	0.06250	8	19.685	0.50000	151.52%
400	406.4	16	0.002461	0.06250	9	22.146	0.56250	170.45%
400	406.4	16	0.002461	0.06250	10	24.606	0.62500	189.39%
600	609.6	24	0.001640	0.04167	6	9.843	0.25000	**75.76%
600	609.6	24	0.001640	0.04167	7	11.483	0.29167	88.38%
600	609.6	24	0.001640	0.04167	8	13.123	0.33333	101.01%
600	609.6	24	0.001640	0.04167	9	14.764	0.37500	113.64%
600	609.6	24	0.001640	0.04167	10	16.404	0.41667	126.26%
600	609.6	24	0.001640	0.04167	11	18.045	0.45833	138.89%
600	609.6	24	0.001640	0.04167	12	19.685	0.50000	151.52%
600	609.6	24	0.001640	0.04167	13	21.325	0.54167	164.14%
600	609.6	24	0.001640	0.04167	14	22.966	0.58333	176.77%
600	609.6	24	0.001640	0.04167	15	24.606	0.62500	189.39%

\* The nominal EAN/UPC Symbol can be based on a module width (X-dimension) of either 0.013 inch or 0.33 millimetre. In North America, long-standing GS1 US specifications set the nominal module size (X-dimension) at 0.013 inch or 13 millimetres. The ISO/IEC specification for EAN/UPC Symbols set the nominal module size (X-dimension) at 0.33 millimetre. The international metric nominal is 0.0606 percent smaller than the original inch-based nominal. The data in the right-most column labelled "Corrected Magnification" are based on a nominal module width (X-dimension) of 0.33 millimetre.

\*\* See Figure 5.5.2.7 – 2 for when a Magnification of less than 80% is acceptable

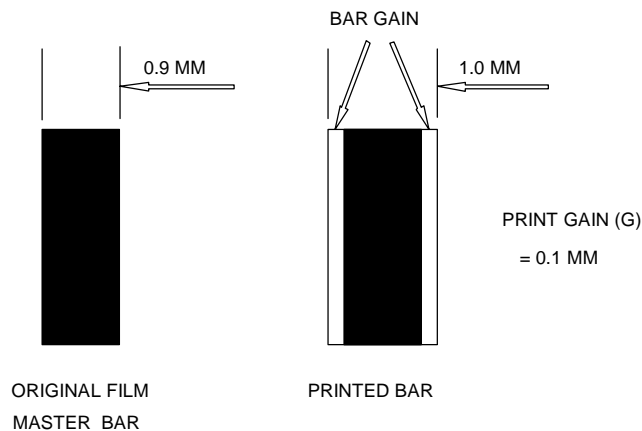
### 5.5.3.2. Film Master Production

#### 5.5.3.2.1. Introduction

For symbols in the EAN/UPC Symbology family, the biggest usage of verification has always been in conjunction with printing and production of packaging and labels by means of the conventional or "wet ink" printing processes, such as offset lithography, flexography, and photogravure. These printing processes use a Film Master as the initial artwork of the symbol, although some form of electronic origination of the symbol is increasingly replacing this high-precision article.

The first point at which one might use verification is the printability test stage prior to actual production of "real-life" symbols, where a printing run of a test symbol is carried out under normal conditions and measured in order to characterise the printing process for a particular press and printing substrate. It is necessary to assess how much bar gain (or loss) has occurred and over what range of variation, to decide how much bar width adjustment (BWA) is required. BWA can be in the form of bar width reduction (BWR), where there is print gain, or the less common bar width increase (BWI). The required BWA is associated with the X-dimension used. These details are required in order to specify the Film Master correctly, or as input parameters for the bar code symbol origination software.

**Figure 5.5.3.2.1 - 1 Example of Bar Width Adjustment**



Verifying the Film Master on receipt confirms that the correct BWA has been applied and that it is otherwise as specified. Note that a special type of verifier using traditional measurement and capable of more precise measurement is necessary at this point, since Film Master requirements are specified in terms of element widths and are subject to tolerances of only plus or minus five microns for EAN/UPC Symbols. In addition, the verifier needs to be capable of measuring the intensity of light transmitted through, rather than that reflected by, the film material. Also, Film Masters may be either photographic positives or negatives, and in the latter case, the light and dark characteristics of the background and bars are reversed. In the absence of such a verifier, reliance may be placed on the verification report normally provided by the Film Master supplier with the master.

If a proof of the print job is produced, the bar code symbol should be verified as part of the approval process. Note, however, that since proofing presses are not the same as production printing presses, there may be a slight difference in the quality of the proof and the production job.

While the presses are being made ready, a check of bar widths on the first few printed sheets can help to ensure that the press is correctly set to produce near-ideal bar widths. Once the presses have started to roll, periodic sampling should be carried out, at intervals based on experience or dictated by the company's quality control procedures, to monitor both bar widths and other aspects of symbol quality (in particular Symbol Contrast), since these are the attributes most easily adjusted during the run.

Finally, a further sample should be verified following completion of the print job. The Scan Reflectance Profile (SRP) analysis should be used as the basis for decision making, to ensure that the job has achieved at least the minimum quality grade specified by the customer or based on the application.

The following items are recommended to appear on or with a Film Master:

- X-dimension (magnification factor)
- Selected bar (line) width reduction
- Product identification, including company name
- A test square (outside the symbol area) for emulsion studies (this should be incorporated in the film, not affixed on a separate label)
- Printing process for which the Film Master is intended
- Identification of the Film Master supplier
- Date of Film Master manufacture

#### 5.5.3.2.2. Terms and Definitions

Definitions for the following terms can be found in *ISO/IEC 15421*, Section 4:

- Achieved bar width difference
- Bar edge
- Bar edge conformance
- Bar edge contour
- Bar edge gradient
- Bar width adjustment (BWA)
- Bar width increase (BWI)
- Bar width reduction (BWR)
- Bar width tolerance
- Base density
- Negative image
- Nominal bar width (EAN/UPC Family)
- Optical density profile
- Polarity
- Positive image
- Specified bar width
- Target element width

#### 5.5.3.2.3. Physical Requirements

Physical requirements consisting of the following topics can be found in Section 6 of *ISO/IEC 15421* Information Technology, Automatic Identification and Data Capture Techniques, Bar Code Master Test Specifications:

- Material
  - Dimensional stability

- Archival properties
- Physical requirements controlled by the manufacturing process
  - Target bar width
  - Bar width adjustment (BWA)
- Tolerances
  - Tolerance A – all symbologies
  - Tolerance B – two-width symbologies
  - Tolerance C – (n,k) symbologies
  - Tolerance D – all symbologies
- Bar edge characteristics
  - Bar edge conformance
  - Bar edge gradient
- Defects
- Quiet Zones
- Corner marks
- Optical densities (including table “Reference Density Values,” and, from informative reference Annex A of *ISO/IEC 15421* Optical Density Profiles, the following figures: Minimum and Maximum Values of Optical Density, Measurement of Slope, Threshold Point for Bar Edge Determination, Measurements for Ratio-Based Symbologies, Measurements for (n,k) Symbologies, and Symbol Character Pitch Measurement)
  - Minimum density ( $D_{\min}$ )
  - Maximum density ( $D_{\max}$ )
- Orientation
- Polarity
- Encodation
- Human Readable Interpretation
- Test Methods
  - Bar and space width measurement
  - Conditions for dimensional measurements
  - Calculation of the achieved BWA
  - Test report and traceability

### 5.5.3.3. Quality Assessment

#### 5.5.3.3.1. Verification

Verification is the technical process by which a bar code symbol is measured to determine its conformance with the specification for that symbol. Verification is not intended to be used alone as a method for downstream rejection. For example, GS1's advice is to use the *ISO/IEC 15416* methodology as a tool to improve overall scanning performance. For problem GS1 System symbols,

an ISO-based verifier can be of enormous assistance in diagnosing the problem and providing a standard means of reporting among printing companies and their trading partners.

It is also important to note the difference between a scanner and a verifier. A verifier is a measuring tool by which one can make certain determinations concerning the ability of the symbol to do its job, namely, to carry and deliver data on demand. Because traditional verification measurement is typically made in a single scan across the symbol, it is uncertain whether this "snapshot" is truly representative of the symbol's characteristics through the height of the bars.

When interpreting the results from verification it is also important to remember that:

- Most verifiers do not measure bar height.
- Without additional software linking the decoded data to a database, the quality and accuracy of the data content of a symbol cannot be confirmed.
- The verifier cannot confirm that the symbol dimensions are those intended and are as indicated in Symbol Specification Tables (SSTs). For example, many of the simpler verifiers cannot measure in dimensional terms (X-dimension), though they can be remarkably accurate in measuring the relationships of element widths to each other. The amount that bar widths differ from nominal width on average in a symbol is called the average bar error. This number is expressed as a fraction of X-dimension. A positive value indicates average bar growth and a negative value indicates bar shrinkage.
- The verifier does not check that the Human Readable Interpretation matches the bar code data (and it may be necessary to check that the two correspond, particularly where the bar code generating software does not include Human Readable Interpretation data).
- Because only a sample of the symbols produced are actually verified, the quality of all the symbols in a production batch cannot be guaranteed beyond the statistical confidence limits associated with the sampling rate used.
- Even a perfect symbol at the time of production can be damaged or otherwise affected in its passage through the supply chain (e.g., scratched, frozen, dampened).
- Operator error can cause inconsistent results. Operators should be properly trained and visual checks should be made to confirm verifier results (e.g., where the bar code is expected to get a good result and fails the verifier test, recheck the operation of using the verifier).
- The correct bar code symbol has been printed for the scanning environment of the item (e.g., an ITF-14 Symbol used on an item intended for retail Point-of-Sale).

#### 5.5.3.3.1.1. Traditional Verification

Traditional verification methods were introduced in the early to mid-1970s and were based on the measurement of two symbol parameters: print contrast signal (PCS) and the bar width deviation. If the bar (or space) widths were within a defined (but somewhat arbitrary) tolerance, and if PCS was above a defined minimum value, the symbol was regarded as being "in spec."

Initially, none of these measurements were automated, and human factors affected the accuracy and consistency of measurements. Also, checking that the symbol was correctly encoded was a laborious task. However, within a few years, instruments were developed that performed these measurements automatically. These were the first true verifiers that enabled the printer to take steps to produce the symbols as nearly perfectly as this process allowed.

Traditional verification does not necessarily give results that correlate very closely with the actual scanning performance of the symbols. One reason is that the assessment of the symbol gives only a single threshold for acceptability: "Pass" or "Fail." In addition if the assessment is based on a single scan across the symbol, which might be through an exceptionally good or bad section of the symbol, it cannot be guaranteed to be truly representative of its condition.

Measurements of bar gain or loss are less meaningful in the case of certain symbologies, like the EAN/UPC Symbology and the GS1 128 Bar Code Symbol, where decoding relies primarily on edge-to-similar-edge distances, which are relatively immune to even substantial amounts of consistent gain or loss across the symbol. These distances are measured from the leading edge of one bar to the leading edge of the next (or from one trailing edge to the next), which tends to move in the same direction if there is bar gain or loss. A more subtle factor is that the method is not standardised, either as to where the dark and light reflectance (or density) measurements are made for the calculation of PCS, or as to how the exact position of an element edge is defined, so that some models of verifier could assess a given symbol as "Pass" whereas others could "Fail" it – a source of potential and, indeed, actual disagreements among suppliers and customers.

#### 5.5.3.3.1.2. ISO Verification

During the 1980s, two factors led to attempts to improve the traditional verification technique. One was the disparity between traditional verification results and the real life performance of symbols, and the other was the increasing number of product rejections by customers based on differing verification results between the supplier's instrument and his customer's.

A wide-ranging programme by a group of experts from bar code and user industries working on all types of scanning systems determined the factors that most directly affect symbol-scanning performance and resulted in the analysis of the Scan Reflectance Profile (SRP). This methodology was originally known as ANSI verification because it was first described in the United States' standard ANSI X3.182, published in 1990 under the title *Bar Code Print Quality Guidelines*. The method was then defined in a European standard (*EN 1635*), published in 1995, and an international standard (*ISO/IEC 15416*), published in 2000. *ISO/IEC 15416* is the definitive international specification of the ISO bar code verification methodology, and the numeric grading system is used.

The method, as described in the *ISO/IEC 15416* standard, is technically fully compatible with the ANSI X3.182 and *EN 1635* method, so verifiers based on these standards are not obsolete.

In simple terms, an ISO verifier looks at the symbol in exactly the same way a scanner sees it. The ISO verifier reports its assessment of the symbol quality not as a single "Pass" or "Fail" decision, but as one of a range of four passing grades (from 4 to 1, in order of decreasing quality) or one failing grade (0). This enables an application to set the most appropriate minimum grade for acceptability. It may be noted that the ANSI standard uses the alphabetic scale A to D for passing grades and F for failing symbols, but the grade thresholds are identical.

The relationship between symbol grades measured in this way and the way the symbols behaved when they were scanned was so close that users rapidly came to accept the SRP assessment method for verifying symbols received from their trading partners. Users knew that as long as a symbol achieved grade 1.5 or better it would give them acceptable performance when they had to scan it to capture the encoded data.



**Note:** The GS1 System requires that the Quiet Zone be a measured parameter for EAN/UPC Symbology, GS1-128 Symbols, and ITF-14 Symbols per the values expressed in *ISO/IEC 15416*, Section 5.

#### 5.5.3.3.1.3. Types of Verifiers

There are many types of verifiers and almost as many ways of classifying them, but for practical purposes, it is convenient to group them into two classes related to where they are used and the extent to which all their possible functions are required. This grouping corresponds reasonably closely to the Class A and Class B classification respectively (as used in the European pre-standard ENV 12647).

The first group (broadly equivalent to the Class A category) contains the full-function type of verifier, which is mainly found in a quality control laboratory. It performs a full range of measuring functions and provides comprehensive analytical reports on the symbol, enabling the cause of problems to be

diagnosed. Its use requires a good degree of knowledge of the technology, and the operator must, therefore, be specially trained. Its measurement accuracy may be substantially higher than the average; its cost almost certainly is, and the time taken to perform the necessary scans and output the results may be relatively long; however, in the expected conditions for which such an instrument is purchased, this is not likely to be a problem. This type of verifier may have motorised optical heads to improve the evenness of movement and achieve the multiple scanning requirements, and to enable accurate dimensional measurements. In addition, this verifier may have interchangeable measuring apertures and light sources to enable measurement of symbols with a wide range of X-dimensions and to meet the illumination needs of differing application standards. Some of these instruments are used in conjunction with a personal computer with special verification software for the symbol analysis and display/printing of results, while others are integrated stand-alone units.

The second group (corresponding to the Class B category) contains all the simpler, easy-to-use devices intended for use in the pressroom or on the receiving dock by relatively less trained operators. At their simplest, these devices are used to rapidly check that symbols are of the desired grade or better and, particularly in the pressroom, to obtain an indication of bar gain or loss and of contrast to help the press operator fine-tune his machine. Typically they have a single light source and measuring aperture, though by using plug-in wands or mice, a degree of interchange functionality may be achieved. Some instruments use laser beam illumination, which facilitates multiple scans of the symbol, though the effective measuring aperture may not be circular in shape, and its size may not be precisely known. They also may be more limited in their reflectance measurements.

A group of specialised verifiers is designed for mounting on printing equipment. They monitor the bar code symbols produced by the equipment and provide continuous analysis of key parameters, notably element widths, to enable the operator to control the printing process very quickly. Some are designed for high-speed presses and others for on-demand printers. Some are even able to automatically feed back control instructions to improve symbol quality and reprint defective labels.

A particular verifier may be hard to fit neatly into either class, as it may resemble the simpler class of unit in its physical construction, but its functions and the amount of information that it can give on the symbol may correspond more closely to those of the laboratory unit. Partly for this reason and partly because the Class A and Class B reporting requirements did not necessarily correspond precisely to what a verifier manufacturer might wish to offer for commercial reasons, the international standard *ISO/IEC 15426-1*, which replaces *ENV 12647*, has eliminated the classification scheme in favour of a minimum set of reporting requirements for all verifiers, to which manufacturers are at liberty to add in accordance with their view of the market needs.

#### 5.5.3.3.2. Measurement Methodology

The symbol should be verified in its final configuration wherever possible (e.g., including over-laminate, package material, contents), but if this is not feasible, the following procedure is recommended to allow for the effects of show-through.

Place the symbol to be verified on a flat surface. If the substrate is not opaque (allows light through), perform the verification procedure with the symbol on a dark surface, and then repeat it on a light surface. Take the poorer set of results, unless it is known what type of material is likely to back the symbol in practice, in which case attempt to match it.

#### 5.5.3.3.3. Symbol Grading

Symbol Grading consisting of the following topics can be found in Section 6 of *ISO/IEC 15416*:

- Scan Reflectance Profile (SRP) grading (further explained in normative reference Annex B of *ISO/IEC 15416*)
- Decode
- Reflectance parameter grading (including the Reflectance Parameter Grading figure)

- Decodability (including the Decodability Grades figure; also covered in normative reference Annex A of *ISO/IEC 15416*)
- Expression of symbol grade
- Symbol grading process flowchart is available from normative reference Annex C of *ISO/IEC 15416*
- Example of verification report is available from informative reference Annex H of *ISO/IEC 15416*

#### 5.5.3.3.4. Substrate Characteristics

Substrate characteristics consisting of the following topics can be found in the informative reference Annex D of *ISO/IEC 15416*

- Substrate opacity
- Gloss
- Over-laminate
- Static reflectance measurements
- Prediction of Symbol Contrast
- Prediction of minimum edge contrast ( $E_{c_{min}}$ ) and modulation (MOD)
- Acceptability of measured and derived values

#### 5.5.3.3.5. Interpretation of the Scan Reflectance Profile and Profile Grades

Interpretation of the Scan Reflectance Profile (SRP) and profile grades consisting of the following topics can be found in the informative reference Annex E of *ISO/IEC 15416*:

- Significance of SRPs
- Interpretation of results
- Matching grades to applications
- Alphabetic grading

#### 5.5.3.3.6. Comparison with Traditional Methodologies

Comparison with traditional methodologies consisting of the following topics can be found in the informative reference Annex I of *ISO/IEC 15416*:

- Traditional methodologies
- Correlation of print contrast signal with Symbol Contrast measurements
- Guidance on grading for applications also specifying print contrast signal (PCS)

#### 5.5.3.3.7. Process Control Requirements

Process control requirement methodologies consisting of the following topics can be found in the informative reference Annex J of *ISO/IEC 15416*:

- Process control for repetitive printing
- Number of scans
- Bar width deviation

- Two-width symbologies
- (n,k) symbologies
- Average bar gain/loss

Average bar error is not graded directly, but is used to calculate what fraction of a defined bar tolerance is consumed by the printing process. This traditional bar tolerance calculation differs by symbology and, in the case of the EAN/UPC Symbology, it also differs by the X-dimension at which the symbol is printed. Generally a smaller X-dimension yields a smaller tolerance.

#### 5.5.3.3.8. Compliance Statement

Verifiers that are suitable for use with the recommendations contained in these *GS1 General Specifications* will often be supplied with a statement that associates the instrument with the following calibration standards:

*“Applied Image certified EAN/UPC Symbology calibration standards are manufactured to specifications set by Applied Image and the collaboration of GS1 using ISO/IEC 15416 methodology and are calibrated using standards traceable to the National Institute of Standards and Technology.”*

#### 5.5.3.3.9. Calibrated Conformance Standard Test Cards

The verifier operator may use a variety of tools and procedures to periodically ensure maintenance of the verifier's calibration. For example, the operator may follow the manufacturer's recommended procedure for set-up, programming (if necessary), normal operational calibration, and use of the verifier prior to performing any tests. Indeed such procedures are considered essential to ensure the consistency of verification results over time.

Some verifier manufacturers may require the operator to utilise a calibration patch designed for use in maintaining instrument calibration. A common form of patch is often referred to as a "reflectance patch," which may be provided with the instrument. It is very important that the manufacturer's instructions are followed carefully and conscientiously to properly calibrate the instrument. An indication of "calibration complete" normally signals successful recalibration of the device.

Other manufacturers may require periodic factory calibration of their verifier to maintain proper calibration.

With the increasing use of verifiers as communication tools, all verifiers must be periodically checked for their calibration conformance to a traceable standard (within accuracy and repeatability limits stated by the manufacturer). For this reason, Calibrated Conformance Standard Test Cards are available for the verifier user.

Calibrated Conformance Standard Test Cards have been designed for verifiers with 6, 10, and 20 millimetre apertures, and the following are currently available from GS1:

- EAN/UPC Calibrated Conformance Standard Test Card
- ITF Calibrated Conformance Standard Test Card
- GS1-128 Calibrated Conformance Standard Test Card
- GS1 DataBar (formerly RSS) Calibrated Conformance Standard Test Card
- Use of these test cards provide a number of benefits including:
  - Validates verifiers for UPC-A, EAN-13, ITF, GS1-128, and GS1 DataBar (formerly RSS) linear symbols. Covers all GS1 symbologies except Composite Component and GS1 DataMatrix (two-dimensional bar code).
- Training tool for operators of verifiers

- Validates that the verifier is working within its specified tolerances for the symbology selected

Each test card is designed to test particular characteristics of *ISO/IEC 15416*-based verification equipment. The standards are manufactured on special materials and are made traceable to the National Institute of Standards and Technology (NIST). This traceability is facilitated through a custom designed piece of hardware (nicknamed “the Judge”) and has been engineered to measure the various attributes outlined in *ISO/IEC 15416*. The Judge has also been made traceable to NIST in Washington, D.C.

The idea behind the standard is to regularly test the verification equipment to ensure it is operating within ISO tolerance levels as published by the verifier manufacturer. This is especially important in heavy use applications where various operators may be involved or where a new user is learning to properly verify. The operator should routinely scan each of the symbols on the test card to determine if the verifier device provides the values listed. These specifications stipulate an aperture and 670 nanometres  $\pm$ 10 nanometres wavelength be used, and the exact scanning method should be determined by following all of the verifier manufacturer recommendations. This may require some practice to obtain the right touch, but it will inform the operator when the correct method has been used.

If the verifier reports values that agree with the values listed on the test card (within the verifier manufacturer’s stated accuracy and repeatability limits), then the operator can assume the verifier is calibrated. If, after repeated attempts, the device does not provide the value as printed on the standard (within the verifier manufacturer’s stated accuracy and repeatability limits), then the device or the operator’s scanning technique must be considered suspect. In this event, the operator should refer to his or her operator’s manual as to the proper remedies specified by the verifier manufacturer.

Test cards are sensitive and should be handled with care. If the symbols show dirty areas, one can safely clean these by using a soft cotton pad and photographic grade film cleaner. If visible scratches develop on a symbol, that area of the symbol should not be used. If sufficient visible scratches develop so that a clean scan path is not available, then the test card is no longer useable and should be replaced.

The test card serves as a device for, or means of, confirming that an ISO-based verifier has been properly calibrated and that users are obtaining results within the accuracy limits stated by the manufacturer of their instruments.

It is possible that a defective verifier, use of a damaged or incorrect reflectance patch, or, in some cases, a careless user performing the calibration to the patch might provide a false indication of successful calibration. The proper use of the Calibrated Conformance Standard Test Cards is the only way multiple trading partners can be assured of reliable quality measurements for the printed GS1 endorsed symbol.

As a general rule, any ISO-based verifier (NIST or non-NIST traceable) should be periodically tested using a Calibrated Conformance Standard Test Card. This procedure will confirm both the accuracy of the instrument and the skill of the user.

### 5.5.3.3.10. Special Considerations for Verification of GS1 System Symbologies

#### 5.5.3.3.10.1. General

Since ISO verification does not measure dimensions, it is part of the additional visual checking that has to be carried out to ensure that, for example, the symbol height meets the application requirements.

With better digital imaging software, element dimensions can only be adjusted automatically to the nearest integer number of pixels in the output device, be it imagesetter or printer, enabling element width ratios to be maintained with allowance duly made, for example, for print gain/loss and adjustment of element widths for digits 1, 2, 7, and 8 in EAN/UPC Symbols. This means that symbol

sizes may not match those input as target dimensions, but will vary in discrete steps within the permitted range, which will result in a more accurate symbol overall.

### 5.5.3.3.10.2. EAN/UPC Symbology

The main characteristic of the EAN/UPC Symbology that affects verification is the different treatment of the three sets of symbol characters for digits 1, 2, 7, and 8 from the remaining digits (0, 3, 4, 5, 6, and 9). The reference decode algorithm uses the combined width of both bars in these characters to discriminate between a 1 and a 7, and between a 2 and an 8, which are ambiguously decodable since they share the same set of edge-to-similar-edge modular dimensions. The addition to or subtraction from the element widths of 1/13 module is intended to increase the differences between the sums of the bar widths for each pair of ambiguous characters. The decodability parameter for these characters takes account of bar gain and loss whereas it does not for the remaining symbol characters. Consequently, a symbol not containing any of these four symbol characters may suffer substantial bar gain or loss without degrading its decodability, whereas a symbol that does contain one or more of them is likely to have a lower decodability grade, with the same amount of bar gain or loss. However, the laws of probability suggest that only some 6.9 percent of symbols would not be affected by this, so it is wise to be cautious and assume that bar gain or loss is a possible cause of a poor decodability grade for EAN/UPC Symbols. It is also wise (for process control purposes) not to assume that the decodability grade correlates with bar width deviation, but it is far safer and easier to rely on the traditional measurement of bar width deviation for adjusting the production process.

The measuring aperture for EAN/UPC Symbols, irrespective of X-dimension, is 6 mils (which is equivalent to 0.15 millimetre (0.006 inch)). This is not one of the four ISO-recommended standard default aperture sizes, which are 3, 5, 10, and 20 millimetres, but is usually available from verifier manufacturers. This diameter was based on measurement of symbols with various apertures and much test scanning in order to determine which aperture gave results correlating best with scanning performance.

### 5.5.3.3.10.3. GS1-128 Symbology

The important aspects to verify for a GS1-128 Symbol are its print quality, which is assessed in the standard way, and its formatting, which may need to be visually checked from the information output by the verifier. The Code 128 Symbology is an edge-to-similar-edge decodable symbology, but its reference decode algorithm also requires a check of the sum of the widths of the three bars in each character as part of its parity checking process. Consequently, its decodability is affected by bar gain or loss.

Measuring apertures for GS1-128 Symbols varies according to the application. For all applications except the GS1-128 Coupon Extended Code, an aperture of 10 millimetres is specified, giving a minimum acceptable grade of 1.5/10/670. The GS1 Common Currency Coupon Code requires an aperture of 6 millimetres and a minimum grade of 1.5/06/670.

Data contained in GS1-128 Symbols must be formatted according to these specifications for the use of Application Identifiers (AIs). Specific features to check are:

- Presence of Function 1 Symbol Character (FNC1) as a flag for the GS1 System subset of the Code 128 Symbol, in the first position after the Start Character
- Use of FNC1 as a field separator following non-predefined length AIs
- Sequencing of AIs, with pre-defined length AIs preceding non pre-defined length ones
- Length of data fields with fixed length AIs
- Correct formatting of data in all AI fields
- Absence of encoded parentheses around AIs

The extent to which a verifier can do this automatically will vary greatly among devices, even those that have GS1-128 Symbols as a specific symbology option.

#### 5.5.3.3.10.4. ITF-14 Symbology

ITF-14 Bar Code Symbols are, unlike the others used in the GS1 System, two-width (narrow/wide) symbols that cannot be decoded by the edge-to-similar-edge technique, but all element widths must be measured. They are, therefore, more subject to the problems caused by bar gain or loss.

The standard ISO verification technique is fully applicable to these symbols. However, in the GS1 System application, additional checks must be made to ensure that the X-dimension (magnification factor) is within the permitted range.

Measuring apertures for the ITF-14 Symbol are 10 millimetres for symbols with an X-dimension less than 0.635 millimetre and 20 millimetres for symbols with an X-dimension equal to or greater than 0.635 millimetre.

The minimum acceptable grade for symbols printed with the higher range of X-dimension (above 0.635 millimetre) is 0.5/20/670. This is because the brown corrugated substrates on which such symbols are often printed typically have a reflectance value below 40 percent, and sometimes below 30 percent, and cannot, therefore, ever achieve a Symbol Contrast better than 40 percent (the lower threshold for a grade 2 Symbol Contrast) no matter how dense the ink or how well the other attributes of the symbol are graded. As a result, the Scan Reflectance Profile (SRP) grade will most often be dictated by Symbol Contrast, so it cannot be higher than 1 for symbols on these materials, giving a maximum achievable overall symbol grade of 1.0.

Such symbols may also be affected by the inherent interference in the background reflectance caused by the substrate's composition, which may well lead to reduced defect grades and possibly low edge contrast and modulation values. It is, therefore, desirable to ensure that symbols printed on these corrugated materials are of as high a quality as possible in respect of the other parameters.

#### 5.5.3.3.11. Possible Causes of Less-Than-Perfect Verification Grades

##### 5.5.3.3.11.1. Reflectance Parameters

Symbol Contrast is governed by the reflectance of the substrate and ink. A symbol printed in black ink on a white paper will almost certainly achieve the top grade 4 for Symbol Contrast, as white papers typically have reflectance in excess of 75 percent, and black ink will usually have about 3 to 8 percent reflectance. Coloured backgrounds or coloured inks will affect the result. Highly glossy materials may also appear to have a lower background reflectance than expected. The worst case may be when printing on a corrugated brown fibre-board material, which may have a reflectance in a range between 27 and 40 percent, so even with a very dense, low reflectance ink it can never achieve better than the minimum passing grade 1 for Symbol Contrast (grade 1 includes Symbol Contrast values from 20 to 39 percent).

The causes of low Symbol Contrast and the solutions are:

- Background too dark: Use lighter or less glossy material, or change background colour (if printed) to one with higher reflectance
- Bars too light: Change bar colour for one with lower reflectance, and increase ink weight or print head temperature (thermal printing) (Watch for consequential increase in bar widths)
- Show-through of contents: Use more opaque material for package, or print opaque white underlay prior to printing symbol
- Show-through of imprint: Use more opaque labels

Minimum reflectance, or  $R_{min}$ , must always be equal to or less than half the highest reflectance value,  $R_{max}$ . In practice, this means that the reflectance of at least one bar must meet this criterion. For example, if  $R_{max}$  is 70 percent, at least one bar must have a reflectance of 35 percent or less. A symbol that fails on this parameter will almost certainly have a low Symbol Contrast grade also.

The cause of and solution for  $R_{min}$  being too high include:

- Bars too light: Change bar colour to one with lower reflectance, and increase ink weight or print head temperature (thermal printing) (Watch for consequential increase in bar widths)

Minimum Edge Contrast (ECmin) will always be lower than Symbol Contrast, but will only be a problem in itself if it approaches or drops below 15 percent (the pass/fail threshold). However, low edge contrast (EC) values, acceptable under this criterion, may still cause low modulation (MOD) grades.

The causes of a low value of ECmin and the possible remedies are:

- Local variations in background reflectance (e.g., fragments of darker material in a recycled material): Use a more consistent substrate or one with higher reflectance
- Local variations in inking of the bars: Adjust press settings to ensure even inking
- Show-through of contents: Use more opaque material for package, or print opaque white underlay prior to printing symbol
- Elements adjoining the edge in question are excessively narrow relative to the measuring aperture used: Increase X-dimension; ensure correct measuring aperture is used; ensure correct bar width adjustment (BWA) applied to Film Master/original symbol; print bars marginally narrower than spaces of same modular dimension

Modulation, being calculated as the percentage of Symbol Contrast represented by the ECmin, will be reduced for the same reasons as when ECmin is low in the symbol. A scanner will tend to see spaces as narrower than bars and also to see narrow elements as less distinct than wider ones. Consequently, if there is significant bar loss, modulation will be reduced. Measuring with an aperture that is too large for the X-dimension will also reduce modulation.

The causes of a low value of modulation (often listed as “MOD” on verification reports) and the possible remedies are:

- Local variations in background reflectance (e.g., fragments of darker material in a recycled material): Use a more consistent substrate or one with higher reflectance
- Local variations in inking of the bars: Adjust press settings to ensure even or darker inking
- Show-through of contents: Use more opaque material for package, or print opaque white underlay prior to printing symbol
- Element(s) adjoining the edge in question appear excessively narrow relative to the measuring aperture used: Increase X-dimension; ensure correct measuring aperture is used; apply correct BWA when originating symbol; print bars marginally narrower than spaces of same modular dimension

#### 5.5.3.3.12. Other Parameters

Decode is graded on a pass/fail basis by applying the reference decode algorithm to the edge positions and element widths determined for the symbol. A failure to decode may be evidence of the symbol being incorrectly encoded, which may include an incorrect Check Digit. It also may indicate either that the bars and spaces initially identified by the global threshold are too many or too few for a valid symbol or that one or more edge positions are ambiguous.

The possible causes of decode failure and possible remedies are:

- Symbol incorrectly encoded: Re-originate symbol; over-label with correctly encoded symbol
- Check Digit incorrectly calculated: Correct software error in origination system; re-originate symbol; over-label with correctly calculated symbol
- Gross element width errors due to excessive print gain or loss, or to defects: Apply correct bar width adjustment (BWA) when originating symbol; adjust press or printer settings

- Too many elements detected due to defects: Correct cause of defects; adjust press (relief printing processes) to reduce haloin; replace print head (thermal/ink-jet printing)
- Too few elements detected (failure to cross global threshold): Refer to solutions for edge contrast (EC)

In the ISO standard, a decode failure occurs because an incorrect number of elements has been perceived to be present, either because the profile of one or more elements has failed to cross the global threshold or because a gross defect has caused one element to be seen as three or more, corresponding to the separately graded Edge Determination failure in the ANSI standard, which may also be reported by some verifiers following the ANSI methodology.

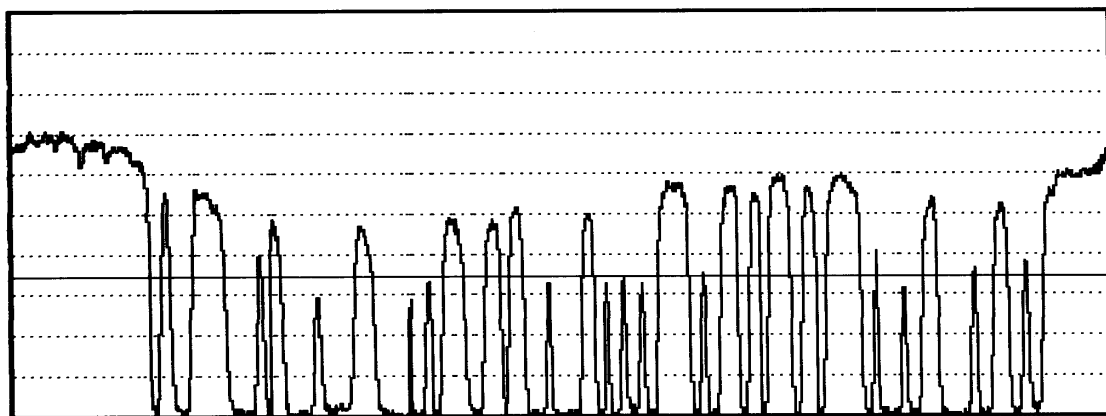
Figure 5.4.3.3.12 – 1 shows a symbol in which the narrow spaces have been partly filled in, reducing their contrast below the global threshold and causing an edge determination or decode failure. This could also be interpreted as an extreme example of modulation (MOD).

**Figure 5.5.3.3.12 - 1 Symbol with Edge Determination Problem**



Figure 5.5.3.3.12 - 2 illustrates a Scan Reflectance Profile (SRP) showing narrow space profiles failing to reach the global threshold, giving an (ISO) decode failure or (ANSI) edge determination failure.

**Figure 5.5.3.3.12 - 2 Scan Reflectance Profile with Narrow Space Profiles**



Decodability grades are influenced by bar gain or loss in most symbologies and by distortion of the symbol. Distortion can occur with relief printing processes, such as flexography, when the printing plate is stretched around the press cylinder with the bars parallel to the cylinder axis (e.g., at right angles to the print direction). A common reason for distortion with digitally-originated images is that they have been rescaled in graphics software, resulting in uneven addition or removal of pixels to or from the element widths. Print processes that tend to produce irregular bar edges, such as ink-jet and photogravure, will also be likely to give lower decodability grades.

The causes of a low value of decodability and the possible remedies are:

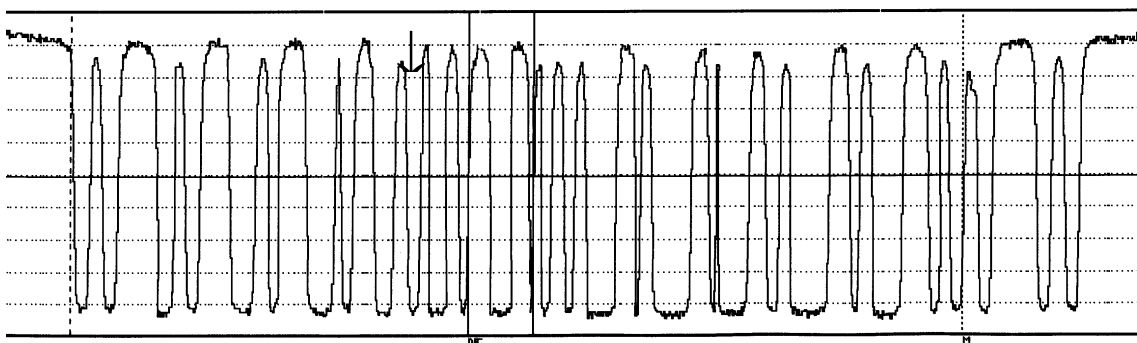
- Bar gain/loss (systematic): Apply correct bar width adjustment (BWA) when originating symbol; adjust press settings
- Element width gain/loss (non-systematic): Correct missing pixels (burnt-out print head elements, blocked ink-jet nozzles); rectify cause of defects
- Distortion of symbol (uneven stretching of flexographic plate; non-linear disproportioning in plate-making process): Print symbol with height of bars parallel to direction of printing; do not disproportion bar code image in plate-making
- Rescaling of digitally-originated images: Ensure symbol is created in correct size; ensure software matches module widths to integer number of pixels after all adjustments
- Irregular element edges (ink-jet, photogravure, screen process printing): Change print technology; increase X-dimension/magnification factor; re-orient symbol relative to cylinder engraving angle/screen mesh

The symbol in Figure 5.5.3.3.12 - 3 is taken from the GS1 Calibrated Conformance Standard Test Card and has an engineered low decodability grade of 50 percent. As may be determined from the accompanying Scan Reflectance Profile (SRP), just to the left of halfway across the symbol, the width of a two-module bar has been increased in the sixth digit (and since the character is a 1, its decodability is affected by bar width). Although the original symbol has a very consistent image density, the profile also shows the effect of modulation (MOD), most noticeably on the narrow spaces.

**Figure 5.5.3.3.12 - 3 Calibration Symbol with Engineered Low Decodability Grade**



**Figure 5.5.3.3.12 – 4 Scan Reflectance Profile of Symbol with Low Decodability Character**



Defects, which show as irregularities in the Scan Reflectance Profile, may be caused by spots of extraneous ink in Quiet Zones or in the spaces. Small voids (white areas) in the bars are also highlighted as defects. In symbols printed on recycled or some other materials, local variations in reflectance of the background will also show as defects. The significance of a defect is in direct relation to the depth of the irregularity it causes in the Scan Reflectance Profile.

Common causes and the most likely solutions include:

- Defective print head elements (thermal printing or ink-jet printing), which will tend to produce an unprinted line running through the symbol in the direction of printing: Clean or replace print head
- Satellite (ink droplets in the white are surrounding the printed bars): Clean head; change ink formulation
- Haloining (e.g., a double line impression where there should only be a single line impression): Adjust impression pressure and/or ink viscosity
- Incorrect matching of thermal transfer ribbons and substrate (poor adhesion of ink to surface): Use correct ribbon for substrate; use smoother substrate
- Measuring aperture too small: Use verifier with correct aperture

The use of a smaller or larger measuring aperture than specified for the symbol will produce misleading defect grades, and this is perhaps the strongest argument for ensuring that the right aperture size is used. Too small an aperture will exaggerate the apparent size of a defect; too large an aperture will tend to smooth it out.

Quiet Zones are a frequent source of scanning problems. Although the ISO standard does not directly require measurement of the Quiet Zones, it requires any additional requirements specified by the application specification to be graded on a pass/fail basis. The *GS1 General Specifications* establishes Quiet Zone requirements for all symbols used in the GS1 System, and a Quiet Zone less than the minimum width will, therefore, cause the profile grade to fail.

Possible causes of Quiet Zone failure and the remedies are:

- Printed box surrounding symbol or other interfering print: Enlarge box; ensure symbol registration to other print allows adequate margins; use Quiet Zone Indicators if possible
- Symbol too close to label edge: Adjust label feed; reposition symbol farther from edge; use larger label size or smaller symbol

#### 5.5.3.4. Print Process Characterisation Techniques

##### 5.5.3.4.1. Introduction

This section specifies when EAN/UPC Symbols can be printed at less than the current minimum specification of 0.264 millimetres or 10.4 mils X-dimension (80 percent magnification).

##### 5.5.3.4.2. Background

Many printer users have asked if the magnifications in the 75 to 80 percent range for EAN/UPC Symbols printed by thermal and laser on-demand printers are acceptable for use. The most common printing densities used by on-demand, bar code printers are 200 and 300 dpi. However, due to the constraints of the dot pitch, these printers cannot print an 80 percent symbol correctly. The nearest to 80 percent that these printers can print is 75.7 or 76.9 percent depending on the exact dot geometry.

Even though 80 percent magnification is the minimum value specified in the EAN/UPC Symbol specification, users of on-demand printers have used magnifications between 75 and 80 percent in Point-of-Sale scanning environments for years. They have done so with no significant reduction in scan rate, as compared to symbols printed precisely at 80 percent. Because larger in-specification EAN/UPC Symbols are always easier to scan, 80 percent symbols and larger are preferred. However, when an on-demand printer is required, the 75 to 80 percent EAN/UPC Symbols are an acceptable alternative given the conditions in Section 5.5.3.4.3.

### 5.5.3.4.3. New Qualifications for Printing

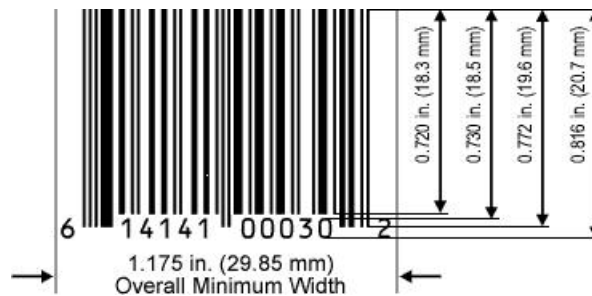
The allowance for EAN/UPC Symbol magnifications from 75 to 80 percent is only applicable to "on demand" (e.g., thermal or laser) print processes. For all other printing processes, 80 percent is attainable and is the minimum allowable size.

When printing a minimum symbol with any method of printing, the area provided for printing the symbol and the required Quiet Zone should never be less than the area required for an 80 percent symbol. This area can be derived from the total width of an 80 percent symbol times its height as shown in the dimensions in Figure 5.5.3.4.3 - 1.

When printing a minimum symbol with any method of printing, the symbol height should never be truncated below the 80 percent value (20.7 millimetres or 0.816 inch).

The minimum print quality grade should be the same for all EAN/UPC Symbols; at least an ISO/ANSI grade of 1.5 (or C). It is advisable to print EAN/UPC Symbols that are at least a 2.5 (B) grade at the time of printing regardless of size.

**Figure 5.5.3.4.3 - 1 EAN/UPC Symbol Shown with Minimum Height and Overall Width Dimensions for Magnifications of 75 Percent to 80 Percent**



**Note:** As you move from 80 to 75 percent magnification, the Quiet Zone increases from 0.0936 inch (2.38 millimetres) to 0.124 inch (3.16 millimetres) in order to keep the overall width constant at 1.175 inches (29.85 millimetres).

### 5.5.3.4.4. Summary

When printing with on-demand printers (e.g., thermal or laser) the resulting element widths for EAN/UPC Symbols should never be less than 75 percent magnification. If the symbol printed with element widths is less than 80 percent, then the overall symbol shall have both larger Quiet Zones and taller bars such that the resulting area is not less than that of 80 percent magnification symbols. The symbol print quality must still meet the EAN/UPC Symbol requirements of 1.5/06/670.

### 5.5.3.5. GS1 Bar Code Verification Template

#### 5.5.3.5.1. Introduction

This GS1 Bar Code Verification Template was developed in co-operation with retailers, manufacturers, logistic providers and equipment providers to ensure a common reporting approach on a global level. This helps ensure consistency regardless of where and by whom the symbols are tested thus removing the costly and inefficient requirements for multiple testing of identical symbols and reducing the cost of compliant equipment.

This template does not introduce any requirements in and of itself. The sole aim is to provide a common reporting format to measure compliance with the numbering and bar coding standards of GS1 laid down elsewhere in these GS1 General Specifications.

### 5.5.3.5.2. Background

GS1 has developed this verification template on the basis of ISO/IEC 15416 Bar Code Print Quality Test Specifications for Linear Symbols. This not only allows for assessing the quality of printed bar code symbols but also checks against other key aspects of GS1 System (symbol location, fit-for purposes, data integrity, etc).

A GS1 initiated Verifier Conformance Testing Project was conducted because of concerns expressed that different verifiers or verification services were unable to perform consistently. The perception was that different verifiers gave substantially different results when measuring the same symbol. A precisely defined test programme was performed under the auspices of GS1 and concluded that:

- All verifiers tested (each one ISO compliant) demonstrated the capability of consistent performance.
- Operators of verifiers require proper training and instruments require regular calibration in accordance with manufacturer recommendations.
- Most verifiers tested were capable of conforming to GS1 requirements

It is therefore important to stress the need for professional verification services and that bar code print quality should be integral part of an overall quality programme. Section 5.5.2.7 provides a quick reference list of symbol quality specifications depending on the symbol type, the application, or the identification number the symbol is carrying.

All GS1 user companies should perform quality control of bar code production and most GS1 Member Organisations offer a verification service. This report template may be used by any organisation or company as part of a quality programme while respecting the Copyright of the GS1 logo (or any heading or text that imply actual GS1 endorsement (subject to local licensing agreements such as accreditation programmes, which may allow exceptions)).

The template below highlighting critical issues relating to verification and provides a common template for reporting on the most common areas of application. In itself it is not a guarantee of scan performance and nor does it cover all applications of the GS1 Systems (e.g., GS1 DataMatrix).



<NAME> Issue Date <Date of Issue>  
 <Line one address>  
 <Line two address>  
 <Town>  
 <Postcode>  
**Product Description:** <Brand and Name of Product>  
**Type of bar code:** <Symbol Type>  
**Data encoded:** < Data Encoded>  
**Print Method:** <Print Method>  
**Number of bar codes on product:** <Number of Symbols>

**Please Note:** These assessments are based on meeting the minimum GS1 standards.  
 To ensure efficient scanning, the bar code should exceed the minimum.

## Testing Summary

<b>GS1 General Specifications for Linear Symbols tested environments:</b>	
1) Omni-directional Retail Point of Sale (POS)	PASS or FAIL or Not assessed
2) General Distribution (Automated scanning in Supply Chain)	PASS or FAIL or Not assessed
2.1) GS1 Logistic Label (SSCC)	PASS or FAIL or Not assessed
3) General Purpose Hand Scanning	PASS or FAIL or Not assessed
Complies to GS1 Symbol Location Recommendations	In/Out Spec (& comment on business critical issue)
ISO Symbol Grade	ISO <x.x>/06/660 (0.0 – 4.0) PASS/FAIL
Business Critical Comments	

## Technical Analysis of Symbol

GS1 Parameters	Comment Reference	Assessed	Within Standard Range	Required
Symbol Structure <sup>1</sup>			✓	(dependent on symbol encoded)
X-dimension <sup>2</sup> (magnification)		0.330	✓	0.264mm-0.660mm
Bar Code Height		26mm	✓	26.04mm
Quiet Zone (Left)			✓	3.63mm
Quiet Zone (Right)			✓	2.31mm
Human Readable			✓	One-to-one match with bar code data
Bar Code Width			✓	<165mm
Validity of GS1 Company Prefix			✓	
Data Structure			✓	(dependent on structure encoded)

ISO Parameters	Comment Reference	Grade ISO/ANSI	Within Standard Range	Required
Overall ISO Grade <sup>3</sup>		3.8/06/660	✓	>1.5
Decode		4.0	✓	>1.5
Symbol Contrast		3.8	✓	>1.5
Minimum Reflectance		4.0	✓	>1.5
Edge Contrast		4.0	✓	>1.5
Modulation		4.0	✓	>1.5
Defects		4.0	✓	>1.5
Decodability		4.0	✓	>1.5

Note 1 Includes Check Digits, ITF-14 wide-to-narrow ratio, etc.  
 Note 3 0.5 acceptable for ITF-14 with X-dimension > 0.635mm

Note 2 Information on conversion between ISO & ANSI and X-dimension & Magnification Factors is on the website:  
<http://www.gs1.org/productssolutions/barcodes/support/>

Additional Tests	ISO Symbol Grade (0.0 – 4.0) PASS/FAIL	General Comment
GS1-128 Application Identifiers encoded – See comments		Pass/Fail/Not assessed
(example) Multiple GS1-128 symbols - Row 2		
(example) Multiple GS1-128 symbols - Row 3		
<b>Educational Comments</b>		

### Notes (informative localised)

It is the responsibility of the brand owner to ensure the correct use of the GS1 Company Prefix and the correct allocation of the data content.  
 Rejection of products should not necessarily be based only on an out of specification results  
 Bar Code verifiers are measuring devices and are tools that can be used for assisting in quality control. The results are not absolute in that they do not necessarily prove or disprove that the bar code symbol will scan.  
 This report may not be amended after issue. In the event of a dispute over contents the version held at [TESTING AGENCY] will be deemed to be the correct and original version of this report.

### Important Note (normative localised)

This Verification Report may contain privileged and confidential information intended only for the use of the addressee named above. If you are not the intended recipient of this report you are hereby notified that any use, dissemination, distribution or reproduction of this message is prohibited. If you received this message in error please notify [TESTING AGENCY].

### Disclaimer (legal localised)

This report does not constitute evidence for the purpose of any litigation, and [TESTING AGENCY] will not enter into any discussion, or respond to any correspondence in relation to litigation.  
 Every possible effort has been made to ensure that the information and specifications in the Bar Code Verification Reports are correct, however, [TESTING AGENCY] expressly disclaims liability for any errors.

## 5.6. Linear Bar Codes – GS1 DataBar (Formerly RSS)

### 5.6.1. GS1 DataBar (Formerly RSS)

#### 5.6.1.1. Introduction

GS1 DataBar (formerly RSS) is a family of linear symbologies used within the GS1 System. There are three groups of GS1 DataBar symbols, two of which have a number of versions optimised for different application requirements.

The first group, which comprises GS1 DataBar Omnidirectional, GS1 DataBar Truncated, GS1 DataBar Stacked and GS1 DataBar Stacked Omnidirectional encodes AI (01) in a linear symbol. The second group is GS1 DataBar Limited (formerly RSS Limited) which encodes AI (01) in a linear symbol for use on small items that will not be scanned in an omnidirectional scanning environment. The third group, GS1 DataBar Expanded (formerly RSS Expanded) and GS1 DataBar Expanded Stacked (formerly RSS Expanded Stacked) encodes GS1 System primary item identification plus supplementary AI Element Strings, such as weight and “best before” date, in a linear symbol that can be scanned omnidirectionally by suitably programmed slot scanners.

GS1 DataBar Stacked is a variation of the first group of GS1 DataBar Symbology that is stacked in two rows and used when the normal symbol would be too wide for the application. It comes in two versions: a truncated version used for small item marking applications and a taller version that is designed to be read by omnidirectional scanners. GS1 DataBar Expanded can also be printed in multiple rows as a stacked symbol.

Any member of the GS1 DataBar family can be printed as a stand-alone linear symbol or as a component of a composite symbol with an accompanying two-dimensional (2D) Composite Component printed above the GS1 DataBar linear component.

The GS1 DataBar family is fully described in ISO/IEC 24724 (formerly RSS, now GS1 DataBar).

#### 5.6.1.1.1. Symbology Characteristics

The GS1 DataBar (formerly RSS) family consists of the following versions:

- GS1 DataBar Omnidirectional (formerly RSS-14)
- GS1 DataBar Truncated (formerly RSS-14 Truncated)
- GS1 DataBar Stacked (formerly RSS-14 Stacked)
- GS1 DataBar Stacked Omnidirectional (formerly RSS-14 Stacked Omnidirectional)
- GS1 DataBar Limited (formerly RSS Limited)
- GS1 DataBar Expanded (formerly RSS Expanded)
- GS1 DataBar Expanded Stacked (formerly RSS Expanded Stacked)

The characteristics of the GS1 DataBar family are:

- Encodable character set:
  - GS1 DataBar Omnidirectional, GS1 DataBar Truncated, GS1 DataBar Stacked, GS1 DataBar Stacked Omnidirectional and GS1 DataBar Limited: Digits 0 through 9 (with the restriction of GS1 DataBar Limited to 0 or 1 in the first digit)
  - GS1 DataBar Expanded versions: The GS1 System requires that only the subset of ISO/IEC 646 International Reference Version defined in these GS1 General Specifications

be used for Application Identifier (AI) Element Strings. Refer to Figure 7.12 – 1 for more details.

- Symbol character structure: Different (n,k) symbol characters are used for each member of the family, where each symbol character is n modules in width and is composed of k bars and k spaces
- Code type: Continuous, linear bar code symbology
- Maximum numeric data capacity (including implied Application Identifiers (AIs) where appropriate, but not including any encoded FNC1 characters):
  - All GS1 DataBar symbols except the expanded versions: AI (01) plus a 14-digit numeric item identification
  - GS1 DataBar Expanded versions: 74 numeric or 41 alphabetic characters
- Error detection:
  - GS1 DataBar Omnidirectional, GS1 DataBar Truncated, GS1 DataBar Stacked and GS1 DataBar Stacked Omnidirectional: mod 79 checksum
  - GS1 DataBar Limited: mod 89 checksum
  - GS1 DataBar Expanded versions: mod 211 checksum
- Character self-checking
- Bidirectionally decodable
- Quiet Zones: None required

#### 5.6.1.1.2. Additional Features

Additional GS1 DataBar (formerly RSS) features include:

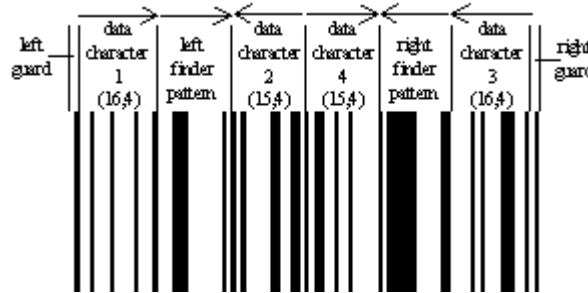
- Data compaction: Each member of the GS1 DataBar family has data compaction methods optimised for the data strings that it will encode. GS1 DataBar Expanded versions are also optimised for specific sequences of Application Identifiers (AIs) that are commonly used.
- Component linkage: All GS1 DataBar symbols include a linkage flag. If the linkage flag is 0, then the GS1 DataBar symbol stands alone. If the linkage flag is 1, then a 2D Composite Component and its separator pattern are printed above the GS1 DataBar symbol with the separator pattern aligned and contiguous to the GS1 DataBar symbol.
- Edge to similar edge decoding: All GS1 DataBar family data characters, finder patterns, and Symbol Check Characters can be decoded using edge-to-edge measurements.
- Large data characters: Unlike EAN/UPC Symbols, a GS1 DataBar symbol's data characters do not directly correspond to the encoded data character. The symbol's data characters encode thousands of possible combinations to increase the encoding efficiency. They are then combined mathematically to form the encoded data string.
- GS1-128 Symbol emulation: Readers set to the GS1-128 Symbol emulation mode transmit the data encoded within a GS1 DataBar symbol as if the data were encoded in one or more GS1-128 Symbols.

#### 5.6.1.2. The First Group of GS1 DataBar Symbols

The first group of GS1 DataBar symbols encodes the Element String AI (01). It has four versions: GS1 DataBar Omnidirectional, GS1 DataBar Truncated, GS1 DataBar Stacked, and GS1 DataBar Stacked Omnidirectional. All four versions encode data in an identical manner.

Figure 5.6.1.2 - 1 shows the structure of this group of GS1 DataBar symbols. These four different symbols, as explained below, contain four data characters and two finder patterns. The symbols are capable of being scanned in four separate segments, each consisting of a data character and an adjacent finder pattern. The two finder patterns together encode a modulo 79 check value for data security.

**Figure 5.6.1.2 - 1 First Group of GS1 DataBar Symbols Structure**



The left and right Guard Bar Patterns consist of a narrow space and narrow bar. These versions do not require a Quiet Zone.

**5.6.1.2.1. GS1 DataBar Omnidirectional**

The GS1 DataBar Omnidirectional Bar Code Symbol is designed to be read by an omnidirectional scanner, such as a retail slot scanner. Its dimensions are 96X wide, starting with a 1X space and ending with a 1X bar, by 33X high (where X is the width of a module). For example, a GS1 DataBar Omnidirectional Symbol with an X-dimension of 0.25 millimetre (0.010 inch) would be 24 millimetre (0.96 inch) wide and 8.25 millimetre (0.33 inch) high.

**Figure 5.6.1.2.1 - 1 GS1 DataBar Omnidirectional Bar Code Symbol**



**5.6.1.2.2. GS1 DataBar Truncated**

The GS1 DataBar Truncated Bar Code Symbol is a reduced height version of the GS1 DataBar Omnidirectional Bar Code Symbol that is designed for small items that will not need to be read by omnidirectional scanners. Its dimensions are 96X wide by 13X high (where X is the width of a module). For example, a GS1 DataBar Truncated Symbol with an X-dimension of 0.25 millimetre (0.010 inch) would be 24 millimetres (0.96 inch) wide by 3.25 millimetres (0.13 inch) high.

**Figure 5.6.1.2.2 - 1 GS1 DataBar Truncated Bar Code Symbol**



### 5.6.1.2.3. GS1 DataBar Stacked

The GS1 DataBar Stacked Bar Code Symbol is a reduced height two-row version of the GS1 DataBar Omnidirectional Bar Code Symbol that is designed for small items that will not need to be read by omnidirectional scanners. Its dimensions are 50X wide by 13X high (where X is the width of a module). For example, a GS1 DataBar Stacked Symbol with an X-dimension of 0.25 millimetre (0.010 inch) would be 12.5 millimetres (0.50 inch) wide by 3.25 millimetres (0.13 inch) high. Its structure includes a 1X high separator pattern between the two rows.

**Figure 5.6.1.2.3 - 1 GS1 DataBar Stacked Bar Code Symbol**



### 5.6.1.2.4. GS1 DataBar Stacked Omnidirectional

The GS1 DataBar Stacked Omnidirectional Bar Code Symbol is a full height, two-row version of the GS1 DataBar Omnidirectional Bar Code Symbol that is designed to be read by an omnidirectional scanner, such as a retail slot scanner. Its dimensions are 50X wide by 69X high (where X is the width of a module). For example, a GS1 DataBar Stacked Omnidirectional Symbol with an X-dimension of 0.25 millimetre (0.010 inch) would be 12.5 millimetres (0.50 inch) wide by 17.25 millimetres (0.69 inch) high. The height of 69X includes a 3X high separator pattern between two rows of 33X each.

**Figure 5.6.1.2.4 - 1 GS1 DataBar Stacked Omnidirectional Bar Code Symbol**



### 5.6.1.3. The Second Group of GS1 DataBar Symbols: GS1 DataBar Limited

The GS1 DataBar Limited Bar Code Symbol is the second group of GS1 DataBar symbols. It encodes the Element String AI (01). This Element String is based on the GTIN-12, GTIN-13, or GTIN-14 Data Structures. However, when using the GTIN-14 Data Structure, only the indicator value 1 is allowed. When encoding GTIN-14 Data Structures with an Indicator value greater than 1, one of the first group of GS1 DataBar symbols must be used: see section 5.6.1.2.

The GS1 DataBar Limited Bar Code Symbol is designed for small items that will not need to be read by omnidirectional Point-of-Sale (POS) scanners. Its dimensions are 74X wide, starting with a 1X space and ending with a 1X bar, by 10X high (where X is the width of a module). For example, a GS1 DataBar Limited Bar Code Symbol with an X-dimension of 0.25 millimetre (0.010 inch) would be 18.5 millimetres (0.74 inches) wide by 2.5 millimetres (0.10 inch) high.

**Figure 5.6.1.3 - 1 GS1 DataBar Limited Bar Code Symbol**



Figure 5.6.1.3 - 2 shows the structure of the GS1 DataBar Limited Bar Code Symbol. A GS1 DataBar Limited Symbol contains two data characters and a Symbol Check Character. The Symbol Check Character encodes a modulo 89 check value for data security.

**Figure 5.6.1.3 - 2 GS1 DataBar Limited Bar Code Symbol Structure**



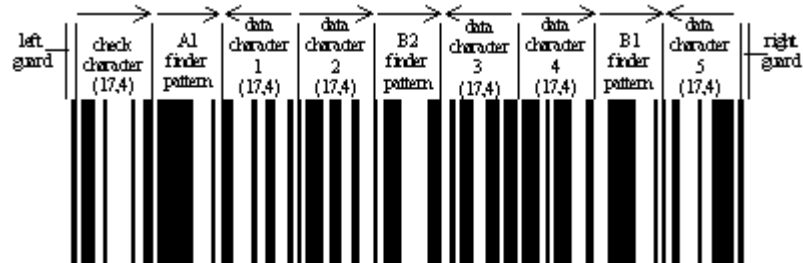
The left and right Guard Bar Patterns consist of a narrow space and narrow bar. The GS1 DataBar Limited Bar Code Symbol does not require a Quiet Zone.

### 5.6.1.4. The Third Group of GS1 DataBar Symbols: GS1 DataBar Expanded Versions

GS1 DataBar Expanded versions are the third group of GS1 DataBar symbols and are a variable length linear symbology capable of encoding up to 74 numeric or 41 alphabetic characters of AI Element String data. The two versions, GS1 DataBar Expanded and GS1 DataBar Expanded Stacked are designed to encode primary and supplementary data on items for Point-of-Sale (POS) and other applications. They have the same capabilities as a GS1-128 Symbol except that they are also designed to be scanned by omnidirectional slot scanners. They are designed for variable weight products, perishable products, traceable retail products, and coupons.

Figure 5.6.1.4 - 1 shows the structure of a six-segment GS1 DataBar Expanded Symbol. GS1 DataBar Expanded Symbols contain a Symbol Check Character, 3 to 21 data characters and 2 to 11 finder patterns, depending on the symbol length. GS1 DataBar Expanded is capable of being scanned in separate segments, each segment consisting of a data character or Symbol Check Character and the adjacent finder pattern. The Symbol Check Character encodes a modulo 211 check value for data security.

**Figure 5.6.1.4 - 1 GS1 DataBar Expanded Structure**



The left and right Guard Bar Patterns consist of a narrow bar and narrow space. GS1 DataBar Expanded versions do not require a Quiet Zone.

#### 5.6.1.4.1. GS1 DataBar Expanded

The GS1 DataBar Expanded Bar Code Symbol has a variable width (from 4 to 22 symbol characters, or a minimum of 102X wide and a maximum of 534X wide) and is 34X high (where X is the width of a module). The symbol starts with a 1X space and ends with either a 1X bar or space. For example, the GS1 DataBar Expanded Symbol shown in Figure 5.6.1.4.1 - 1 with an X-dimension of 0.25 millimetre (0.010 inch) would be 37.75 millimetres (1.51 inches) wide by 8.5 millimetres (0.34 inch) high.

**Figure 5.6.1.4.1 - 1 GS1 DataBar Expanded Bar Code Symbol**



**5.6.1.4.2. GS1 DataBar Expanded Stacked**

The GS1 DataBar Expanded Stacked Bar Code Symbol is a multi-row stacked version of GS1 DataBar Expanded. It can be printed in widths of 2 to 20 segments and can have from 2 to 11 rows. Its structure includes a 3X high separator pattern between rows. It is designed to be read by an omnidirectional scanner such as a retail slot scanner. The GS1 DataBar Expanded Stacked Symbol shown in Figure 5.6.1.4.2 - 1 with an X-dimension of 0.25 millimetre (0.010 inch) would be 25.5 millimetres (1.02 inches) wide by 17.75 millimetres (0.71 inch) high.

The white space at the end of the second row of the symbol shown in Figure 5.6.1.4.2 - 1 is not part of the symbol and can be used for other purposes, such as text.

**Figure 5.6.1.4.2 - 1: GS1 DataBar Expanded Stacked Bar Code Symbol**



GS1 DataBar Expanded Stacked is used when the symbol area or print mechanism is not wide enough to accommodate the full single-row GS1 DataBar Expanded Symbol. It is designed for variable weight products, perishable products, traceable retail products, and coupons.

**5.6.1.4.3. Compressed Element String Sequences**

While GS1 DataBar Expanded Symbols can encode any sequence of Application Identifier (AI) data up to the maximum capacity of the symbol, certain sequences of AI Element Strings have been selected for special compression in GS1 DataBar Expanded versions. If the application requires the use of the AI Element Strings in one of these sequences and they are used in the predefined sequence, a smaller symbol will result.

The selected sequences are two types: fixed length, where the sequence of selected AI Element Strings is the only data encoded, and open-ended, where the sequence occurs at the start of the symbol's data, and other AI Element Strings may be added following the sequence. If the data to be encoded in an GS1 DataBar Expanded Symbol starts with a sequence defined as fixed length but is followed by additional AI Element Strings, all the data will be encoded normally without special compression.

**5.6.1.4.3.1. Fixed-Length Sequences**

This section contains information on Fixed-Length Sequences.

#### 5.6.1.4.3.1.1. (01) and Weight with Limited Range

This sequence consists of the two Application Identifier (AI) Element Strings AI (01), followed by AI (3103), AI (3202), or AI (3203) for weight. The AI (01) Element String must start with an Indicator value of 9 for variable measure. Using AI (3103) (weight in grams), the special compression can only be applied up to a maximum weight of 32.767 kilograms. Using AI (3202) (weight in 0.01 pounds) the special compression can only be applied up to a maximum weight of 99.99 pounds. Using AI (3203) (weight in 0.001 pounds) the special compression can only be applied up to a maximum weight of 22.767 pounds. If the weight is in excess of these values, the sequence defined in Section 5.6.1.4.3.1.2 still enables special compression to be performed.

#### 5.6.1.4.3.1.2. AI (01): Weight and Optional Date

This sequence consists of the two or three Application Identifier (AI) Element Strings AI (01), AI (310n), or (320n) for weight (n ranging from 0 to 9) and optionally AI (11), AI (13), AI (15), or AI (17) for date. The AI (01) Element String must start with an Indicator value of 9 for variable measure. If the date is not needed, this sequence still gives additional compression when the weight is outside the ranges required by the AI (01) and weight with limited range sequence above.

#### 5.6.1.4.3.2. Open-Ended Sequences

This section contains information on Open-Ended Sequences.

#### 5.6.1.4.3.2.1. AI (01) and Price

This sequence consists of the two Application Identifier (AI) Element Strings, AI (01), followed by AI (392x) for price or AI (393x) for price with ISO currency code (where x is in the range of 0 to 3). The AI (01) Element String must start with an Indicator value of 9 for variable measure. For example, this sequence is used for an AI (01) Element String, price and weight, because the fixed-length sequence AI (01) and weight does not give additional compression if the AI Element String for price is added to the end since the length of the sequence is fixed.

#### 5.6.1.4.3.2.2. AI (01)


Any sequence that starts with Application Identifier (AI) (01) will have special compression applied to the AI (01). So when the data includes AI (01), it should always be the first Element String encoded.

#### 5.6.1.5. Human Readable Interpretation in GS1 DataBar Symbols

The Human Readable Interpretation of data in a bar code should be shown below the bar code symbol.

The precise location of the human readable characters and the font used to represent them are not specified for the GS1 DataBar Symbol. However, characters should be clearly legible (such as OCR-B) and must be obviously associated with the symbol.

Application Identifiers (AIs) should be clearly recognisable to facilitate key entry. This is achieved by putting the AI between parentheses in the Human Readable Interpretation.

 **Note:** The parentheses are not part of the data and are not encoded in the bar code symbol, following the same principle that applies to GS1-128 Symbols.

As an option, the data title (see Section 3.2) may be associated with the data instead of using the AI numbers.

Figure 5.6.1.5 - 1 shows the weight and price identified with text.

**Figure 5.6.1.5 - 1 The Human Readable Interpretation**

### 5.6.1.6. Data Transmission and Symbology Identifier Prefixes

#### 5.6.1.6.1. Default Transmission Mode

The GS1 System requires the use of symbology identifiers. GS1 DataBar (formerly RSS) family symbols are normally transmitted using symbology identifier prefix "je0" (see Section 5.1.2). For example, an GS1 DataBar Symbol encoding AI (01) Element String 10012345678902 produces the transmitted data string "je00110012345678902." Data transmission follows the Rules for Encoding/Decoding Element Strings in GS1 symbologies using GS1 Application Identifiers (see Appendix [5.9](#) )

If a 2D Composite Component accompanies a GS1 DataBar family linear symbol, the AI Element String data from the 2D Composite Component immediately follows the linear component's data. However, readers have an option to transmit only the linear component data and ignore the 2D Composite Component.

#### 5.6.1.6.2. GS1-128 Symbol Emulation Mode

Readers also have an option for GS1-128 Symbol emulation mode. This mode emulates the GS1-128 Symbology for data transmission. This mode is used for applications programmed for GS1-128 but not yet programmed to recognise the symbology identifier prefix "je0." The symbology identifier for GS1-128 emulation mode is "jC1." GS1 DataBar Expanded Symbols that exceed 48 data characters are transmitted as two messages so as not to exceed the maximum GS1-128 Symbol message length. Each of the two messages has a symbology identifier prefix of "jC1" and does not exceed 48 data characters. The two messages are split at a boundary between two Element Strings. This mode is inferior to the normal transmission mode as message integrity may be lost when a message is split.

#### 5.6.1.7. Width of a Module (X-dimension)

The range of the X-dimension will be defined by the application specification, having due regard to the availability of equipment for the production and reading of symbols and complying with the general requirements of the application.

The X-dimension shall be constant throughout a given symbol.

#### 5.6.1.8. Height of Symbol

The height of a symbol is a multiple of the X-dimension defined by the type of GS1 DataBar Symbology given in Sections [5.6.1.2.1](#), [5.6.1.2.2](#), [5.6.1.2.3](#), [5.6.1.2.4](#), [5.6.1.3](#), [5.6.1.4.1](#), and [5.6.1.4.2](#).

### 5.6.1.9. Print Quality Grade

The International Standard *ISO/IEC 15416* methodology should be used for measuring and grading the GS1 DataBar family of symbols. The *ISO/IEC 15416* print quality specification is functionally identical to the older ANSI and CEN print quality specifications. The print quality grade is measured by verifiers that comply with the standard. The grade includes a grade level, measuring aperture, and the wavelength of light used for the measurement.

The minimum quality grade for GS1 DataBar Symbols is:

**1.5 / 6 / 670**


-Where-

- 1.5 is the overall symbol quality grade.
- 6 is the measuring aperture reference number (corresponding to an 0.15 millimetre or 0.006 inch diameter aperture).
- 670 is the peak response wavelength in nanometres.

In addition to the minimum print quality grade, all elements in the row separator patterns should be visually distinguishable.

### 5.6.1.10. Advice for Selecting the Symbology

Any use of GS1 DataBar should comply with GS1 System global application guidelines. GS1 DataBar is not meant to replace other GS1 System Symbologies. Existing applications that are satisfactorily utilising EAN/UPC Symbols, ITF-14 Symbols, or GS1-128 Symbols should continue to use them.

 **Note:** Scanning systems that need to read GS1 DataBar Symbols must be appropriately programmed.

If GS1 DataBar is used on items that will be read by omnidirectional slot scanners, then GS1 DataBar Omnidirectional, GS1 DataBar Stacked Omnidirectional, GS1 DataBar Expanded or GS1 DataBar Expanded Stacked should be used. If only an AI (01) is to be encoded, then GS1 DataBar Omnidirectional or GS1 DataBar Stacked Omnidirectional should be used. The selection of one or the other depends on the aspect ratio of the area available for the symbol.

If supplementary Application Identifier (AI) Element Strings are required or the primary identification has an AI other than AI (01), then GS1 DataBar Expanded or GS1 DataBar Expanded Stacked must be used. The selection of one or the other depends on the width of the print head or the area available for the symbol.

If GS1 DataBar is used on small items that do not need omnidirectional scanning capability, then GS1 DataBar Stacked, GS1 DataBar Limited, or GS1 DataBar Truncated should be used. GS1 DataBar Limited cannot be used to encode a GTIN-14 Data Structure with an Indicator value greater than 1. Otherwise GS1 DataBar Truncated or GS1 DataBar Stacked must be used. GS1 DataBar Stacked is the smallest symbol; however, as the heights of both rows are very low, it is harder to scan and cannot be used with wand scanners. If space is available, GS1 DataBar Limited can be used for number structures that it can encode. Otherwise GS1 DataBar Truncated should be used for GTIN-14 Data Structures with an Indicator value greater than 1.

If the symbol is a GS1 DataBar Composite Symbol, then using a wider GS1 DataBar Symbol such as GS1 DataBar Truncated instead of GS1 DataBar Limited may be preferable because the wider companion 2D Composite Component may result in a GS1 DataBar Composite Symbol of lower overall height even though the GS1 DataBar component itself is slightly taller.

If the data capacity in a two-column or three-column CC-B 2D Composite Component is inadequate to encode the required 2D component's data message, then the linear component can be changed to

increase the number of columns of the companion CC-B component. This will increase the maximum data capacity of the CC-B component as shown in Figure 5.6.1.10 - 1.

**Figure 5.6.1.10 – 1 Data Capacity of CC-B**

Number of CC-B Columns	Used with	Maximum Numeric Characters	Maximum Alpha Characters
2	GS1 DataBar Stacked GS1 DataBar Stacked Omnidirectional	95	55
3	GS1 DataBar Limited	219	127
4	GS1 DataBar Omnidirectional GS1 DataBar Expanded GS1 DataBar Expanded Stacked	338	196

## 5.7. Two Dimensional Bar Codes – GS1 DataMatrix Symbology

### 5.7.1. Introduction

This section of the *GS1 General Specifications* addresses some of the technical aspects of the two-dimensional bar code symbology called GS1 DataMatrix. GS1 DataMatrix is a standalone, two-dimensional matrix symbology that is made up of square modules arranged within a perimeter finder pattern. Unlike a Composite Component symbol (see Section 5.8.1), GS1 DataMatrix does not require a linear symbol. GS1 DataMatrix has been used in the public domain since 1994.

This section provides only a brief technical description and overview of the GS1 DataMatrix symbology. A more detailed technical specification can be found in the International Standard *ISO/IEC 16022*. The GS1 System has adopted GS1 DataMatrix partly because it can encode GS1 System data structures and offers other technical advantages. Its compact design and the existence of various production methods that accommodate placing the symbology onto various substrates offer certain advantages over other symbologies currently in the GS1 System.

Data Matrix ISO version ECC 200 is the only version that supports GS1 System data structures, including Function 1 Symbol Character. The ECC 200 version of Data Matrix uses Reed-Solomon error correction, and this feature helps correct for partially damaged symbols. In the remainder of this section, the ECC 200 version of Data Matrix is assumed when the symbology is described as GS1 DataMatrix. This version of Data Matrix is similar in stability to ISO versions of current GS1 System symbologies.

Implementation of GS1 DataMatrix shall be done per approved GS1 System application guidelines. This section will not describe the specific applications. The user needs to refer to specific application standards and guidelines in other sections of these *GS1 General Specifications* as they are approved for use. However, some of the production processes that can be used to produce GS1 DataMatrix Symbols are as follows:

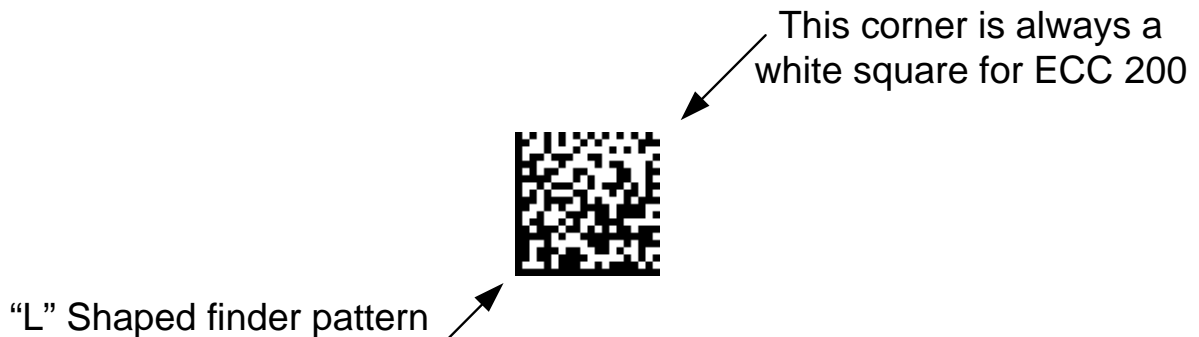
- Direct part marking, such as is done by dot peening on items, such as automotive, aircraft metal parts, medical instruments, and surgical implants
- Laser or chemically etched parts with low contrast or light marked elements on a dark background (e.g., circuit boards and electronic components, medical instruments, surgical implants)
- High-speed ink jet printed parts and components where the marked dots cannot form a scannable linear symbol

- Very small items that require a symbology with a square aspect ratio and/or cannot be marked within the allocated packaging space by existing GS1 DataBar (formerly RSS) and Composite Symbols

GS1 DataMatrix Symbols are read by two-dimensional imaging scanners or vision systems. Most other scanners that are not two-dimensional imagers cannot read GS1 DataMatrix. GS1 DataMatrix Symbols are restricted for use with new niche applications that will involve imaging scanners throughout the supply chain.

## 5.7.2. GS1 DataMatrix Features and Symbol Basics

Figure 5.7.2 - 1 GS1 DataMatrix Symbol



- Figure 5.7.2 – 1 represents a GS1 DataMatrix Symbol with 20 rows and 20 columns (including the perimeter finder pattern but not including Quiet Zones).
- GS1 DataMatrix solid “L” shaped finder or alignment pattern is one module wide.
- GS1 DataMatrix Quiet Zone is one module wide on all four sides. As with other bar code Quiet Zones, do not print in this area.
- ECC 200 symbols can always be recognized from older versions of Data Matrix because the corner opposite the middle of the finder pattern is a zero module or white in normal print.
- For square GS1 DataMatrix symbols, only an even number of rows and columns exist. Depending on data requirements, symbols can range from 10 row by 10 columns (10 x10) to 144x144 (including finder pattern but not the Quiet Zone).
- For normal printing, a module is one X by one X in dimension. Representation of data: A dark module is a binary one and a light module is a binary zero (or a light module is a binary one and a dark module is a binary zero for a symbol with reflectance reversal).
- ECC 200 (ECC = Error Checking and Correction) that uses Reed-Solomon error correction. Figure 5.7.3.2 – 1 ECC 200 Square Symbol Attributes, shows the fixed amounts of error correction associated for each allowable Data Matrix Symbol size.
- FNC1 for GS1 System compatibility can be encoded at the beginning of the data string and as a group separator. When a FNC1 is used as a group separator, it shall be represented in the transmitted message by the ASCII character <GS> (ASCII value 29).
- Encodable character set:
  - Values 0 - 127 in accordance with *ISO/IEC 646* International Reference Version (e.g., all 128 ASCII characters)
  - Values 128 - 255 in accordance with *ISO/IEC 8859-1*; Latin alphabet No. 1. These are referred to as extended ASCII.

- The GS1 System requires that only the subset of *ISO/IEC 646* International Reference Version defined in these *GS1 General Specifications* be used for Application Identifier (AI) Element Strings.
- Data characters per symbol (for the maximum symbol size):
  - Alphanumeric data: up to 2335 characters
  - Eight-bit byte data: 1556 characters
  - Numeric data: 3116 digits
- Large, square ECC symbols (at least 32 X32) will include alignment patterns to separate the data regions.
- Code type: matrix (Composite Component is a stacked type)
- Orientation independence: Yes (requires a two-dimensional imaging scanner)
- Summary of additional features inherent or optional in GS1 DataMatrix:
  - Reflectance reversal: (Inherent) Symbols can be read when marked so that the image is either dark on light or light on dark.
  - Rectangular symbols: Six symbol formats are specified in a rectangular form.
  - Extended Channel Interpretation (ECI) capability allows GS1 DataMatrix to encode data from other alphabets.

### 5.7.3. GS1 DataMatrix Symbology

The technical description of GS1 DataMatrix contained within this section provides additional information based on ISO technical specification 16022, and it is provided as a further aid in the development of specific applications. GS1 DataMatrix Symbols shown in the following subsections have been magnified to show detail.

#### 5.7.3.1. Square and Rectangular Formats

GS1 DataMatrix may be printed in a square or rectangular format. The square format is usually used as it has a larger range of sizes and is the only format available for symbols encoding a large amount of data. The largest rectangular symbol can encode 98 digits, while the largest square symbol can encode 3,116 digits. An enlarged rectangular symbol and an equivalent square symbol are shown in Figure 5.7.3.1 - 1.

**Figure 5.7.3.1 - 1 Rectangular and Square GS1 DataMatrix Symbols**

(Specific applications are not used in the data encodation. Both symbols contain the same data)



#### 5.7.3.2. GS1 DataMatrix Symbol Sizes

GS1 DataMatrix Symbology has multiple sizes to match various data content (see Figure 5.7.3.2 - 1). GS1 DataMatrix Symbols have 24 sizes of the square format ranging from 10 by 10 modules up to 144 by 144 modules, not including the 1-X surrounding Quiet Zone. The rectangular format has 6 sizes from 8 by 18 modules up to 16 by 48 modules, not including the 1-X surrounding Quiet Zone. GS1

DataMatrix sizes of 52 by 52 or larger have 2 to 10 interleaved blocks of Reed-Solomon error correction codewords.

The term “codeword” is used often to describe attributes concerning the encodation of data into GS1 DataMatrix Symbols. *ISO 16022* defines codeword as “A symbol character value. An intermediate level of coding between source data and the graphical encodation in the symbol.” Codewords are typically eight bits of data. FNC1, two numerics, and one alpha all take up one codeword each.

**Figure 5.7.3.2 - 1 ECC 200 Square Symbol Attributes\*\*\***

Symbol Size*		Data Region		Mapping	Total		Reed-Solomon		Inter-	Data Capacity			Error	Max. Correctable
Row	Col	Size	No.	Matrix Size	Data	Error	Data	Error	leaved Blocks	Num. Cap.	Alphanum. Cap.	Byte Cap.	Correction Overhead %	Codeword Error/Erasure
10	10	8x8	1	8x8	3	5	3	5	1	6	3	1	62.5	2/0
12	12	10x10	1	10x10	5	7	5	7	1	10	6	3	58.3	3/0
14	14	12x12	1	12x12	8	10	8	10	1	16	10	6	55.6	5/7
16	16	14x14	1	14x14	12	12	12	12	1	24	16	10	50	6/9
18	18	16x16	1	16x16	18	14	18	14	1	36	25	16	43.8	7/11
20	20	18x18	1	18x18	22	18	22	18	1	44	31	20	45	9/15
22	22	20x20	1	20x20	30	20	30	20	1	60	43	28	40	10/17
24	24	22x22	1	22x22	36	24	36	24	1	72	52	34	40	12/21
26	26	24x24	1	24x24	44	28	44	28	1	88	64	42	38.9	14/25
32	32	14x14	4	28x28	62	36	62	36	1	124	91	60	36.7	18/33
36	36	16x16	4	32x32	86	42	86	42	1	172	127	84	32.8	21/39
40	40	18x18	4	36x36	114	48	114	48	1	228	169	112	29.6	24/45
44	44	20x20	4	40x40	144	56	144	56	1	288	214	142	28	28/53
48	48	22x22	4	44x44	174	68	174	68	1	348	259	172	28.1	34/65
52	52	24x24	4	48x48	204	84	102	42	2	408	304	202	29.2	42/78
64	64	14x14	16	56x56	280	112	140	56	2	560	418	277	28.6	56/106
72	72	16x16	16	64x64	368	144	92	36	4	736	550	365	28.1	72/132
80	80	18x18	16	72x72	456	192	114	48	4	912	682	453	29.6	96/180
88	88	20x20	16	80x80	576	224	144	56	4	1152	862	573	28	112/212
96	96	22x22	16	88x88	696	272	174	68	4	1392	1042	693	28.1	136/260
104	104	24x24	16	96x96	816	336	136	56	6	1632	1222	813	29.2	168/318
120	120	18x18	36	108x108	1050	408	175	68	6	2100	1573	1047	28	204/390
132	132	20x20	36	120x120	1304	496	163	62	8	2608	1954	1301	27.6	248/472
144	144	22x22	36	132x132	1558	620	156	62	8**	3116	2335	1556	28.5	310/590
							155	62	2**					

**Figure 5.7.3.2 - 2 ECC 200 Rectangular Symbol Attributes\*\*\***

Symbol Size*		Data Region		Mapping	Total		Reed-Solomon		Inter-	Data Capacity			Error	Max. Correctable
Row	Col	Size	No.	Size	Block s	Cap.	Cap.	Cap.	leaved	Num.	Alphanum	Byte	Correction	Codeword
									Blocks	Cap.	Cap.	Cap.	Overhead %	Error/Erasure
8	18	6x16	1	6x16	5	7	5	7	1	10	6	3	58.3	3/+
8	32	6x14	2	6x28	10	11	10	11	1	20	13	8	52.4	5/+
12	26	10x24	1	10x24	16	14	16	14	1	32	22	14	46.7	7/11
12	36	10x16	2	10x32	22	18	22	18	1	44	31	20	45.0	9/15
16	36	14x16	2	14x32	32	24	32	24	1	64	46	30	42.9	12/21
16	48	14x22	2	14x44	49	28	49	28	1	98	72	47	36.4	14/25

**Notes:**

- \* Symbol size does not include Quiet Zones.
- \*\* In the largest symbol (144x144), the first eight Reed-Solomon blocks shall be 218 codewords long encoding 156 data codewords. The last two blocks shall encode 217 codewords (155 data codewords). All the blocks have 62 error correction codewords.
- \*\*\* Equivalent to Table 7 in the international standard ISO-16022, second edition, 2006-09-15.

The square format is divided into 4 to 36 data regions for symbols sized 32 by 32 modules and larger. The rectangular format symbols may also be divided into two data regions. Each data region is separated from the other regions by alignment patterns that consist of an alternating pattern of ones and zeroes and a solid line of ones (a dark line when there is no reflectance reversal). Figure 5.7.3.2 - 3 shows a four-segment square symbol on the left and a two-segment rectangular symbol on the right, each with hypothetical data shown to create the effect.

**Figure 5.7.3.2 - 3 Segmented GS1 DataMatrix Symbols: Square and Rectangular Formats**

(Sizes of these GS1 DataMatrix Symbols are larger than what would be used in a typical application so that typical alignment patterns can be easily seen.)



**5.7.3.3. Data Transmission and Symbology Identifier Prefixes**

The GS1 System requires the use of symbology identifiers. GS1 DataMatrix uses the symbology identifier of "]d2" (see Figure 5.7.3.3 - 1) for GS1 System compliant symbols that have a leading FNC1 character. This indicates that Application Identifier (AI) data is encoded equivalent to the symbology identifier "]C1" for GS1-128 Symbols and "]e0" for GS1 DataBar (formerly RSS) and Composite

Symbols. For more information on symbology identifiers, see the International standard *ISO/IEC 15424* Information technology — Automatic identification and data capture techniques — Data Carrier Identifiers.

For example, a GS1 DataMatrix Symbol encoding AI (01) Element String 10012345678902 produces the transmitted data string “jd20110012345678902.” Data transmission follows the same principles that apply to the concatenation of AI Element Strings in any GS1 BarCode that encodes Application Identifiers (see Section 7.9).

**Figure 5.7.3.3 - 1 Symbology Identifier for Data Matrix ECC 200**

	Message Content	Separator
jd2	Standard AI Element Strings	None

#### 5.7.3.4. Width and Height of a Module (X)

The range of the X-dimensions will be defined by the application specification, having due regard to the availability of equipment for the production and reading of symbols and complying with the general requirements of the application.

The X-dimension shall be constant throughout a given symbol. The X-dimension should apply to both the width and height of the modules.

#### 5.7.3.5. Symbol Quality Grade

The International Standard *ISO/IEC 15415* Information technology - Automatic identification and data capture techniques - Bar code symbol print quality test specification - Two-dimensional symbols methodology shall be used for measuring and grading GS1 DataMatrix. The print quality grade is measured by verifiers that comply with the standard. The grade includes a grade level, measuring aperture, the wavelength of light used for the measurement, and the illumination angle relative to the symbol.

A symbol grade is only meaningful if it is reported in conjunction with the illumination and aperture used. It should be shown in the format grade/aperture/light/angle, where:

- "grade" is the overall symbol grade as defined in *ISO/IEC 15415* Information technology - Automatic identification and data capture techniques - Bar code symbol print quality test specification - Two-dimensional symbols (e.g., the arithmetic mean to one decimal place of the Scan Reflectance Profile or scan grades). For GS1 DataMatrix, the grade number may be followed by an asterisk (\*) which indicates that the surroundings of the symbol contain extremes of reflectance that may interfere with reading. For most applications, this should be specified as causing the symbol to fail.
- "aperture" is the diameter in thousandths of an inch (to the nearest thousandth) of the synthetic aperture defined in *ISO/IEC 15415* Information technology - Automatic identification and data capture techniques - Bar code symbol print quality test specification - Two-dimensional symbols.
- "light" defines the illumination: A numeric value indicates the peak light wavelength in nanometres (for narrow band illumination); the alphabetic character W indicates that the symbol has been measured with broadband illumination (white light) the spectral response characteristics of which must imperatively be defined or have their source specification clearly referenced.
- "angle" is an additional parameter defining the angle of incidence (relative to the plane of the symbol) of the illumination. It shall be included in the reporting of the overall symbol grade when the angle of incidence is other than 45 degrees. Its absence indicates that the angle of incidence is 45 degrees.

- ✔ **Note:** This international standard provides for 30 degrees and 90 degrees illumination in addition to the default 45 degrees.

The aperture is normally specified as being 80% of the minimum X-dimension allowed for the application. The printing method must produce the GS1 DataMatrix "L" pattern with gaps between the dots less than 25% of the specified aperture. If symbols with greater than the minimum X dimension are allowed by the application, the same absolute maximum gap dimension must be maintained.

#### Examples:

- 2,8/05/660 would indicate that the average of the grades of the Scan Reflectance Profiles, or of the scan grades, was 2,8 when these were obtained with the use of a 0,125 millimetre aperture (ref. no. 05) and a 660 nanometre light source, incident at 45 degrees.
- 2,8/10/W/30 would indicate the grade of a symbol intended to be read in broadband light, measured with light incident at 30 degrees and using a 0,250 millimetre aperture (ref. no. 10), but would need to be accompanied either by a reference to the application specification defining the reference spectral characteristics used for measurement or a definition of the spectral characteristics themselves.
- 2,8/10/670\* would indicate the grade of a symbol measured using a 0,250 millimetre aperture (ref. no. 10), and a 670 nanometre light source, and indicates the presence of a potentially interfering extreme reflectance value in the surroundings of the symbol.

Recommended symbol grades for GS1 DataMatrix are identified in individual applications in Section 5.5.

#### 5.7.3.6. Advice for Selecting the Symbology

Any use of GS1 DataMatrix should comply with GS1 System global application guidelines and be restricted to those applications defined by the GS1 System for GS1 DataMatrix. GS1 DataMatrix will not replace other GS1 System Symbologies. Existing applications that are satisfactorily utilising EAN/UPC Symbols, ITF-14 Symbols, GS1-128 Symbols, GS1 DataBar (formerly RSS) Symbols, or Composite Symbols should continue to use them.

- ✔ **Note:** Scanning systems that need to read GS1 DataMatrix Symbols must be 2D imaging scanners and be appropriately programmed to read the GS1 System version of Data Matrix or ECC 200.

#### 5.7.3.7. Human Readable Interpretation of GS1 DataMatrix Symbols

The Human Readable Interpretation of the primary Application Identifier (AI) Element String encoded in the GS1 DataMatrix Symbol should be shown with the symbol. How the human readable data will be shown shall be determined by the specific application guidelines. Typical conventions, as used for GS1 DataBar (formerly RSS) and Composite Component Symbols, place the key information, such as the Global Trade Item Number (GTIN), in the human readable data underneath the bar code symbol, while secondary information is placed above. The characters should be clearly legible (such as OCR-B) and must be obviously associated with the symbol.

Als should be clearly recognisable to facilitate key entry. This is achieved by putting the AI between parentheses in the Human Readable Interpretation.

- ✔ **Note:** The parentheses are not part of the data and are not encoded in the bar code symbol, following the same principles that apply to GS1-128 Symbols and GS1 DataBar Expanded Symbols (formerly RSS Expanded).

For GS1 DataMatrix Symbols encoding large amounts of data, it may not be practical to display all the data in Human Readable Interpretation form. Even if there is space to show it in this form, it may not be practical to key enter that much data. In these instances, some of the data may be omitted from the Human Readable Interpretation. However, primary identification data (GS1 System keys), such as the GTIN, must always be shown. Application specifications may provide additional guidance on Human Readable Interpretation.

## 5.8. Composite Bar Codes

### 5.8.1. Composite Symbology Introduction

The Composite Symbology integrates both a GS1 System linear symbol and a 2D Composite Component as a single symbology. There are three types of Composite Symbols A, B and C, each with different encoding rules. The encoder model is designed to automatically select the appropriate type and optimise.

The linear component encodes the item's primary identification. The adjacent 2D Composite Component encodes supplementary data, such as a batch number and expiration date. The Composite Symbol always includes a linear component so that the primary identification is readable by all scanning technologies. The Composite Symbol always includes a multi-row 2D Composite Component that can be read with linear- and area-CCD scanners, and with linear and rastering laser scanners.

The Composite Symbology is described in the Automatic Identification Manufacturers, Inc. AIM ITS 99-002 - International Symbology Specification - Composite Symbology.

#### 5.8.1.1. Composite Symbology Characteristics

The characteristics of the Composite Symbology are:

- Encodable character set:
  - Linear components:
    - EAN/UPC Symbol, GS1 DataBar-14 Symbol versions, and GS1 DataBar Limited Symbol (formerly RSS Limited): digits 0 through 9
    - GS1-128 Symbol and GS1 DataBar Expanded Symbol: The GS1 System requires that only the subset of ISO/IEC 646 International Reference Version defined in these GS1 General Specifications be used for Application Identifier (AI) Element Strings. Refer to Figure 7.12 – 1 for more details.
  - 2D Composite Components:
    - All types: GS1-128 Symbols and GS1 DataBar Expanded Symbols together with the symbol Separator Character
    - Additionally, for CC-B and CC-C: 2D Composite Component escape character
- Symbol character structure: Various (n,k) symbol characters are used in accordance with the underlying symbology of the selected linear and 2D Composite Components of the symbol.
- Code type:
  - Linear component: continuous, linear bar code symbology
  - 2D Composite Component: continuous, multi-row bar code symbology
- Maximum numeric data capacity:
  - Linear component:
    - GS1-128 Symbol: up to 48 digits
    - EAN/UPC Symbol: 8, 12, or 13 digits

- GS1 DataBar Expanded Symbol (formerly RSS Expanded): up to 74 digits
- Other GS1 DataBar Symbols: 16 digits
- 2D Composite Component:
  - CC-A: up to 56 digits
  - CC-B: up to 338 digits
  - CC-C: up to 2,361 digit
- Error detection and correction:
  - Linear component: a modulo check value for error detection
  - 2D Composite Component: a fixed or variable number of Reed-Solomon error correction codewords, depending upon the specific 2D Composite Component
- Character self-checking
- Bi-directionally decodable

### 5.8.1.2. Additional Features

The following is a summary of additional Composite Symbology features:

- Data compaction: The 2D Composite Components utilise a bit-oriented compaction mode designed to encode data efficiently using Application Identifiers (AIs).
- Component linkage: The 2D Composite Component of each Composite Symbol contains a linkage flag, which indicates to the reader that no data shall be transmitted unless the associated linear component is also scanned and decoded. All linear components except EAN/UPC Symbols also contain an explicit linkage flag.
- GS1-128 Symbol emulation: Readers set to the GS1-128 Symbol emulation mode transmit the data encoded within the Composite Symbol as if the data were encoded in one or more GS1-128 Symbols.
- A symbol Separator Character: A flag character to support future applications that instructs the reader to terminate transmission of the message at that point and to transmit the remaining data as a separate message
- 2D Composite Component escape mechanism: A mechanism to support future applications that require data content beyond the ISO/IEC 646 subset encodable in the standard form of the Composite Symbology

### 5.8.2. Symbol Structure

Each Composite Symbol consists of a linear component and a multi-row 2D Composite Component. The 2D Composite Component is printed above the linear component. The two components are separated by a separator pattern. Up to 3X of light space is permitted between the separator pattern and 2D Composite Component to facilitate printing the two components separately; however, if the two components are printed at one time, the nominal alignment should be followed as shown in Figure 5.8.2 - 1.

**Figure 5.8.2 - 1 GS1 DataBar Limited Composite Symbol with CC-A**



(01)13112345678906(17)010615(10)A123456

In Figure 5.8.2 - 1, the AI (01) Global Trade Item Number (GTIN) is encoded in the GS1 DataBar Limited (formerly RSS Limited) linear component. The AI (17) expiration date and the AI (10) lot number are encoded in the CC-A 2D Composite Component.

**The linear component is one of the following:**

- A member of the EAN/UPC Symbology (EAN-13, EAN-8, UPC-A, or UPC-E)
- A member of the GS1 DataBar (formerly RSS) family
- A GS1-128 Symbol

The choice of linear component determines the name of the Composite Symbol, such as an EAN-13 Composite Symbol, or a GS1-128 Composite Symbol.

The 2D Composite Component (abbreviated as CC) is chosen based on the selected linear component and on the amount of supplementary data to be encoded. The three 2D Composite Components, listed in order of increasing maximum data capacity, are:

- CC-A: a variant of MicroPDF417
- CC-B: a MicroPDF417 symbol with new encoding rules
- CC-C: a PDF417 symbol with new encoding rules

**Figure 5.8.2 - 2 GS1-128 Composite Symbol with CC-C**



(01)03812345678908(10)ABCD123456(410)3898765432108

In Figure 5.8.2 - 2, the AI (01) GTIN is encoded in the GS1-128 Symbol linear component. The AI (10) lot number and the AI (410) ship-to location are encoded in the CC-C 2D Composite Component.

Based upon the width of the linear component, a choice of “best-fit” 2D Composite Component is specified. Figure 5.8.2 - 3 lists all of the permissible combinations.

**Figure 5.8.2 - 3 Permissible Combinations of Linear and 2D Composite Components**

Linear Component	CC-A/CC-B	CC-C
UPC-A and EAN-13	Yes (4-columns)	No
EAN-8	Yes (3-columns)	No
UPC-E	Yes (2-columns)	No
GS1-128	Yes (4-columns)	Yes (variable width)
GS1 DataBar-14 and GS1 DataBar-14 Truncated	Yes (4-columns)	No
GS1 DataBar-14 Stacked and GS1 DataBar-14 Stacked Omnidirectional	Yes (2-columns)	No
GS1 DataBar Limited	Yes (3-columns)	No
GS1 DataBar Expanded and GS1 DataBar Expanded Stacked	Yes (4-columns)	No

### 5.8.2.1. CC-A Structure

CC-A is a variant of MicroPDF417 with a unique combination of row address patterns (RAP). It is the smallest of the 2D Composite Components and can encode up to 56 digits. It has from 3 to 12 rows and 2 to 4 columns.

Each row is a minimum of 2X high (where X is the width of a module, narrow bar, or space). A 1X high minimum separator pattern is positioned between the linear component and 2D Composite Component. (A different separator pattern, 6X high, is used in Composite Symbols with EAN/UPC linear components).

Each column contains one  $n,k = 17,4$  data or error correction character (codeword) per row (n is the number of modules, and k is the number of bars and also the number of spaces). So the width of a codeword is 17X.

In addition to the codeword columns, CC-A has two or three  $n,k = 10,3$  RAP columns that encode the row numbers (each 10X wide). The rightmost RAP column is terminated on the right by a 1X bar, so it is 11X instead of 10X wide.

Each row also requires a 1X Quiet Zone at each end. There is no Quiet Zone required above CC-A. The separator pattern is printed directly above the linear component and no Quiet Zone is required below the CC-A.

The two-column and three-column CC-A versions have two RAP columns, and the four-column CC-A version has three RAP columns, as shown in Figure 5.8.2.1 -1.

**Figure 5.8.2.1 - 1 CC-A Column Structures**

**Two-Column CC-A Structure**

Quiet Zone	RAP Column	Codeword Column	Codeword Column	RAP Column	Quiet Zone
------------	------------	-----------------	-----------------	------------	------------

**Three-Column CC-A Structure**

Quiet Zone	Codeword Column	RAP Column	Codeword Column	Codeword Column	RAP Column	Quiet Zone
------------	-----------------	------------	-----------------	-----------------	------------	------------

**Four-Column CC-A Structure**

Quiet Zone	RAP Column	Codeword Column	Codeword Column	RAP Column	Codeword Column	Codeword Column	RAP Column	Quiet Zone
------------	------------	-----------------	-----------------	------------	-----------------	-----------------	------------	------------

Figure 5.8.2.1 - 2 lists all possible column and row combinations for CC-A. It also shows the capacity and size of the 2D Composite Components. For example, a two-column, five-row CC-A would be 57X wide (including 1X for the extra right-most guard bar) by 10X high (not including the separator pattern). With an X-dimension of 0.25 millimetre (0.010 inch), it would be 14.25 millimetres (0.57 inch) wide by 2.50 millimetre (0.10 inch) high.

**Figure 5.8.2.1 - 2 CC-A Row and Column Sizes**

Number of Data Columns (c)	Number of Rows (r)	Total CWs in Data Region	Number of EC CWs (k)	Percent of CWs for EC	Number of CWs for Data	Max Alpha Chars	Max Digits	Component Width, in X (see Note 1)	Component Height, in X (see Note 2)
2	5	10	4	40.00%	6	8	16	57	10
2	6	12	4	33.33%	8	12	22	57	12
2	7	14	5	35.71%	9	13	24	57	14
2	8	16	5	31.25%	11	17	30	57	16
2	9	18	6	33.33%	12	18	33	57	18
2	10	20	6	30.00%	14	22	39	57	20
2	12	24	7	29.17%	17	26	47	57	24
3	4	12	4	33.33%	8	12	22	74	8
3	5	15	5	33.33%	10	15	27	74	10
3	6	18	6	33.33%	12	18	33	74	12
3	7	21	7	33.33%	14	22	39	74	14
3	8	24	7	29.17%	17	26	47	74	16
4	3	12	4	33.33%	8	12	22	101	6
4	4	16	5	31.25%	11	17	30	101	8
4	5	20	6	30.00%	14	22	39	101	10
4	6	24	7	29.17%	17	26	47	101	12
4	7	28	8	28.57%	20	31	56	101	14

CW = Codeword; EC = Error Correction

- Note:** Includes a 1X Quiet Zone on each side
- Note:** Assumes row height = 2X; does not include separator pattern

### 5.8.2.2. CC-B Structure

CC-B is a MicroPDF417 symbol uniquely identified by the codeword 920 as the first codeword in the symbol. Encoding systems normally automatically select CC-B when the data to be encoded exceeds the capacity of CC-A. CC-B can encode up to 338 digits. It has from 10 to 44 rows and 2 to 4 columns.

Each row is a minimum of 2X high (where X is the width of a module, narrow bar or space). A 1X high minimum separator pattern is positioned between the linear component and 2D Composite Component. (A different separator pattern, 6X high, is used in Composite Symbols with EAN/UPC linear components).

Each column contains one n,k = 17,4 data or error correction character (codeword) per row (where n is the number of modules, and k is the number of bars and also the number of spaces). So the width of a codeword is 17X.

In addition to the codeword columns, CC-B has two or three n,k = 10,3 row address pattern (RAP) columns that encode the row numbers (each 10X wide). The rightmost RAP column is terminated on the right by a 1X bar, so it is 11X instead of 10X wide.

Each row also requires a 1X Quiet Zone on each end. There is no Quiet Zone required above CC-B. The separator pattern is printed directly above the linear component, and no Quiet Zone is required below the CC-B.

The two-column CC-B version has two RAP columns and the three- and four-column CC-B versions have three RAP columns, as shown in Figure 5.8.2.2 - 1.

**Figure 5.8.2.2 – 1 CC-B Column Structures**

**Two-Column CC-B Structure**

Quiet Zone	RAP Column	Codeword Column	Codeword Column	RAP Column	Quiet Zone
------------	------------	-----------------	-----------------	------------	------------

**Three-Column CC-B Structure**

Quiet Zone	RAP Column	Codeword Column	RAP Column	Codeword Column	Codeword Column	RAP Column	Quiet Zone
------------	------------	-----------------	------------	-----------------	-----------------	------------	------------

**Four-Column CC-B Structure**

Quiet Zone	RAP Column	Codeword Column	Codeword Column	RAP Column	Codeword Column	Codeword Column	RAP Column	Quiet Zone
------------	------------	-----------------	-----------------	------------	-----------------	-----------------	------------	------------

CC-B differs from CC-A in the three-column structure in that CC-B has a third RAP column on the left end that is missing in CC-A.

Figure 5.8.2.2 - 2 lists all the possible column and row combinations for CC-B. It also shows the capacity and size of the 2D Composite Components. For example a four-column, 10-row CC-B would be 101X wide by 20X high (not including the separator pattern). With an X-dimension of 0.25 millimetre (0.010 inch), it would be 25.25 millimetres (1.01 inches) wide by 5.00 millimetres (0.20 inch) high.

**Figure 5.8.2.2 - 2 CC-B Row and Column Sizes**

Number of Data Columns (c)	Number of Rows (r)	Total CWs in Data Region	Number of EC CWs (k)	Percent of CWs for EC	Number of non-EC CWs	Number of CWs for Data (Note 1)	Max Alpha chars	Max Digits	CC-B Width, in X (see Note 2)	CC-B Height, in X (see Note 3)
2	17	34	10	29	24	22	34	59	57	34
2	20	40	11	28	29	27	42	73	57	40
2	23	46	13	28	33	31	48	84	57	46
2	26	52	15	29	37	35	55	96	57	52
3	15	45	21	47	24	22	34	59	84	30
3	20	60	26	43	34	32	50	86	84	40

Number of Data Columns (c)	Number of Rows (r)	Total CWs in Data Region	Number of EC CWs (k)	Percent of CWs for EC	Number of non-EC CWs	Number of CWs for Data (Note 1)	Max Alpha chars	Max Digits	CC-B Width, in X (see Note 2)	CC-B Height, in X (see Note 3)
3	26	78	32	41	46	44	68	118	84	52
3	32	96	38	40	58	56	88	153	84	64
3	38	114	44	39	70	68	107	185	84	76
3	44	132	50	38	82	80	127	219	84	88
4	10	40	16	40	24	22	34	59	101	20
4	12	48	18	38	30	28	43	75	101	24
4	15	60	21	35	39	37	58	100	101	30
4	20	80	26	33	54	52	82	141	101	40
4	26	104	32	31	72	70	111	192	101	52
4	32	128	38	30	90	88	139	240	101	64
4	38	152	44	29	108	106	168	290	101	76
4	44	176	50	28	126	124	196	338	101	88

CW = Codeword; EC = Error correction

- Note:** Excludes EC codewords and 2 codewords to define CC-B encodation
- Note:** Including 1X Quiet Zones on either side
- Note:** Assumes  $Y = 2X$ ; does not include separator pattern

### 5.8.2.3. CC-C Structure

CC-C is a PDF417 symbol uniquely identified by the codeword 920 as the first codeword in the symbol following the symbol length descriptor. CC-C can be used as a 2D Composite Component within a GS1-128 Composite Symbol. It has the greatest data capacity of the Composite Symbols, encoding up to 2,361 digits. It has from 3 to 30 rows and 1 to 30 data/EC codeword columns.

Each row is a minimum of 3X high (where X is the width of a module, narrow bar, or space). A 1X high minimum separator pattern is positioned between the linear component and 2D Composite Component.

Each column contains one  $n, k = 17, 4$  data or error correction character (codeword) per row (where n is the number of modules, and k is the number of bars and also the number of spaces). So the width of a data/EC codeword is 17X.

In addition to the codeword columns, CC-C has two 17,4 row indicator columns, a 17X wide start pattern, and a 18X wide stop pattern as illustrated in Figure 5.8.2.3 - 1.

Each row also requires a 2X Quiet Zone on each end. There is no Quiet Zone required above CC-C. The separator pattern is printed directly above the linear component, and no Quiet Zone is required below the CC-C.

Figure 5.8.2.3 - 1 CC-C Row Structure

Quiet Zone	Start Pattern	Left Row Indicator Column	1 to 30 Data/EC Codeword Columns	Right Row Indicator Column	Stop Pattern	Quiet Zone
------------	---------------	---------------------------	----------------------------------	----------------------------	--------------	------------

CC-C is normally printed with the number of columns that will result in a width nearly matching the width of the GS1-128 Symbol linear component. However, as an option, the user may specify a wider CC-C to be printed. This reduces the height of the 2D Composite Component. A lower Composite Symbol may be needed to fit in a height-restricted application. A wider CC-C may also be required if the amount of data does not fit in the default width CC-C.

#### 5.8.2.4. Special Compressed Element String Sequences

While 2D Composite Components can encode any sequence of Application Identifier (AI) Element Strings up to the maximum capacity of the component, certain sequences of AI Element Strings have been selected for special compression in 2D Composite Component Symbols. If the application requires the use of the AI Element Strings in one of these sequences, and they are used in the predefined sequence, a smaller symbol will result.

For special compression to be performed, the AI Element String sequence must occur at the start of the 2D Composite Component's data. Other AI Element Strings may be added following the sequence.

The AI Element Strings selected for special compression are:


- Production date and lot number: AI (11) production date followed by AI (10) lot number
- Expiration date and lot number: AI (17) expiration date followed by AI (10) lot number
- AI (90): AI (90) followed by the Element String data starting with an alphabetic character and a digit; AI (90) may be used to encode data identifier data; the AI (90) followed by data in the data identifier format has special compression applied only if it is the start of the first Element String.

#### 5.8.3. Human Readable Interpretation of Composite Symbols

The Human Readable Interpretation of the linear component of the Composite Symbol must be shown below the linear component. If there is a Human Readable Interpretation of the 2D Composite Component, there is no required location, but it should be close to the Composite Symbol.

The precise location of the human readable characters and the font used to represent them are not specified for Composite Symbols. However, the characters should be clearly legible (such as OCR-B) and must be obviously associated with the symbol.

Application Identifiers (AIs) should be clearly recognisable to facilitate key entry. This is achieved by putting the AI between parentheses in the Human Readable Interpretation.

 **Note:** The parentheses are not part of the data and are not encoded in the bar code symbol, following exactly the same principle that applies to GS1-128 Symbols.

As an option, the data title (see Section 3.2) may be associated with the data instead of using AIs. Figure 5.8.3 - 1 shows the expiration date and lot number identified with text. This can be compared with Figure 5.8.2 - 1, where the same data is shown using the all-AI format.

**Figure 5.8.3 - 1 The Human Readable Interpretation**

For Composite Symbols encoding a large amount of data, it may not be practical to display all the data in Human Readable Interpretation form or, even if there is space to show it in this form, it may not be practical to key enter that much data. In these instances, some of the data may be omitted from the Human Readable Interpretation. However, primary identification data such as the Global Trade Item Number (GTIN) and SSCC must always be shown. Application specifications provide guidance on Human Readable Interpretation.

## 5.8.4. Data Transmission and Symbology Identifier Prefixes

### 5.8.4.1. Default Transmission Mode

The GS1 System requires the use of symbology identifiers. Composite Symbols are normally transmitted using symbology identifier prefix “je0,” with the data from the 2D Composite Component directly appended to that of the linear component. For example, a Composite Symbol encoding (01)10012345678902(10)ABC123 produces the data string “je0011001234567890210ABC123” (note that the symbology identifier prefix “je0” is different from the symbology identifier prefix “JE0,” which has an uppercase “E” and is used for standard EAN/UPC Symbols). However, readers have an option to transmit only the linear component data and ignore the 2D Composite Component.

Data transmission follows the same principles that apply to the concatenation of Application Identifier (AI) Element Strings from GS1-128 Symbols. If the linear component data ends with a variable length AI Element String, an ASCII 29 character (GS) is inserted between it and the first character of the data from the 2D Composite Component.

### 5.8.4.2. GS1-128 Symbol Transmission Mode

Readers also have an option for GS1-128 Symbol emulation mode. This mode emulates the GS1-128 Symbology for data transmission. It can be used for applications programmed for GS1-128 Symbols but not yet programmed to recognise the symbology identifier prefix “je0.” The symbology identifier for GS1-128 Symbol emulation mode is “jC1.” Composite Symbols that exceed 48 data characters are transmitted as two or more messages so as not to exceed the maximum GS1-128 Symbol message length. Each of the messages has a symbology identifier prefix of “jC1” and does not exceed 48 data characters. The messages are split at boundaries between Element Strings. This mode is inferior to the normal transmission mode as message integrity may be lost when a message is split into multiple messages.

### 5.8.4.3. Symbol Separator Character

The 2D Composite Component can encode symbol Separator Characters as defined in the decoder. This character instructs the reader to terminate the current Composite Symbol’s data message and transmit the data following the symbol separator as a separate message. This new message will have

the symbology identifier prefix of “je1.” This feature will be used for future GS1 System applications such as encoding the mixed contents of a logistical container.

#### 5.8.4.4. 2D Composite Component Escape Mechanism

The CC-B and CC-C also can encode 2D Composite Component escape mechanism codewords. These instruct the reader to terminate the current Composite Symbol's data message and transmit the data following the escape mechanism codeword as a separate message. This new message has the symbology identifier prefix of “je2” for standard data message or “je3” if the data message includes an ECI codeword. The codewords following the escape mechanism codeword are encoded and decoded using the standard PDF417 encoding defined in *ISO/IEC 15438 – Information technology; automatic identification and data capture techniques - Symbology specification - PDF417*. This feature is used for future GS1 System applications that require characters beyond the ISO/IEC 646 character subset defined for Application Identifier (AI) Element String data.

#### 5.8.5. Width of a Module (X)

The X-dimension of the 2D Composite Component must be the same as that of the associated linear component. Refer to the linear component's X-dimension requirements.

#### 5.8.6. Print Quality

The print quality assessment methodology defined in the International Standard *ISO/IEC 15416* should be used for measuring and grading the linear components. The ISO print quality specification is functionally identical to the older ANSI and CEN print quality specifications. The print quality grade is measured by verifiers that apply the standard. The print quality grade reported includes a grade level, measuring aperture, and the wavelength of light used for the measurement.

AIM ITS 99-002 – International Symbology Specification - MicroPDF417 and ISO/IEC 15438 specify the methods for determining the print quality grade of the 2D Composite Components CC-A/B and CC-C respectively. An additional grading parameter unused error correction (UEC) is defined in these specifications.


The minimum quality grade for Composite Symbols is:

**1.5 / 6 / 670**

- Where-

- 1.5 is the overall symbol quality grade.
- 6 is the measuring aperture reference number (corresponding to an 0.15 millimetre or 0.006 inch diameter aperture).
- 670 is the peak response wavelength in nanometres. In addition to the print quality grade, all elements in the separator patterns should be visually distinguishable.

Both the linear component and the 2D Composite Component must independently achieve the minimum print quality grade.

 **Note:** An international standard methodology for quality grading two-dimensional symbologies is under development and may eventually supersede the method defined in the above specifications.

#### 5.8.7. Advice for Selecting a Symbology

Any use of the 2D Composite Component should comply with GS1 System global application guidelines. The linear component of a Composite Symbol should be selected according to the

application rules defined in these *GS1 General Specifications*, but where a choice of linear components is available for the application, consideration should also be given to the 2D Composite Component options available. A wider linear component will result in a shorter 2D Composite Component and, particularly for CC-B, a higher capacity symbol.

For CC-A and CC-B, the selection of the linear component automatically determines the number of columns of the 2D Composite Component. The selection of CC-A or CC-B is automatically determined by the amount of data to be encoded. CC-A is always used unless the data exceeds its capacity.

When the linear component is a GS1-128 Symbol, the user may specify CC-A/B or CC-C. CC-A/B will produce a smaller 2D Composite Component. However, CC-C can increase in width to match the width of the GS1-128 Symbol or be selected to be even wider. This may produce a Composite Symbol of lower height. CC-C also has a larger data capacity, so it is suitable for applications such as logistics.

### 5.8.8. Sample Composite Symbols

Figure 5.8.8 - 1 EAN-13 Symbol with a Four-Column CC-A Component



Figure 5.8.8 - 2 UPC-A Symbol with a Four-Column CC-B Component



Figure 5.8.8 - 3 EAN-8 Symbol with a Three-Column CC-A



Figure 5.8.8 - 4 UPC-E Symbol with a Two-Column CC-A



Figure 5.8.8 - 5 GS1 DataBar-14 Symbol with a Four-Column CC-A



Figure 5.8.8 - 6 GS1 DataBar-14 Stacked Symbol with a Two-Column CC-A



**Figure 5.8.8 - 7 GS1 DataBar Limited Symbol with a Three-Column CC-B**



(01)03512345678907



**Note:** The three-column CC-B is wider than the three-column CC-A shown in Figure 5.8.2 - 1.

**Figure 5.8.8 - 8 GS1 DataBar Expanded Symbol with a Four-Column CC-A**



(01)93712345678904(3103)001234

(91)1A2B3C4D5E

**Figure 5.8.8 - 9 GS1-128 Symbol with a Four-Column CC-A**



(01)03212345678906

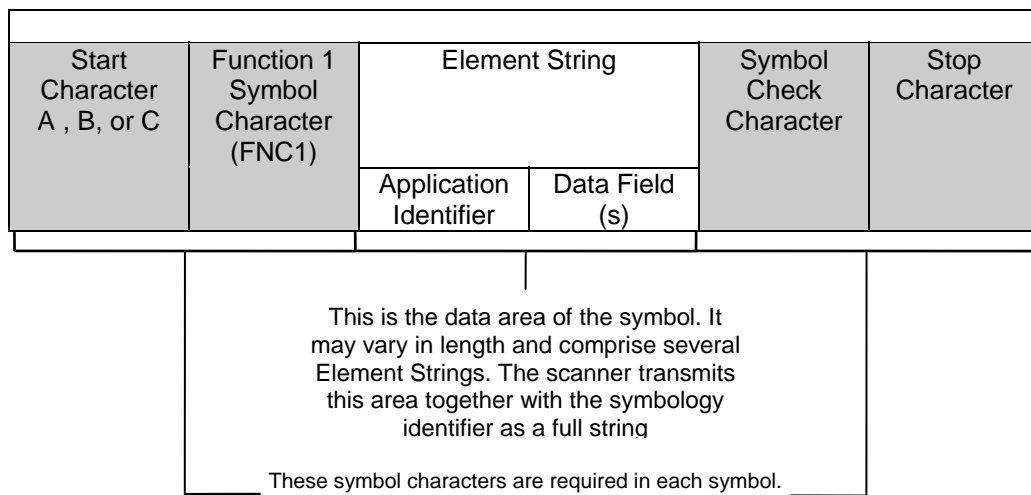
(21)A1B2C3D4E5F6G7H8

## 5.9. Appendix: Rules for Encoding/Decoding Element Strings in GS1 Symbologies using GS1 Application Identifiers

### 5.9.1. The Basic Structure of GS1 Bar Code Symbols using GS1 Application Identifiers and Concatenation

All GS1 bar code symbologies that use GS1 Application Identifiers have a particular symbol characters to indicate that the data is encoded according to the GS1 Application Identifier rules. For example the GS1-128 Symbology uses the Function 1 Symbol Character (FNC1) in the position following the Start Character. This double start pattern is reserved for GS1 System applications worldwide. This makes it possible to distinguish GS1-128 Bar Code Symbols from extraneous non-GS1 bar code symbols.

**Figure A1 - 1 Example GS1-128 Bar Code Symbol Structure**



All GS1 bar code symbologies that use GS1 Application Identifiers allow several Element Strings to be encoded in one bar code symbol, a process called concatenation. Concatenation is advantageous because it means that the symbology elements are only needed once, and the space required for the symbol is smaller than when separate bar code symbols are used to encode each Element String. It also improves scanning accuracy, allowing for single scanning rather than multiple scanning. The various Element Strings can be transmitted from the bar code reader as a single full string.

The various Element Strings, which are transmitted from concatenated bar code symbols, have to be analysed and processed. To simplify this procedure and reduce the symbol size, the lengths of some Element Strings are pre-defined (see Figure A1 -2). Element Strings that are not contained in Figure A1 - 2 and that do not appear at the end of the symbol (encoded immediately before the Symbol Check Character) must immediately be followed by an FNC1 to separate it from the Element String that follows.

Figure A1 - 2 contains all Application Identifiers that have a predefined length and, therefore, do not require a Function 1 Symbol Character (FNC1) separator.

**Figure A1 - 2 Element Strings with Pre-Defined Length Using Application Identifiers**

First Two Digits of the Application Identifier	Number of Characters (Application Identifier and Data Field)	First Two Digits of the Application Identifier	Number of Characters (Application Identifier and Data Field)
00	20	17	8
01	16	(18)	8
02	16	(19)	8
(03)	16	20	4
(04)	18	31	10
11	8	32	10
12	8	33	10
13	8	34	10
(14)	8	35	10
15	8	36	10
(16)	8	41	16

**Note:** Figure A1 - 2 is limited to the listed numbers and will remain unchanged. Those numbers in parentheses are not yet assigned. Application Identifiers starting with two digits that are not included in Figure A1 - 2 have a variable length even if the definition of the Application Identifier specifies a fixed length data field.

### 5.9.2. Concatenation of the Pre-Defined Length Element Strings

Concatenated Element Strings constructed from Application Identifiers with a pre-defined length do not require a Separator Character. Each Element String is immediately followed by either the next Application Identifier or the Symbol Check Character and Stop Character.

For example, concatenation of net weight (4.00 kilograms) with the associated Global Trade Item Number (GTIN) 95012345678903 does not require the use of a Separator Character.

- (01) has a pre-defined Element String length of 16 digits.
- (31) has a pre-defined Element String length of 10 digits.

**Figure A.1.1 – 1 Data Encoded in two GS1-128 symbols**



**Figure A.1.1 – 2 Data Encoded in one Concatenated GS1-128 symbol**



**5.9.2.1. Variable Length Data Strings**

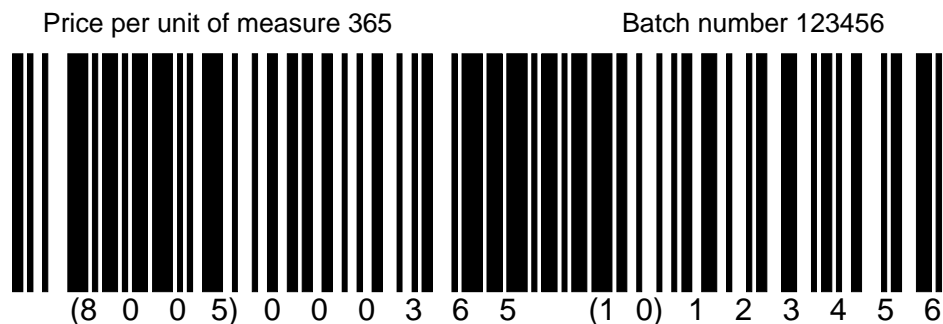
Concatenating Element Strings of variable length, including all Application Identifiers that do not start with two characters contained in Figure A1 - 2, involves the use of a Separator Character. The Separator Character used is the Function 1 Symbol Character (FNC1). It is placed immediately after the last symbol character of a variable length data string and is followed by the Application Identifier of the next Element String. If the Element String is the last to be encoded, it is followed by the Symbol Check and Stop Characters and not the FNC1 Separator Character.

For example, concatenation of price per unit of measure (365 currency units) and batch number (123456) requires the use of a Separator Character immediately after the price per unit of measure.

**Figure A1.2 – 1 Data Encoded in two GS1-128 symbols**



**Figure A1.2 - 2 Data Encoded in one Concatenated GS1-128 symbol**



**Note:** The FNC1 is not shown in Human Readable Interpretation.

### 5.9.2.2. Other considerations when using Concatenation

Concatenation is an effective means for presenting multiple Element Strings in a single bar code symbol and should be used to conserve label space and optimise scanning operations when permitted by the application guideline (e.g., concatenation shall not be used with the GS1-128 bar code symbol containing the SSCC on cartons or outer-cases).

When concatenating a mixture of pre-defined and other Element Strings, the pre-defined Element Strings should appear before the variable length Element Strings.

The FNC1 Separator Character appears in the decoded data string as <GS> (ASCII character 29, 7-bit character set ISO/IEC 646). A FNC1 is not required at the end of the last Element String represented in a GS1 Symbologies using GS1 Application Identifiers. The processing routine allows for a FNC1 entered by error after an Element String contained in Figure A1 - 2.

**Figure A1.3 - 1 Example of GS1 DataBar Expanded Stacked Bar Code Symbol that uses concatenation**



Concatenation may not be desirable in all circumstances (e.g., GS1 Logistic Labels are often constructed using multiple rows of bar code), in such cases the bar code containing the additional attribute data encoded using GS1 Application Identifiers should be printed in close proximity to the bar code containing the GS1 Identification Key.

**Figure A1.3 - 2 Example of mixed GS1 Symbologies (GTIN encoded in UPC-E, Best Before Date in Composite)**





## Section 6. Symbol Placement Guidelines

- Introduction
- General Placement Principles
- General Placement Guidelines for Point-of-Sale
- Placement Guidelines for Specific Package Types
- Symbol Placement for Clothing and Fashion Accessories
- Plastic Packaged Products Label Location Guidelines
- GS1 Logistics Label Design
- Placement Labels Used in General Distribution

Whilst every effort has been made to ensure that the guidelines to use the GS1 standards contained in the document are correct, GS1 and any other party involved in the creation of the document HEREBY STATE that the document is provided without warranty, either expressed or implied, of accuracy or fitness for purpose, AND HEREBY DISCLAIM any liability, direct or indirect, for damages or loss relating to the use of the document. The document may be modified, subject to developments in technology, changes to the standards, or new legal requirements.

Several products and company names mentioned herein may be trademarks and/or registered trademarks of their respective companies.


## 6.1. Introduction

This section includes guidelines for the placement of bar code symbols on packages and containers. It gives the general principles that apply, mandatory rules, and recommendations for symbol placement on specific packaging and container types.

Consistency of symbol placement is critical to successful scanning. With manual scanning, variation of symbol placement makes it difficult for the scanning operator to predict where the symbol is located, and this reduces efficiency. With automated scanning, the symbol must be positioned so that it will pass through the field of vision of a fixed scanner as it travels past. Respecting the guidance in this section will result in the consistency and predictability required.

The guidelines in this global specification replace previous local recommendations; however, manufacturers should not scrap packaging that has been printed according to previous guidelines. When packaging is redesigned, the global specifications in this document should be observed.

If government regulatory guidelines are inconsistent with those in this manual, the government guidelines should always take precedence.

 **Note:** Bar code symbols in this guideline that are used as examples are For Position Only and are not intended to denote correct symbol type, size, colour, or quality.

## 6.2. General Placement Principles

The following general principles for bar code symbol placement should be considered for any package type, whether it is scanned at the Point-of-Sale or elsewhere in the supply chain. Trade items intended to be scanned at a Point-of-Sale must be marked with an EAN-13, UPC-A, EAN-8, or UPC-E Bar Code Symbol. The bar code symbols that are scanned elsewhere are the EAN-13, UPC-A, ITF-14, and GS1-128 Bar Code Symbols.

EAN-8 and UPC-E Bar Code Symbols are intended for use on very small trade items sold at the Point-of-Sale. GS1 DataBar Symbols (formerly RSS) will follow the placement principles when available for use in 2010.

### 6.2.1. Number of Symbols

Bar code symbols representing different Global Trade Item Numbers (GTINs) must never be visible on any one item. Although a minimum of one symbol is required, two symbols representing the same GTIN are recommended on trade items for scanning in warehousing or General Distribution Scanning environments (see Section [6.8](#)). Two or more symbols representing the same GTIN are recommended on large, heavy, or bulky items for Point-of-Sale (see Section [6.4.9](#)) and are permissible on random wraps intended for Point-of-Sale (see Section [6.3.3.7](#)).

### 6.2.2. Scanning Environment

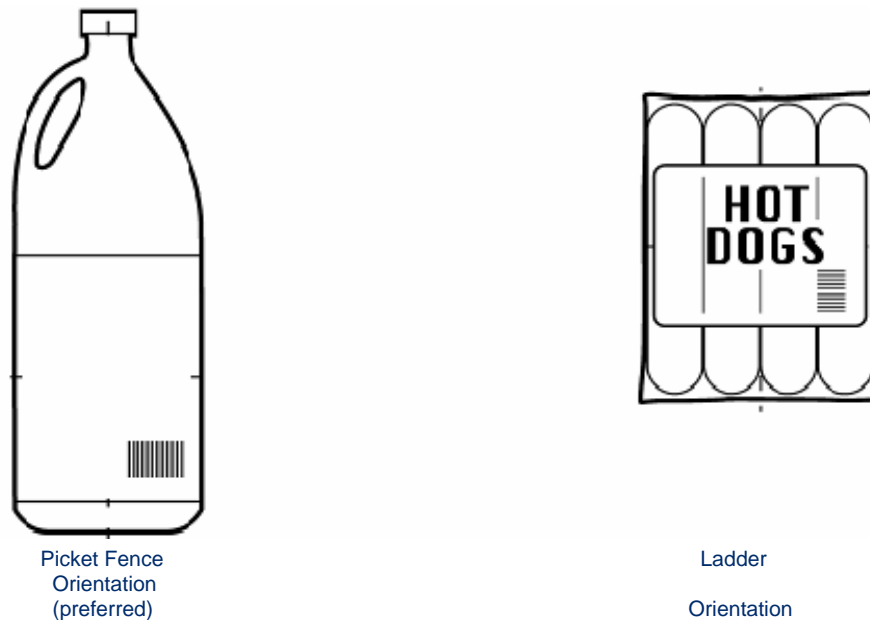
Before considering the package type, determine whether the item will be scanned in a Point-of-Sale or a General Distribution Scanning environment. If the item is scanned at a Point-of-Sale only, the bar code symbol placement guidelines in Sections [6.3](#), [6.4](#), and [6.5](#), and [6.6](#) apply. However, if the item is scanned in both a Point-of-Sale and General Distribution Scanning environment or in a General Distribution Scanning environment only, the requirements (see Section [6.8](#)) take precedence.

### 6.2.3. Orientation

Bar code symbol orientation is determined primarily by the print process and any curvature of the item. If the printing process and curvature allow, the preferred placement is picket fence orientation, in

which the bars of the bar code symbol are perpendicular to the surface on which the package stands in its normal display position. With picket fence orientation, the Human Readable Interpretation beneath the symbol reads from left to right. The text and orientation in a ladder orientation symbol can be read either from the top down, or from the bottom up, whichever is consistent with other text and graphics on the container. Empirical data has demonstrated that it makes no difference to the scanning process one way or the other. Rules for positioning bar code symbols on curved surfaces are given in Section [6.2.3.2](#).

Figure 6.2.3 - 1



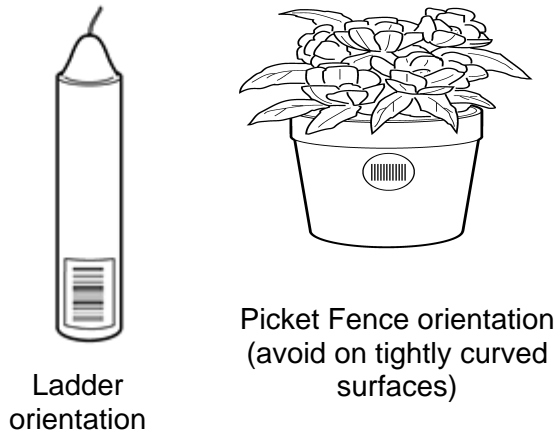
### 6.2.3.1. Printing Direction

Bar code orientation is often determined by the printing process. Some printing processes give much higher quality results if the bars of the symbol run in the direction of the print, also known as the web direction. The printing company should always be consulted.

### 6.2.3.2. Trade Items with Curved Surfaces

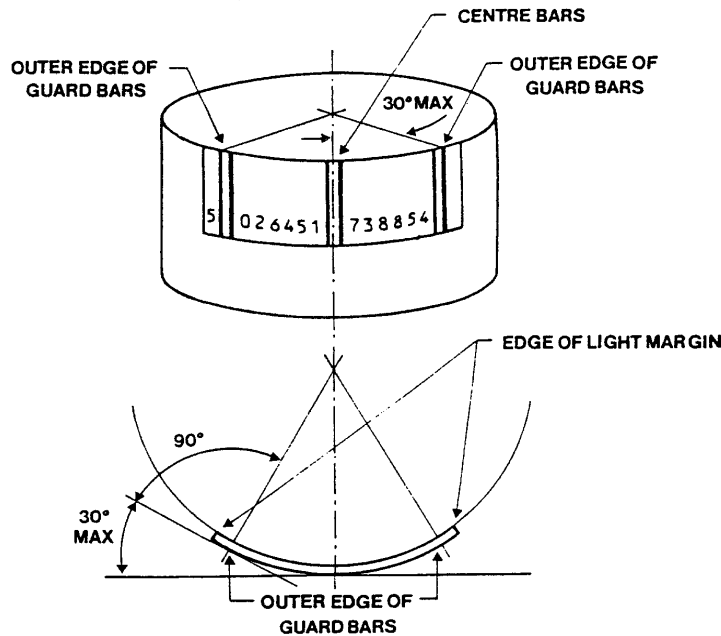
When a bar code symbol is printed onto a curved surface it is sometimes possible for the extremes of the symbol to disappear around the curve, so that both ends cannot be visible to the scanner at the same time. This is more likely to occur the bigger the symbol and the tighter the curve of the packaging. In these situations, bars must be printed using certain combinations of the X-dimension and diameter of the curved surface (e.g., in ladder orientation on a can, in picket fence orientation on a cylindrical packet of biscuits). This helps ensure that the curve results in an apparent loss of height of the bars rather than the more serious apparent loss of complete bars.

**Figure 6.2.3.2 - 1 Bar Code Symbol Placement on Curved Surfaces**



The angle between the tangent to the centre of the curved symbol and the tangent to the extremity of the curved symbol (outer edge of the guard bars for symbols in the EAN/UPC Symbology) must be less than 30 degrees. If this angle is more than 30 degrees, the symbol must be oriented such that the bars are perpendicular to the generating lines of the surface of the item.

**Figure 6.2.3.2 – 2 Relationship Between Symbol and Curvature**



Figures 6.2.3.2 - 3 and 6.2.3.2 - 4 show the relationship between acceptable X-dimensions (narrow element width) for units of different diameters and the minimum diameters for different X-dimensions for bar code symbols printed in the picket fence orientation. Please refer to Section 5.5 for the minimum, target, and maximum X-dimension for the symbol, based on the scanning environment.

Figure 6.2.3.2 – 3

Diameter of Container		Maximum Value of X-Dimension			
		EAN-13 or UPC-A Bar Code Symbol		EAN-8 Bar Code Symbol	
mm	Inches	mm	Inches	mm	Inches
30 or below	1.18 or below	*	*	*	*
35	1.38	*	*	<i>(0.274)</i>	<i>(0.0108)</i>
40	1.57	*	*	<i>(0.314)</i>	<i>(0.0124)</i>
45	1.77	*	*	0.353	0.0139
50	1.97	<i>(0.274)</i>	<i>(0.0108)</i>	0.389	0.0153
55	2.16	<i>(0.304)</i>	<i>(0.0120)</i>	0.429	0.0169
60	2.36	0.330	0.0130	0.469	0.0185
65	2.56	0.356	0.0140	0.508	0.0200
70	2.75	0.386	0.0152	0.549	0.0216
75	2.95	0.413	0.0163	0.587	0.0232
80	3.25	0.446	0.0174	0.627	0.0247
85	3.35	0.469	0.0185	0.660	0.0260
90	3.54	0.495	0.0195	0.660	0.0260
95	3.74	0.525	0.0207	0.660	0.0260
100	3.94	0.551	0.0217	0.660	0.0260
105	4.13	0.578	0.0228	N/A	N/A
110	4.33	0.607	0.0239	N/A	N/A
115	4.53	0.634	0.0250	N/A	N/A
120 or above	4.72	0.660	0.0260	N/A	N/A

- Note:** An asterisk (\*) indicates that the package diameter is too small to permit a picket fence orientation bar code symbol, and the symbol must be rotated 90 degrees to a ladder orientation (see Section 5.5) The bar code symbol is printed perpendicular to the generating lines of the surface of the container.
  
- Note:** *Italics* indicate X-dimensions that are permissible, but are not recommended on curved surfaces.
  
- Note:** EAN-8 Bar Code Symbols reserved for very small items (See Section 2.1.).

**Figure 6.2.3.2 – 4 Relationship Between the X-Dimension and Diameter**

X-Dimension		Minimum Diameter of Container					
		EAN-13 or UPC-A Bar Code Symbol		EAN-8 Bar Code Symbol		UPC-E Bar Code Symbol	
mm	inches	mm	inches	mm	inches	mm	inches
0.264	0.0104	48	1.33	34	1.89	26	1.01
0.300	0.0118	55	1.51	38	2.14	29	1.51
0.350	0.0138	64	1.76	45	2.50	34	1.53
0.400	0.0157	73	2.02	51	2.86	39	1.54
0.450	0.0177	82	2.27	58	3.21	44	1.73
0.500	0.0197	91	2.52	64	3.57	49	1.92
0.550	0.0217	100	2.77	70	3.93	54	2.11
0.600	0.0236	109	3.02	77	4.29	59	2.31
0.650	0.0256	118	3.27	83	4.64	63	2.50
0.660	0.0260	120	3.35	85	4.72	64	2.54

### 6.2.3.3. Avoiding Scanning Obstacles

Anything that will obscure or damage a bar code symbol will reduce scanning performance and should be avoided. For example:

- Never position the bar code symbol on the item in an area with inadequate space. Do not let the other graphics encroach on the space for the bar code.
- Never place bar code symbols, including Quiet Zones, on perforations, die-cuts, seams, ridges, edges, tight curves, folds, flaps, overlaps, and rough textures.
- Never put staples through a bar code symbol or its Quiet Zones.
- Never fold a symbol around a corner.
- Never place a symbol under a package flap.

## 6.3. General Placement Guidelines for Point-of-Sale

This section outlines the guidelines for bar code symbol placement on trade items that will be scanned at the Point-of-Sale. For detailed information on specific package types, see Sections [6.4](#), [6.5](#), and [6.6](#). Section [6.8](#) outlines guidelines for bar code symbol placement on trade items that will be scanned in warehousing or General Distribution Scanning environments. GS1 DataBar Symbols (formerly RSS) will follow the placement principles when available for use in 2010.

### 6.3.1. Number of Symbols

At least one bar code symbol is needed on a trade item intended for the Point-of-Sale. Exceptions include large, heavy, or bulky items (see Section [6.4.9](#)) and random or unregistered wrapping (see Sections [6.3.3.7](#)) where two or more symbols with the same Global Trade Item Number (GTIN) may be required.

Trade items should never have two or more bar code symbols encoding different Global Trade Item Numbers (GTINs). At the Point-of-Sale, this is particularly relevant with multipacks, such as over-wrapped items, sleeved items, and banded items, where the individual inner units carry a different GTIN from that on the outer wrapper or container. The bar code symbols on the inner products must be totally obscured so that they cannot be read by the Point-of-Sale system. (see Section [6.3.3.7](#) for over-wrap special considerations.)

### 6.3.2. Identifying the Back of the Trade Item

The front of the trade item is the primary trading/advertising area, which typically displays the product name and the company's logo. The back of the trade item is directly opposite the front and is the preferred placement area for the bar code symbol on most trade items.

### 6.3.3. Symbol Placement

Information in this section is provided to guide symbol placement when developing packaging for new products and should be adopted if economically feasible when changing the graphics of existing products.

#### 6.3.3.1. Preferred Placement

Preferred bar code symbol placement is on the lower right quadrant of the back, respecting the proper Quiet Zone areas around the bar code symbol and the edge rule (see the Edge Rule in Section [6.3.3.3](#) and special considerations in Section [6.3.3.7](#)).

#### 6.3.3.2. Undesirable Alternative

The undesirable alternative placement for a bar code symbol is the lower right quadrant of a side of the container other than the back.

#### 6.3.3.3. Edge Rule

When possible, the bar code symbol must not be closer than 8 mm (0.3 in.) or farther than 100 mm (4 inch) from the nearest edge of the package/container. Previous guidelines suggested a distance of 5 millimetres (0.2 inch) as a minimum. Practical experience has shown this to be inadequate. For example, cashiers often grab the edges of bags and other trade items with their thumbs. Avoid placing the bar code symbol too close to the edge. Such placement reduces efficiency at the Point-of-Sale.

#### 6.3.3.4. Avoid Truncated Symbols

Truncation of a bar code symbol is the reduction of the height of a bar code symbol relative to its length. Truncation is not recommended because it destroys the ability of a symbol to be scanned omnidirectionally at the Point-of-Sale. A truncated symbol can only be scanned when the trade item is oriented in particular directions across the scanning beam. Truncation, therefore, reduces checkout efficiency. The more the height of the symbol is reduced, the more critical becomes the alignment of the symbol across the scanning beam. Truncation should be avoided unless absolutely necessary (e.g., when printing on a tightly curved surface), and then the maximum height possible should be printed. See Section [6.2.3.2](#) for rules on the relationship between the diameter of the item and the X-dimension.

#### 6.3.3.5. Bottom Marking

Bottom marking of the trade item with the bar code symbol continues to be acceptable, except for large, heavy, or bulky trade items. However, back (side) marking is preferred.

#### 6.3.3.6. Exceptions to the General Placement Guidelines

Some trade items require special considerations for bar code symbol placement.

- Bags

When bag contents settle, the bag edges can bulge to the extent that bar code symbols located on the lower right quadrant may not be flat enough to permit successful scanning. For this reason, bar code

symbols on bags should be placed in the centre of the back about one third up from the bottom and as far from the edge as possible while respecting the edge rule. (See Section [6.4.1](#) for more details on bags.)

- Blister packs or unpackaged items

Trade items that cause scanners to read beyond the flat plane include blister packs and unpackaged items (e.g., deep bowls). For these items, the distance between the scanner window and the bar code symbol on the container or item must be considered. The bar code symbol cannot be closer than 8 millimetres (0.3 inch) or farther than 100 millimetres (4 inches) from any edge of the package/container. (See Sections [6.4.2](#) and [6.4.16](#) for more details on blister packs and unpackaged items.)

- Large, heavy, or bulky items

Any package/container weighing more than 13 kilograms (28 pounds) or having two dimensions greater than 450 millimetres (18 inches) (width/height, width/depth, or height/depth) is considered a large, heavy, or bulky item. Large, heavy, or bulky items tend to be hard to handle. Large bags require two symbols, one on top and one on the bottom of opposite quadrants of the bag. Large, heavy, or bulky bottles, boxes, cans, jars, jugs, and tubs require only one label. (See Section [6.4.9](#) for more details on large, heavy, or bulky items.)

- Thin items or containers

Thin items or containers are packages/containers with a dimension less than 25 millimetres (1 inch) (height, width, or depth). Examples of thin items or containers are packages of pizza, powdered drink mixes, and writing pads. Any placement of the symbol on the edge hinders effective scanning because the symbol is obscured from the cashier and is likely to be truncated. (Refer to Section [6.4.12](#) for more details on thin items or containers.)

### 6.3.3.7. Special Packaging Considerations for Bar Code Placement

Some packaging methods require special considerations for bar code symbol placement.

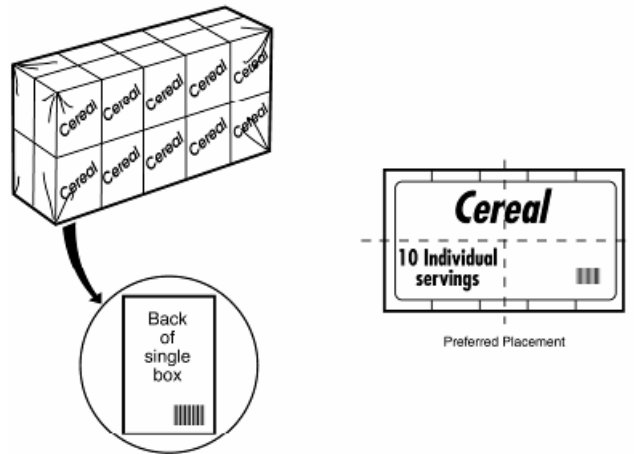
#### Over-wrap

Trade items sold in multiples are mechanically gathered and covered with clear over-wrap material that will carry print. Typical over-wrapped items are small cereal boxes and chocolate bars. Package over-wrap can create two distinct problems:

- Obscuring the bar code symbols on individual units inside the multipack is necessary so they are not confused with the outer multipack bar code symbol, which must be different.
- Over-wrapping with such materials as cellophane causes diffraction or reflection of the light beam of the scanner and can reduce contrast, which causes scanning inefficiencies.

To determine proper bar code symbol placement for over-wrapped packaging, follow the guidelines specific to the applicable package type/shape. (See Section [6.4](#) for details on symbol placement for specific package types.)

**Figure 6.3.3.7 - 1 Bar Code Symbol Placement on Over-Wrapped Item**



**Random (Unregistered) Wrap**

Some wrappers, like those used on sandpaper or margarine, have a repeating design and are neither cut nor placed on the product such that a particular part of the design always appears in the same location. This is referred to as random or unregistered wrapping. As the wrapper is not registered, it is unlikely that the symbol will appear on one face of the package when the wrapper is placed on the product.

The presence of more than one bar code symbol on a package can have a detrimental effect on scanning productivity and, more importantly, can lead to a double read. For this reason, the use of registered packaging is preferred. If random wrap must be used, the minimum requirement is to print the symbol with sufficient frequency so that a full symbol will appear on one package face.

Double reads are more likely when the gaps between the symbols are larger. Repeating symbols should never be more than 150 millimetres (6 inches) apart.

Consideration should also be given to elongating the bars of the symbol to ensure a full symbol on one face, instead of repeating the symbol.

**Figure 6.3.3.7 - 2 Bar Code Symbol Placement on Random-Wrapped Item**

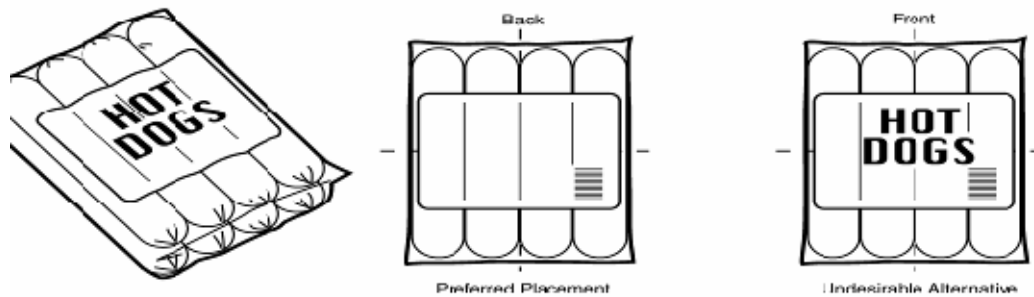


### Shrink film/vacuum-formed packages

The bar code symbol on an item packaged in shrink film or that is vacuum-formed should be located on a flat surface and in an area free of creases, wrinkles, or other types of distortions. Refer to Figure 6.3.3.7 – 3, which shows bar code symbol placement on hot dogs. Since the curvature of the hot dogs was greater than the diameter shown within the Section 6.2.3.2 figures, a ladder orientation symbol was used.

To determine proper bar code symbol placement for shrink film/vacuum-formed packaging, follow the guidelines specific to the applicable package type/shape. (Refer to Section 6.4 for details on symbol placement for specific package types/shapes.)

Figure 6.3.3.7 – 3 Bar Code Symbol Placement on Shrink Film/Vacuum-Formed Item



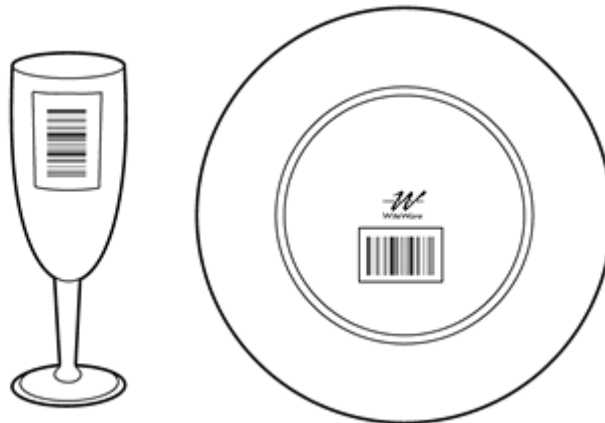
### Spot labels

Bar code symbols printed on spot labels that are applied to the trade item are acceptable alternatives that incorporate symbols into existing packaging graphics or for use on items without packages, such as some pots, pans, tableware, and glassware. The most suitable type of spot label is one that cannot be removed from the item without destroying the symbol. Labels that are applied directly to the product should use an adhesive that is strong enough to adhere to the label for an extended shelf life, but which also allows the label to be removed without the use of solvents or abrasives.

To determine proper bar code symbol placement on items bearing spot bar code symbol labels, follow the guidelines specific to the applicable package type/shape. (Refer to Section 6.4 for details on symbol placement for specific package types.)

Figure 6.3.3.7 - 4 Bar Code Symbol Placement with a Spot Label



**Figure 6.3.3.7 - 5 Tableware Items Using Bar Code Spot Labels**

### 6.3.3.8. Operational Considerations of Bar Code Placement

Speed, efficiency, and effectiveness in scanning operations are the ultimate goals of proper bar code symbol placement. To ensure that scanning performance will not be compromised, consider the following matters before deciding on final bar code symbol placement:

- Consistent symbol location

Compare your package/container to packaging for like products to ensure equivalent symbol placement. The ease with which bar code symbols are located by a cashier from product to product essentially relies on consistent symbol placement.

- Scan simulation (hand motion effectiveness)

Pass the bar code symbol across the scanner with your hand to test the initial bar code symbol placement. This test is intended to confirm that the bar code symbol placement does not necessitate unnatural hand motions while you are scanning the symbol.

### 6.3.3.9. Security Tag Placement

When a visible security tag is used, the preferred placement is within a 75 millimetres (3 inches) diameter of the bar code symbol placement. Consistent security tag placement makes it easier for the operator to predict security tag location and, thus, improves scanning efficiency.

## 6.4. Placement Guidelines for Specific Package Types

The following bar code symbol placement guidelines apply to specific package types. Section [6.5](#) contains diagrams illustrating symbol placement for clothing and fashion accessories. Figure 6.4 - 1, Package Type Reference, describes the main packaging categories and products. This figure can be used to determine correct bar code symbol placement by product or packaging. For example, according to the figure, a package of flower seeds in a 50 millimetres (2 inches) by 75 millimetres (3 inches) envelope is classified as a thin item or container. The example given of this type of package is powdered soft drink mix. According to the first column of the Package Type Reference, the correct bar code symbol placement for this package type can be determined by looking at Section [6.4.12](#).

**Figure 6.4 - 1 Package Type Reference**

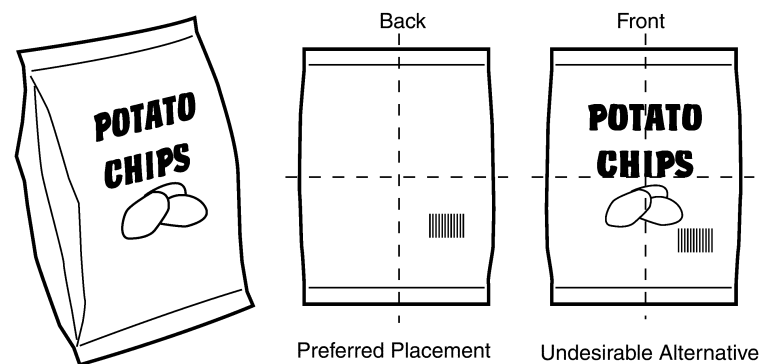
Section	Package Type	Package Characteristics	Product Examples
<a href="#">6.4.1</a>	Bags	Sealed cylindrical or rounded-corner wrapped units	Potato chips, flour, sugar, bird seed
<a href="#">6.4.2</a>	Blister packs	Flat card backing a formed clear plastic bubble placed over product	Toys, hardware parts
<a href="#">6.4.3</a>	Bottles and jars	Small or large-mouth vessels sealed with removable lids	Barbecue sauce, fruit jelly
<a href="#">6.4.4</a>	Boxes	Folded, sealed, heavy paper or corrugated cardboard cartons	Crackers, cereal, detergent
<a href="#">6.4.5</a>	Cans and cylinders	Cylindrical-shaped units sealed at each end	Soups, drinks, cheese, biscuits
<a href="#">6.4.6</a>	Carded items	Items mounted or sealed on flat cards	Hammers, parcels of candy, kitchen utensils
<a href="#">6.4.7</a>	Egg cartons	Irregular hexahedrons of plastic or moulded pulp with hinged lids	Eggs
<a href="#">6.4.8</a>	Jugs	Glass or plastic vessel with built-in handle(s) and removable lid(s)	Household cleaners, cooking oil
<a href="#">6.4.9</a>	Large, heavy, bulky items	Items having physical dimension of 450 mm (18 in.) or more in any two dimensions and/or weight in excess of 13 kg (28 lbs.)	Pet food, unassembled furniture, sledge hammers
<a href="#">6.4.10</a>	Multipacks	Multiple items mechanically bound to create one package	Soft drink cans
<a href="#">6.4.11</a>	Publishing items	Printed paper media that is bound, stapled, or folded	Books, magazines, newspapers, tabloids
<a href="#">6.4.12</a>	Thin items or containers	Items or containers with one dimension less than 25 mm (1 in.)	Boxes of pizza, CD jewel boxes, powdered soft drink mix packages, writing pads
<a href="#">6.4.13</a>	Trays	Flat, formed receptacles holding product covered with over-wrap	Prepared meats, pastries, snacks, pies, pie crusts
<a href="#">6.4.14</a>	Tubes	Firmly packed cylinders sealed at both ends, or sealed at one end with a cap or valve on the other end	Toothpaste, sausage, caulk
<a href="#">6.4.15</a>	Tubs	Deep vessels with removable lids	Margarine, butter, ice cream, whipped cream
<a href="#">6.4.16</a>	Unpackaged	Trade items that have no packaging, are often of an unusual shape, and are hard to label and scan	Frying pans, mixing bowls, cooking pots, giftware
<a href="#">6.4.17</a>	Sets	Trade items that can be sold individually or as part of a boxed set.	Table and giftware
<a href="#">6.4.18</a>	Sporting goods	Unpackaged items of specific size and shape.	Racquets, skis, skateboards

### 6.4.1. Bags

Although this category is referred to as “bags,” these packages/containers are often called sacks or pouches. This category includes paper or plastic containers that are:

- Fold-sealed on both ends (e.g., flour, sugar)
  - Fold-sealed on one end and pinched sealed at the other end (e.g., potato chips)
  - Pinch-sealed at both ends (e.g., cough drops)
  - Fold-sealed on one end and gathered at the other end (e.g., bread)
- ✓ **Note:** Some bags are sealed at both ends and carded for display, such as bags of sweets. These types of items are not considered bags but fall into the carded items category. (See Section [6.4.6](#) for details on carded items.)
- Package characteristics: Sealed cylindrical or rounded-corner wrapped units
  - Unique considerations: Bags have a tendency to have contents that shift and bulge. Consequently, bar code symbol placement must be on an area of the bag that is most likely to remain flat.
  - Bar code symbol placement: Identify the front of the package/container. (See Section [6.3.2](#) for instructions on how to identify the package front.)
    - Preferred placement: On the lower right quadrant of the back and away from the edge, respecting the proper Quiet Zone areas around the bar code symbol
    - Undesirable alternative: On the lower right quadrant of the front, and away from the edge, respecting the proper Quiet Zone areas around the bar code symbol
    - Edge rule: See Section [6.3.3.3](#).

Figure 6.4.1 - 1 Symbol Placement on Bags



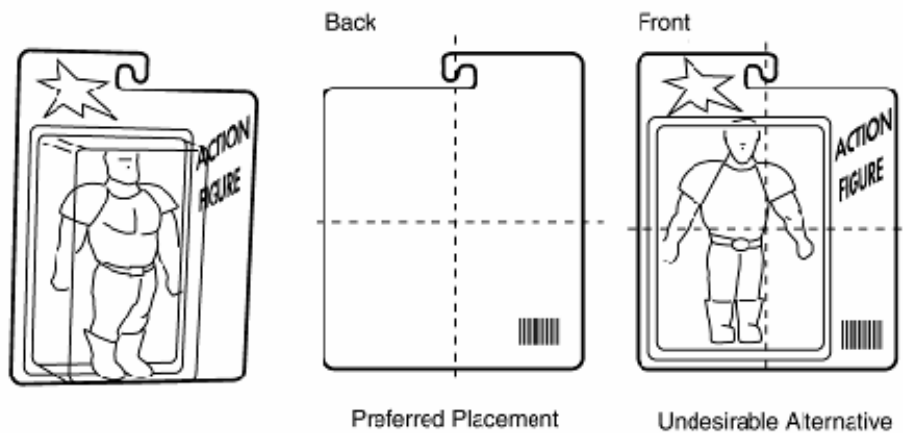
### 6.4.2. Blister Packs

Blister packs are pre-formed clear plastic bubbles, or blisters, containing a product and backed or topped with card stock.

- Package characteristics: Flat card, backing a formed clear plastic bubble placed over the product

- Unique considerations: To ensure quality scanning, the bar code symbol must be clear of the blister edges. Avoid placing the symbol under the blister pack or placing the symbol over any perforations on the back of the package.
- Bar code symbol placement: Identify the front of the package/container. (Refer to Section [6.3.2](#), Identifying the Back of the Trade Item, for instructions on how to identify the package front.)
  - Preferred placement: On the lower right quadrant of the back, near the edge, respecting the proper Quiet Zone areas around the bar code symbol
  - Undesirable alternative: On the lower right quadrant of the front, near the edge, respecting the proper Quiet Zone areas around the bar code symbol
  - Edge rule: See Section [6.3.3.3](#).

**Figure 6.4.2 - 1 Symbol Placement on Blister Packs**



### 6.4.3. Bottles and Jars

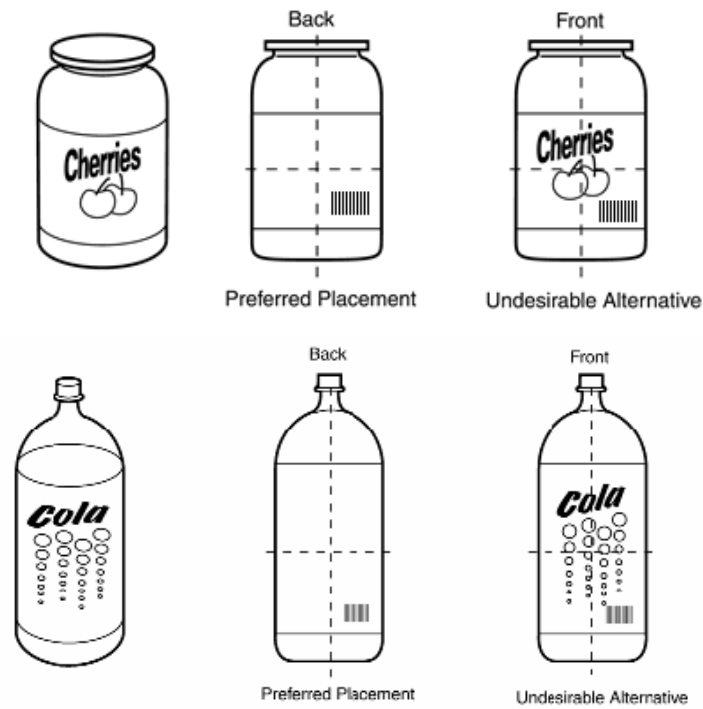
Bottles and jars normally carry spot labels applied to confined areas of the package, not covering the entire surface or wrapping around the entire perimeter.

- Package characteristics: Small or large-mouth containers sealed with removable lids
- Unique considerations: Application of the bar code symbol to the neck of a bottle is not allowed. Symbol placement on the neck of the bottle necessitates additional handling at the Point-of-Sale, and space limitations on this area of the bottle usually result in symbol truncation.

When a bar code symbol is printed onto a curved surface it is sometimes possible for the extremes of the symbol to disappear around the curve. See Section [6.2.3.2](#) for rules on the relationship between the diameter of the item and the X-dimension.

- Bar code symbol placement: Identify the front of the package/container. (Refer to Section [6.3.2](#), Identifying the Back of the Trade Item, for instructions on how to identify the package front.)
  - Preferred placement: On the lower right quadrant of the back, near the edge, respecting the proper Quiet Zone areas around the bar code symbol
  - Undesirable alternative: On the lower right quadrant of the front, near the edge, respecting the proper Quiet Zone areas around the bar code symbol
  - Edge rule: See Section [6.3.3.3](#).

Figure 6.4.3 - 1 Symbol Placement on Bottles and Jars

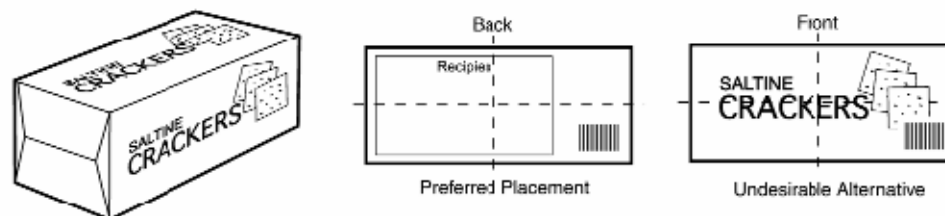


### 6.4.4. Boxes

This package type includes cuboid or cylindrical card or plastic cartons, as well as rectangular sleeves (used for products such as light bulbs). These packages might contain anything from crackers or cereal to detergent.

- Package characteristics: Folded, sealed, heavy paper or corrugated cardboard cartons
- Unique considerations: There are no unique considerations that apply to this package type.
- Bar code symbol placement: Identify the front of the package/container. (Refer to Section [6.3.2](#), Identifying the Back of the Trade Item, for instructions on how to identify the package front.)
  - Preferred placement: On the lower right quadrant of the back, near the edge, respecting the proper Quiet Zone areas around the bar code symbol
  - Undesirable alternative: On the lower right quadrant of the front, near the edge, respecting the proper Quiet Zone areas around the bar code symbol
  - Edge rule: See Section [6.3.3.3](#).

Figure 6.4.4 - 1 Symbol Placement on Boxes

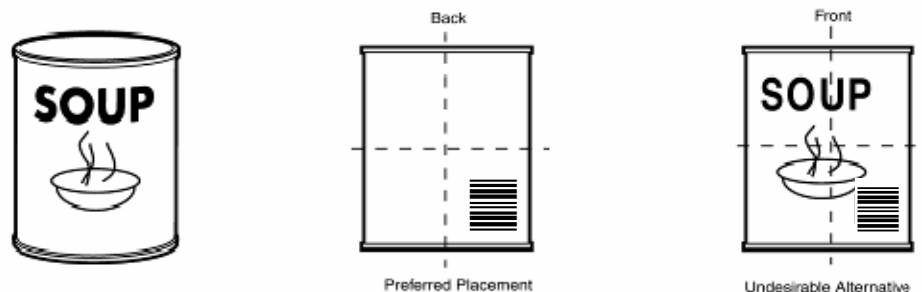


### 6.4.5. Cans and Cylinders

This category includes cylindrical shaped containers (usually made of plastic or metal) that are sealed at each end. Some containers have removable lids or openings. Common examples are canned fruit and vegetables, paints, and adhesives.

- Package characteristics: Cylindrical-shaped units sealed at each end
- Unique considerations: Obstacles, such as beading, seams, and/or ridges on the package/container should be avoided, because they will reduce scanning performance. When a bar code symbol is printed onto a curved surface it is sometimes possible for the extremes of the symbol to disappear around the curve. See Section [6.2.3.2](#) for rules on the relationship between the diameter of the item and the X-dimension.
- Bar code symbol placement: Identify the front of the package/container. (Refer to Section [6.3.2](#), Identifying the Back of the Trade Item, for instructions on how to identify the package front.)
  - Preferred placement: On the lower right quadrant of the back, near the edge, respecting the proper Quiet Zone areas around the bar code symbol
  - Undesirable alternative: On the lower right quadrant of the front, near the edge, respecting the proper Quiet Zone areas around the bar code symbol
  - Edge rule: See Section [6.3.3.3](#).

Figure 6.4.5 - 1 Symbol Placement on Cans and Cylinders

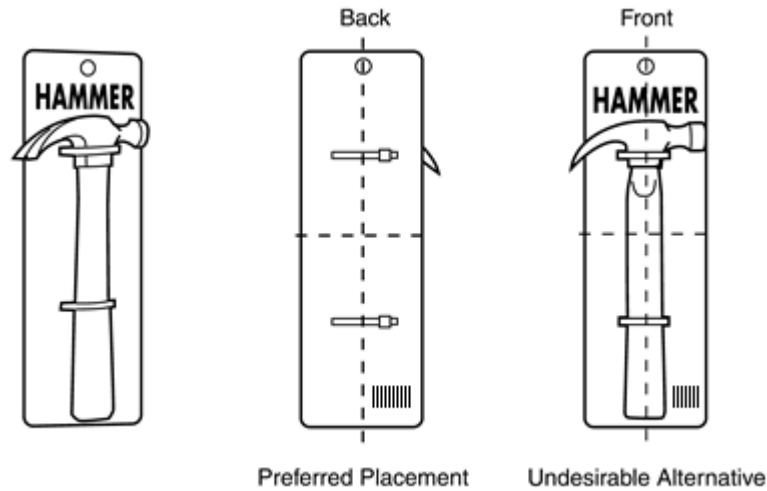


### 6.4.6. Carded Items

Small, loose, or non-packaged items that are difficult to label are placed on cards that are marked with a bar code symbol. Examples include hammers, toys, and kitchen utensils.

- Package characteristics: Items mounted or sealed on flat cards
- Unique considerations: When placing bar code symbols on carded items, it is important to take into consideration the proximity of the bar code symbol to the product. Be sure to allow adequate space for the symbol, avoiding any obstructions that might be caused by placing the symbol too close to the product. In addition, do not place the symbol over any perforations or other obstructions on the package.
- Bar code symbol placement: Identify the front of the package/container. (Refer to Section [6.3.2](#), Identifying the Back of the Trade Item, for instructions on how to identify the package front.)
  - Preferred placement: On the lower right quadrant of the back, near the edge, respecting the proper Quiet Zone areas around the bar code symbol
  - Undesirable alternative: On the lower right quadrant of the front, near the edge, respecting the proper Quiet Zone areas around the bar code symbol
  - Edge rule: See Section [6.3.3.3](#).

Figure 6.4.6 - 1 Symbol Placement on Carded Items

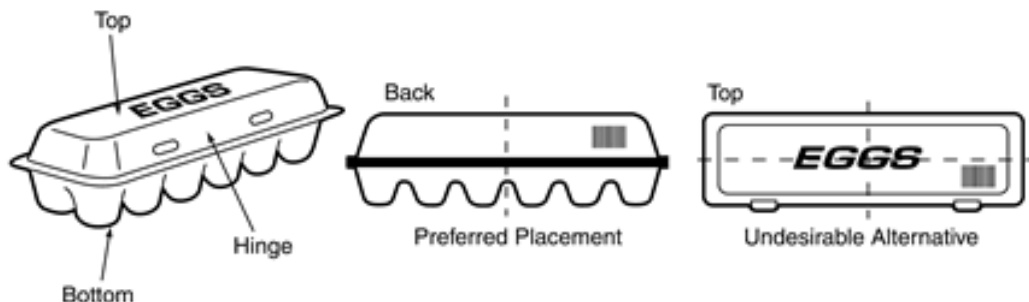


### 6.4.7. Egg Cartons

Moulded pulp, foam, or plastic egg cartons come in sizes according to the number of eggs contained.

- Package characteristics: Irregular shaped hexahedrons of plastic or moulded pulp with a hinged lid
- Unique considerations: The recommended symbol placement is on the side of the lid portion of the egg carton that opens and closes to cover the eggs. The uneven surface of the moulded bottom of an egg carton prevents bar code symbol placement in this area.
- Bar code symbol placement: To determine bar code symbol placement on an egg carton, first identify the top of the carton by locating the primary trading/advertising area, which is marked with the product name and the company's logo. The bottom of the egg carton is the moulded area directly opposite the top in which the eggs sit. The sides are divided horizontally by a hinged lid. The front of the carton is the long side containing the opening/closing mechanism. The back of the carton is directly opposite the front, on the long side with the hinge.
  - Preferred placement: Near the edge, on the right half of the back, above the hinge on the lid, respecting the proper Quiet Zone areas around the bar code symbol
  - Undesirable alternative: On the lower right quadrant of the top, on the lid adjacent to the opening/closing mechanism, near the edge, respecting the proper Quiet Zone areas around the bar code symbol
  - Edge rule: See Section [6.3.3.3](#).

Figure 6.4.7 - 1 Symbol Placement on Egg Cartons



### 6.4.8. Jugs

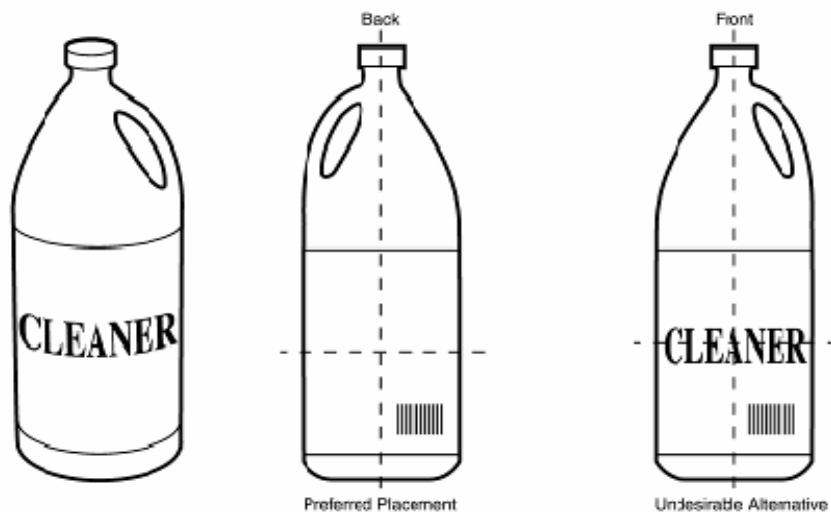
Jugs are glass or plastic containers with a built-in handle(s) that aids in pouring of contents. Jugs normally carry spot labels applied to defined areas of the package, not covering the entire surface of the trade item or wrapping around the entire perimeter of the item.

- Package characteristics: Glass or plastic vessels with built-in handles and removable lids
- Unique considerations: Application of the symbol to the neck of the jug is not allowed. Placement of the symbol on the neck of the jug necessitates additional handling at the Point-of-Sale, and space limitations on the neck usually result in symbol truncation.

When a bar code symbol is printed onto a curved surface it is sometimes possible for the extremes of the symbol to disappear around the curve. See Section [6.2.3.2](#) for the rules on the relationship between the diameter of the item and the X-dimension.

- Bar code symbol placement: Identify the front of the package/container. (Refer to Section [6.3.2](#), Identifying the Back of the Trade Item, for instructions on how to identify the package front.)
  - Preferred placement: On the lower right quadrant of the back, near the edge, respecting the proper Quiet Zone areas around the bar code symbol
  - Undesirable alternative: On the lower right quadrant of the front, near the edge, respecting the proper Quiet Zone areas around the bar code symbol
  - Edge rule: See Section [6.3.3.3](#).

Figure 6.4.8 – 1 Symbol Placement on Jugs



### 6.4.9. Large, Heavy, or Bulky Items

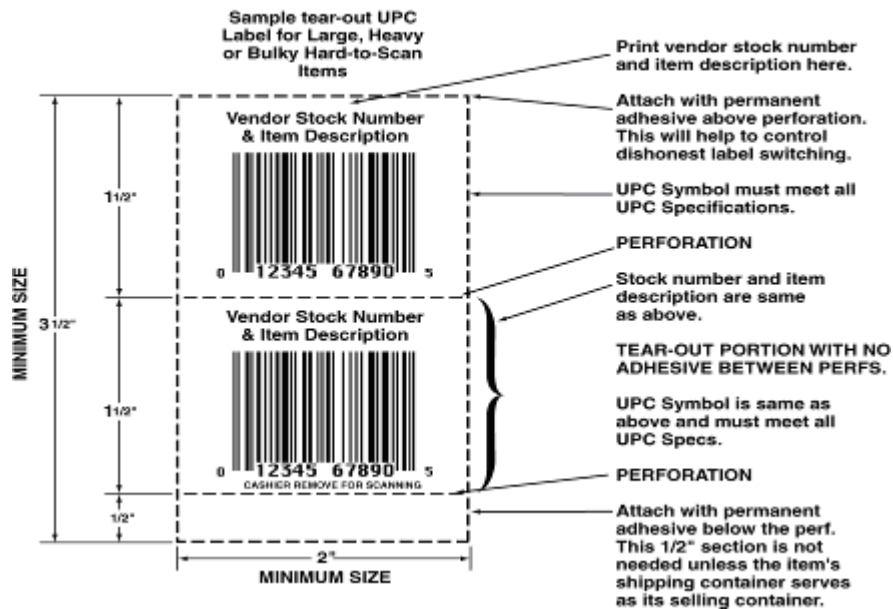
Large, heavy, or bulky items of any kind are difficult to handle and scan, and, therefore, different symbol placement guidelines apply.

- Package characteristics: Items considered large, heavy, or bulky have a physical dimension of 450 millimetres (18 inches) or more in any two dimensions (width/height, width/depth, or height/depth), and/or weigh in excess of 13 kilograms (28 pounds).
- Unique considerations:
  - Number of symbols: For large or heavy bags, two bar code symbols should be used, one on top of the front and one on the bottom of the back in opposite quadrants. For boxes, bottles, jars, cans, jugs, tubs, and unpackaged items, one bar code symbol is used.

- Special labels: A special double label with a tear-out bar code symbol may be applied to large, heavy, or bulky items that are too heavy or awkward to pick up and pass over a fixed scanner. This label has one section that is permanently adhered to the item’s box (or to a hang-tag or card if the item is not boxed). This section has a Human Readable Interpretation number and item description printed above a full-size bar code symbol. Beneath a perforation, a second section contains exactly the same human readable information and an identical full-size bar code symbol. The two sections are virtually identical except that the section below the perforation has no adhesive on its back.

**Figure 6.4.9 - 1**

**SAMPLE ILLUSTRATION OF THE DOUBLE LABEL WITH TEAR-OUT UPC**

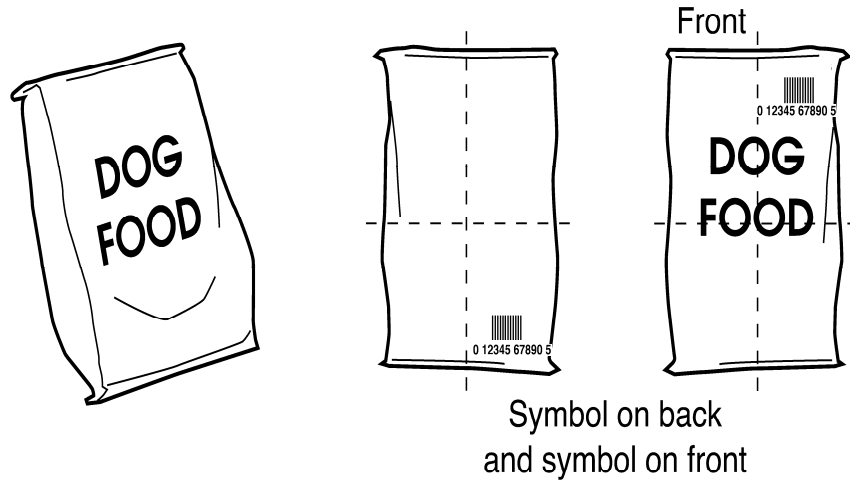


- When the item is brought to the Point-of-Sale, the lower half of the label below the perforation is removed. The cashier then either scans the label or, if the symbol cannot be scanned, the cashier key-enters the human readable information beneath the symbol. The top label remains attached to the item or its box.

In instances where the large, heavy, or bulky item is displayed and sold in its shipping container, a third section of label is recommended. Beneath the tear-out label, a second perforation and a 12 millimetres (0.50 inch) section with permanent adhesive should be added. This provides a more secure vehicle for the tear-out section and makes it less likely to tear off in transit.

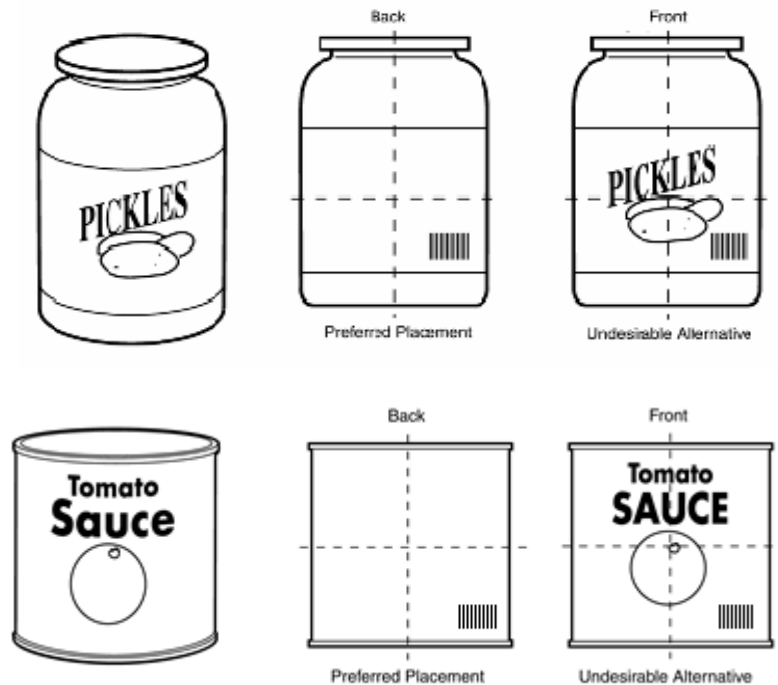
- Human Readable Interpretation: Human readable numbers or text on large, heavy, or bulky items should be a minimum of 16 millimetres (5/8 inch) high. This facilitates easier capture of the number by the cashier without having to pick up the product and move it across the scanner.
- Bar code symbol placement: Identify the front of the package/container. (See Section [6.3.2](#), Identifying the Back of the Trade Item, for instructions on how to identify the package front.)
- Preferred placement:
  - Bags: Two bar code symbols are required, one on the front of the bag, at the top of the upper right quadrant, near the edge, and the other on the back of the bag, centred in the lower right quadrant, near the edge (to accommodate settling of contents).

Figure 6.4.9 - 2 Symbol Placement on Large, Heavy, or Bulky Bags



- Bottles, jars, boxes, cans, jugs, tubs, and unpackaged items: These items are subject to the same symbol placement guidelines as corresponding smaller sized items. (Refer to the appropriate subsection in Section 6.4 for symbol placement guidelines for specific package types.)

Figure 6.4.9 - 3 Symbol Placement on Large, Heavy, or Bulky Jars, Cans, Jugs, or Tub



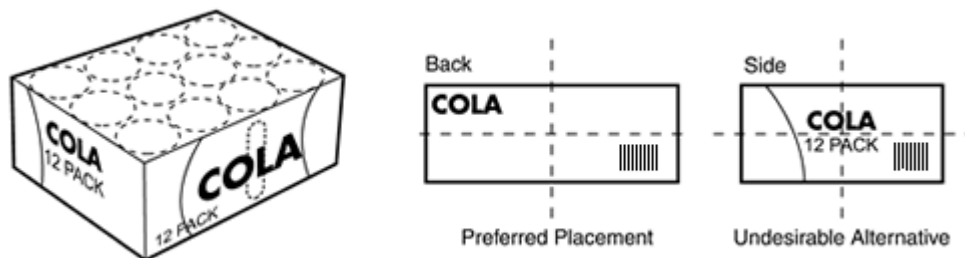
- Undesirable alternative: On the lower right quadrant of the front, near the edge, respecting the proper Quiet Zone areas around the bar code symbol
- Edge rule: See Section 6.3.3.3.

### 6.4.10. Multipacks

Multipacks are single items that are packaged together as one unit or trade item. Multipacks provide convenience to the consumer and/or may represent a price reduction compared to purchasing items individually. Typical multipacks contain bottles, cans, jars, and tubs.

- Package characteristics: Multiple single items bound together to create one package
- Unique considerations: As a general rule, a bar code symbol should be placed on every consumer package traded through the supply chain. Consequently, items sold in multipacks as well as those sold individually must carry a unique bar code symbol for each consumer package variation or aggregation. To avoid confusion at the Point-of-Sale, the multipack bar code symbol should be the only visible symbol when both the multipack and individual items are symbol-marked. The binder of the multipack acts as a screen to obscure the symbols on the individual items.
  - Special note for can multipacks: Avoid placing the symbol on the top or bottom of the container, since cans have a tendency to cause impressions in the corrugated cardboard and distort the symbol. These can impressions in the symbol may reduce scannability.
- Bar code symbol placement: Identify the front of the package/container. (Refer to Section [6.3.2](#), Identifying the Back of the Trade Item, for instructions on how to identify the package front.)
  - Preferred placement: On the lower right quadrant of the back, near the edge, respecting the proper Quiet Zone areas around the bar code symbol
  - Undesirable alternative: On the lower right quadrant of another side, near the edge, respecting the proper Quiet Zone areas around the bar code symbol
  - Edge rule: See Section [6.3.3.3](#).

Figure 6.4.10 - 1 Symbol Placement on Multipacks



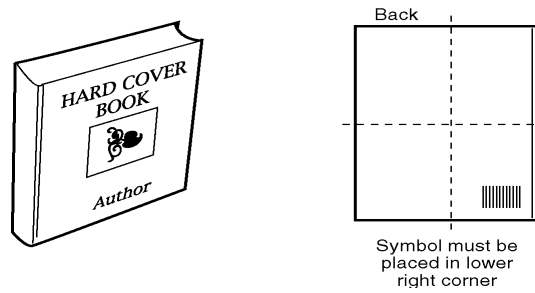
### 6.4.11. Publishing Items

Publishing items represent printed materials sold individually for consumer use including books, magazines, newspapers, and tabloids. Bar code symbol placement on published items varies depending on type. In addition, the main bar code symbols on books and paperbacks must appear on the outside cover of the book (to facilitate payment).

- Package characteristics: Printed paper media that is bound, stapled, or folded
- Unique considerations: In addition to the regular bar code symbol, some publishing items have Add-On Symbols that carry supplementary information such as an Issue Code. Bar code symbol placement on published items varies depending on the media type. If an Add-On Symbol is used, it must be located to the right of the regular bar code symbol and parallel to it.

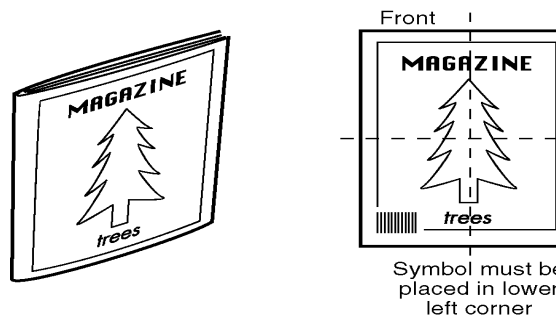
- Bar code symbol placement: Identify the front of the package/container. (Refer to Section 6.3.2, Identifying the Back of the Trade Item, for instructions on how to identify the package front.)
- Preferred placement:
  - Books: On the lower right quadrant of the back, near the spine, respecting the proper Quiet Zone areas around the bar code symbol

**Figure 6.4.11 - 1**



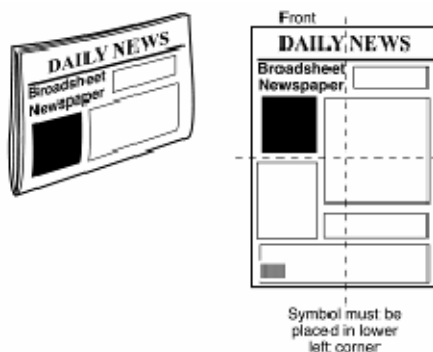
- Magazines: On the lower left quadrant of the front, near the edge, respecting the proper Quiet Zone areas around the bar code symbol

**Figure 6.4.11 - 2**



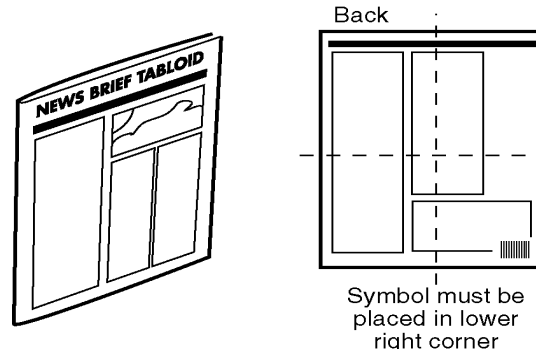
- Newspapers: When displayed for sale as shown on the left in Figure 6.4.11 - 3, place the symbol on the lower left quadrant of the front, near the edge, respecting the proper Quiet Zone areas around the bar code symbol. If an Add-On Symbol is used, it must be located to the right of the regular bar code symbol and parallel to it.

**Figure 6.4.11 - 3**



When displayed for sale as shown in Figure 6.4.11 - 4, place the symbol on the lower right quadrant of the back, near the edge, respecting the proper Quiet Zone areas around the bar code symbol. If an Add-On Symbol is used, it must be located to the right of the regular bar code symbol and parallel to it.

Figure 6.4.11 - 4



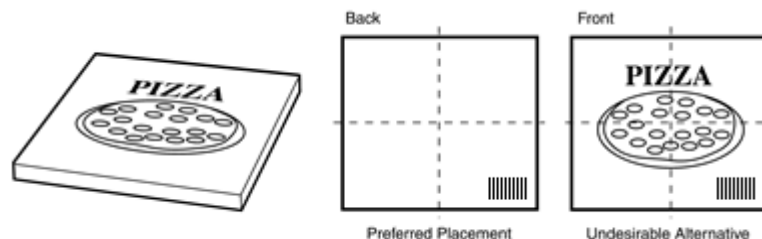
- Undesirable alternative: The undesirable alternative is not feasible for this package type.
- Edge rule: See Section [6.3.3.3](#).

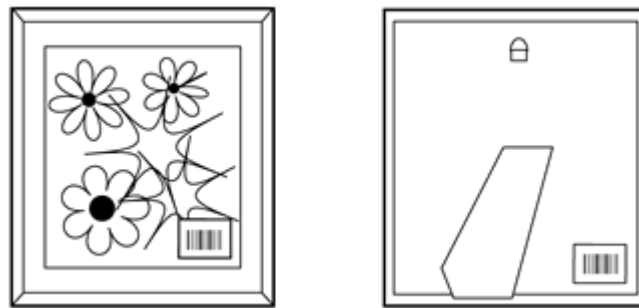
## 6.4.12. Thin Items or Containers

This package type is so named because items and containers in this category have one physical dimension less than 25 millimetres (1 inch). Items such as these, particularly those without a significant bottom surface, should be marked on the lower right quadrant of the back side. Boxes of pizza, compact disk boxes, packages of powdered drink mix, and writing pads are examples.

- Package characteristics: Items or containers with one dimension less than 25 millimetres (1 inch)
- Unique considerations: There are no unique considerations that apply to this package type.
- Bar code symbol placement: Identify the front of the package/container. (Refer to Section [6.3.2](#), Identifying the Back of the Trade Item, for instructions on how to identify the package front.)
  - Preferred placement: On the lower right quadrant of the back, near the edge, respecting the proper Quiet Zone areas around the bar code symbol
  - Undesirable alternative: On the lower right quadrant of the front, near the edge, respecting the proper Quiet Zone areas around the bar code symbol
  - Edge rule: See Section [6.3.3.3](#).

Figure 6.4.12 - 1 Symbol Placement on Thin Items or Containers

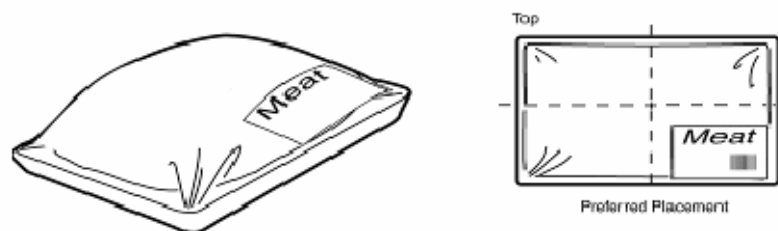


**Figure 6.4.12 - 2 Unpackaged Item Without Room for Bottom Marking**

### 6.4.13. Trays

This package type includes thin square, rectangular, or circular trays holding items that are covered with over-wrap of clear shrink-film or that are vacuum-sealed. Examples include meats, pastries, snacks, and pies or piecrusts.

- Package characteristics: Flat, formed receptacles holding product covered with over-wrap
- Unique considerations: When placing bar code symbols on trays, it is important to ensure that the bar code symbol is placed on a flat surface. In addition, do not place the symbol over any perforations or other obstructions on the package.
- Bar code symbol placement: Identify the front of the package/container. (Refer to Section [6.3.2](#), Identifying the Back of the Trade Item, for instructions on how to identify the package front.)
  - Preferred placement: On the lower right corner of the top, near the edge, respecting the proper Quiet Zone areas around the bar code symbol
  - Edge rule: See Section [6.3.3.3](#).

**Figure 6.4.13 - 1 Symbol Placement on Trays**

### 6.4.14. Tubes

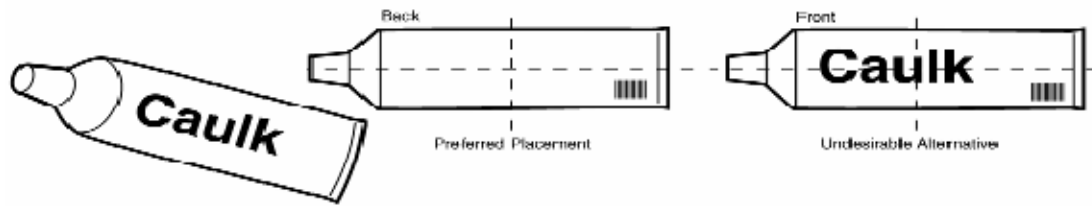
Tubes are cylindrical shaped items or containers that are either sealed at both ends, such as sausage or refrigerated dough, or that are sealed at one end and have a cap or valve on the other end, such as toothpaste or caulk.

- Package characteristics: Firmly packed cylinders sealed at both ends, or sealed at one end with a cap or valve on the other end
- Unique considerations: When a bar code symbol is printed onto a curved surface it is sometimes possible for the extremes of the symbol to disappear around the curve. See

Section [6.2.3.2](#) for the rules on the relationship between the diameter of the item and the X-dimension.

- Bar code symbol placement: Identify the front of the package/container. (Refer to Section [6.3.2](#), Identifying the Back of the Trade Item, for instructions on how to identify the package front.)
  - Preferred placement: On the lower right quadrant of the back, near the edge, respecting the proper Quiet Zone areas around the bar code symbol
  - Undesirable alternative: On the lower right quadrant of the front, near the edge, respecting the proper Quiet Zone areas around the bar code symbol
  - Edge rule: See Section [6.3.3.3](#).

Figure 6.4.14 - 1 Symbol Placement on Tubes

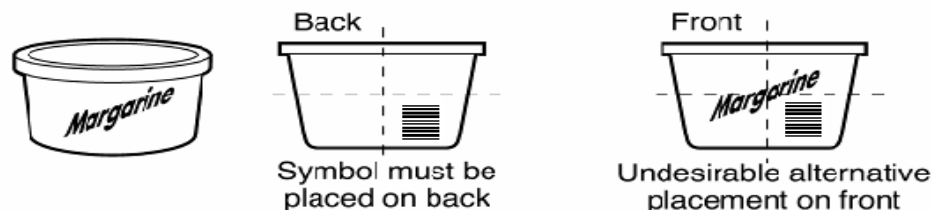


### 6.4.15. Tubs

Tubs are circular containers (usually made of paper, plastic, or metal) that have removable lids. In most cases, they have spot labels that do not cover the entire surface of the container. Examples include margarine, butter, ice cream, and whipped topping.

- Package characteristics: Deep vessels with removable lids
- Unique considerations: When a bar code symbol is printed onto a curved surface it is sometimes possible for the extremes of the symbol to disappear around the curve. See Section [6.2.3.2](#) for the rules on the relationship between the diameter of the item and the X-dimension.
- Bar code symbol placement: Identify the front of the package/container. (See Section [6.3.2](#), [Identifying the Back of the Trade Item](#), for instructions on how to identify the package front.)
  - Preferred placement: On the lower right quadrant of the back, near the edge, respecting the proper Quiet Zone areas around the bar code symbol
  - Undesirable alternative: On the lower right quadrant of the front, near the edge, respecting the proper Quiet Zone areas around the bar code symbol
  - Edge rule: See Section [6.3.3.3](#).

Figure 6.4.15 - 1 Symbol Placement on Tubs



### 6.4.16. Unpackaged Items

These are square, rectangular, circular, concave, or convex shaped items, including bowls, pots, pans, skillets, cups, vases, and other products (with or without contents), that lack an upright surface suitable for symbol placement.

- Package characteristics: These are items that are unpackaged and sold with spot labels, hangtags or carded sleeves.
- Unique considerations: When selecting symbol placement, consider the product's concave shape on the inside or irregular curvature on the outside while respecting the scanning distances defined in the edge rule below.
- The general marking guideline for a table and giftware items is to use a hangtag. This avoids any damage to the item that could be caused by the spot label adhesive. If this is not practical, the spot label should be applied to the bottom of the item and below the backstamp (where present).
- Bar code symbol placement: Bar code symbol placement on unpackaged items depends on the shape and type of the item. The following examples illustrate symbol placements appropriate to specific item types.
  - Preferred placement: The figures that follow indicate acceptable placement locations for other shaped items.
  - Undesirable alternative: The undesirable alternative is not applicable.
  - Edge rule: See Section [6.3.3.3](#).

Figure 6.4.16 - 1 Option 1

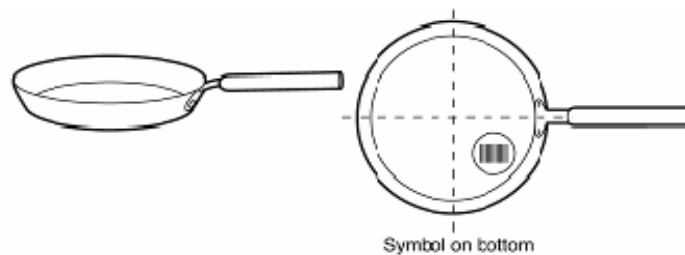


Figure 6.4.16 - 2 Option 2

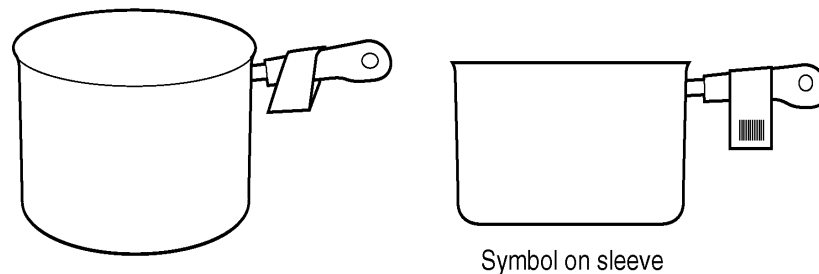


Figure 6.4.16 - 3 Option 3

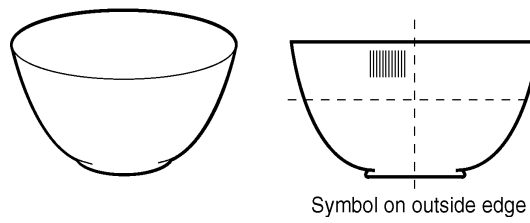


Figure 6.4.16 - 4 Option 4

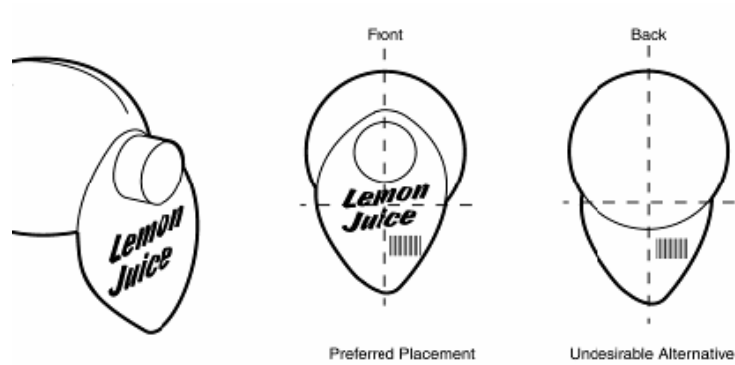
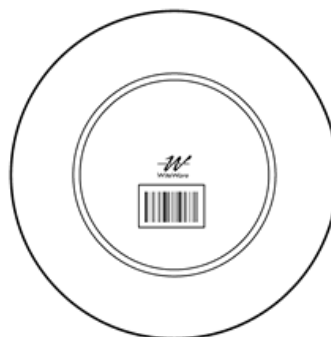


Figure 6.4.16 - 5 Option 5: Giftware Using Hangtag



Figure 6.4.16 - 6 Option 6: Tableware Using Spot Label Below Backstamp



### 6.4.17. Sets (Grouping of Individually Bar Coded Items)

For bar coding purposes, sets are defined as two or more items that are packaged and sold together as one unit, regardless of whether those items can be sold separately as well. If the items are packaged together for shipping purposes but are not intended to be sold as a single unit, they do not qualify as a set. Examples of sets include a pair of candlesticks, a set of four soup bowls, and a five-piece dinner place setting.

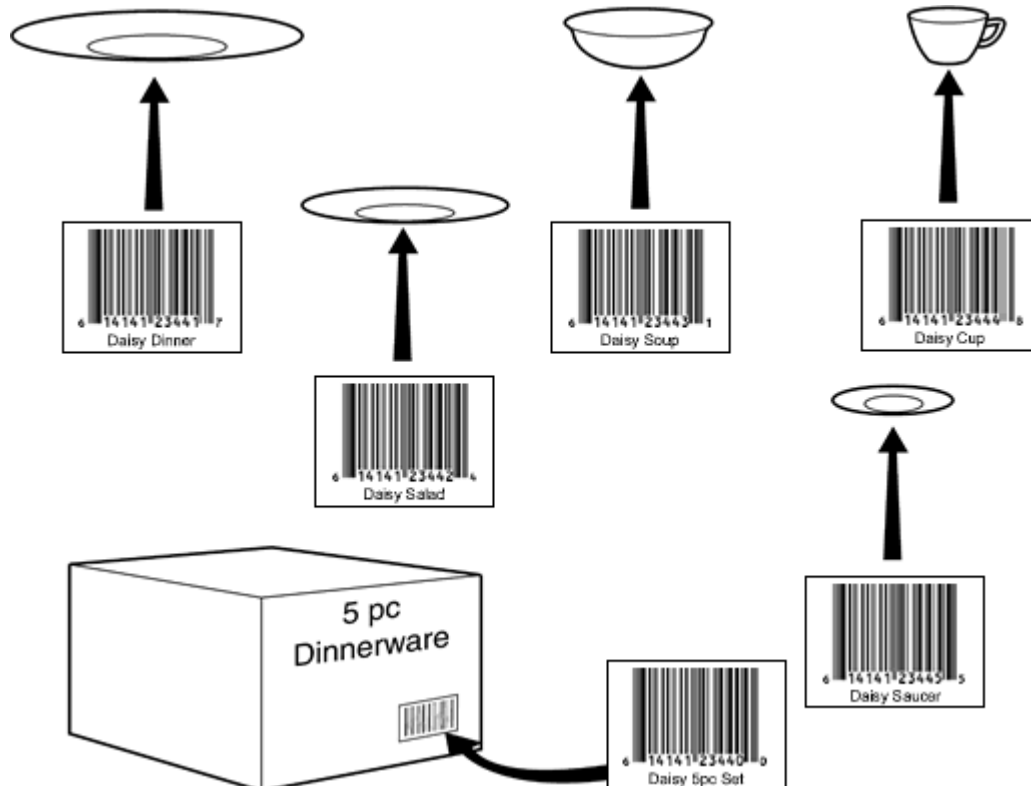
If a set is not intended to be sold as individual components, only the package for the set needs to include a bar code.

**Figure 6.4.17 - 1 Example of a Set Where Individual Components are Not Sold Separately**



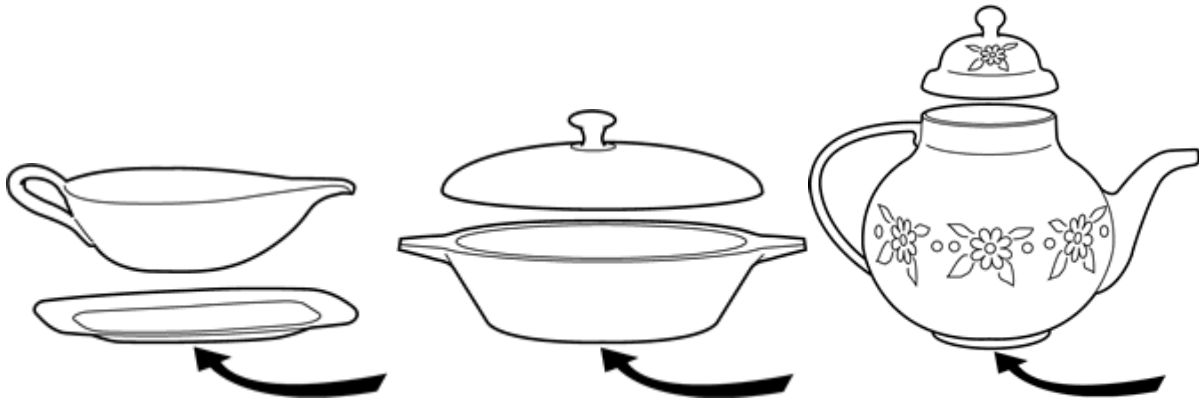
If the set is made up of components that can be ordered as separate trade items, then the components of the set must be marked. If the set can be sold as individual components or as the set, then both the package and the components need to be marked with unique symbols. The bar code symbols on the inner products must be totally obscured so that they cannot be read by the Point-of-Sale system when sold as a set. (See Section 6.3.3.7 for over-wrap special considerations.)

**Figure 6.4.17 - 2 Example of a Multi-Piece Set Sold as a Set or as Individual Components**



If an item is made up of multiple components that cannot be sold separately, such as a teapot with lid, the main piece only should be marked with one symbol. Such items are not considered sets.

**Figure 6.4.17 - 3 Items with Multiple Pieces that are Not Sold Separately (these are not considered sets)**



## 6.4.18. Sporting Goods

Sporting goods is a category composed of many irregular sized and shaped goods. An understanding of each product type, the logistics involved in the supply chain, and the sales floor presentation are key to improving the overall Point-of-Sale efficiency. Of particular importance is consistent bar code symbol placement for sporting goods as presented at the retail Point-of-Sale. This enables the Point-of-Sale operator to accurately predict the symbol location and thereby improve efficiency.

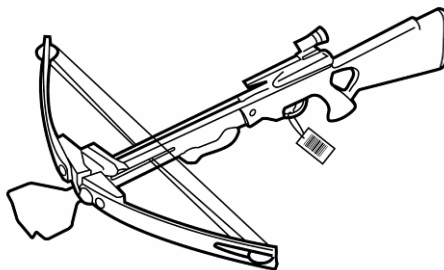
The following examples, while not exhaustive, provide the general principles that may be applied to similar product types. To view illustrative images, please visit:

[http://www.gs1.org/productsolutions/barcodes/technical/genspecs/sporting\\_goods.html](http://www.gs1.org/productsolutions/barcodes/technical/genspecs/sporting_goods.html).

### 6.4.18.1. Archery Bows, Arrows

- Preferred placement:
  - If packaged in boxes, see Section [6.4.4](#).
  - If packaged using a hangtag, see Section [6.5.2](#).
- Edge rule: See Section [6.3.3.3](#).

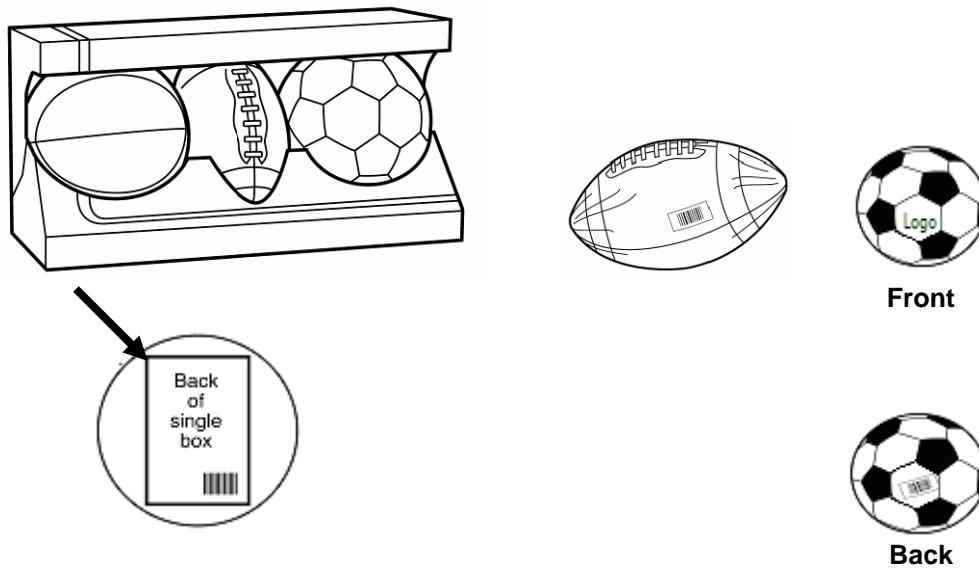
**Figure 6.4.18.1 - 1 Example Bar Code Location on an Archery Bow**



### 6.4.18.2. Balls, Team Sports

- Preferred placement:
  - If packaged individually, placement on the shrink wrap.
  - If packaged in boxes or boxed sets, see Section [6.4.4](#) and Section [6.4.17](#). If a master SKU is not utilized for a boxed set of balls or a pack set of ball and pump, each product type within the pack set should have a screened bar code symbol.
  - If not packaged, screen the bar code symbol on the opposite side of the logo on the ball.
- Edge rule: See Section [6.3.3.3](#)

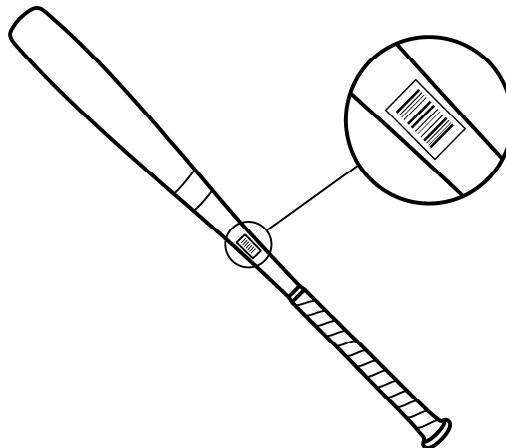
Figure 6.4.18.2 - 1 Example Bar Code Locations on a Box of Balls & Separate Balls



### 6.4.18.3. Bats, Team Sports

- Preferred placement: On the barrel handle of the bat, respecting the proper Quiet Zone areas around the bar code symbol.
- Edge rule: See Section [6.3.3.3](#)

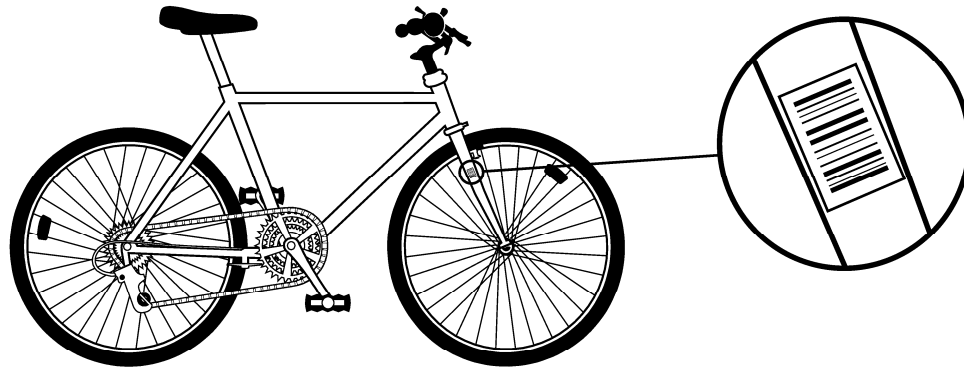
Figure 6.4.18.3 - 1 Example Bar Code Location on a Baseball Bat



#### 6.4.18.4. Bicycles

- Preferred placement: On the right hand fork of the bike, respecting the proper Quiet Zone areas around the bar code symbol.
- Undesirable alternative: On a hangtag around the right hand brake cable, respecting the proper Quiet Zone areas around the bar code symbol.
- Edge rule: See Section [6.3.3.3](#)

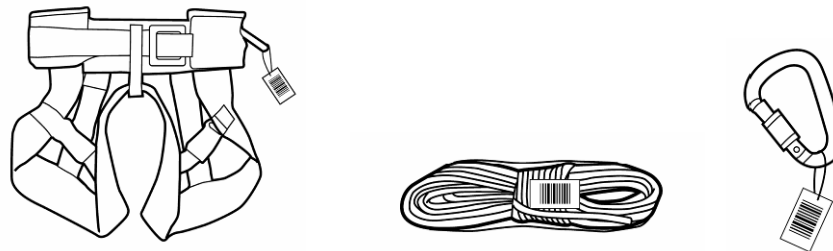
Figure 6.4.18.4 - 1 Example Bar Code Location on a Bicycle



#### 6.4.18.5. Climbing Gear

- Preferred placement:
  - If packaged in boxes, see Section [6.4.4](#)
  - If packaged using a hangtag, see Section [6.5.2](#)
  - If packaged as carded items, see Section [6.4.6](#)
- Edge rule: See Section [6.3.3.3](#)

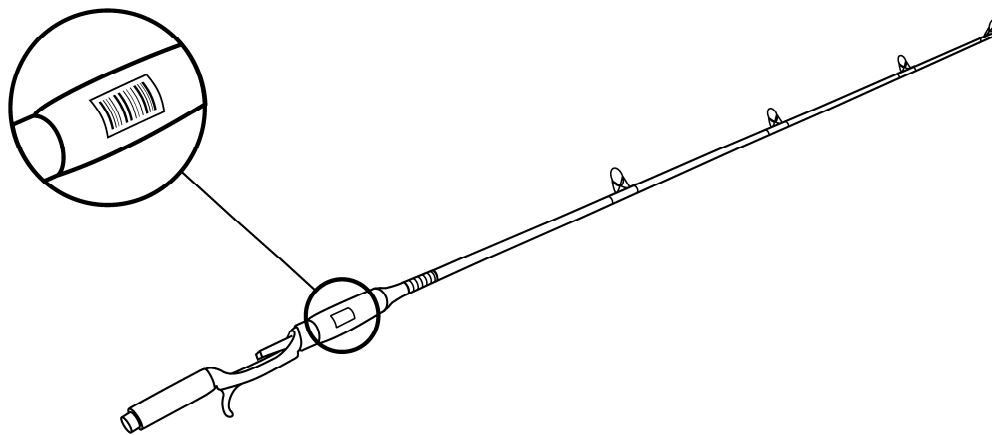
Figure 6.4.18.5 - 1 Example Bar Code Locations on Climbing Gear



### 6.4.18.6. Fishing Rods:

- **Preferred placement:** On the grip of the fishing rod near the sealed end, respecting the proper Quiet Zone areas around the bar code symbol. When a bar code symbol is printed onto a curved surface, it is sometimes possible for the extremes of the symbol to disappear around the curve. See Section [6.2.3.2](#) for the rules on the relationship between the diameter of the item and the X-dimension.
- **Undesirable alternative:** On a cardboard wrap or a hangtag on the shaft of the fishing rod, respecting the proper Quiet Zone areas around the bar code symbol.
- **Edge rule:** See Section [6.3.3.3](#)

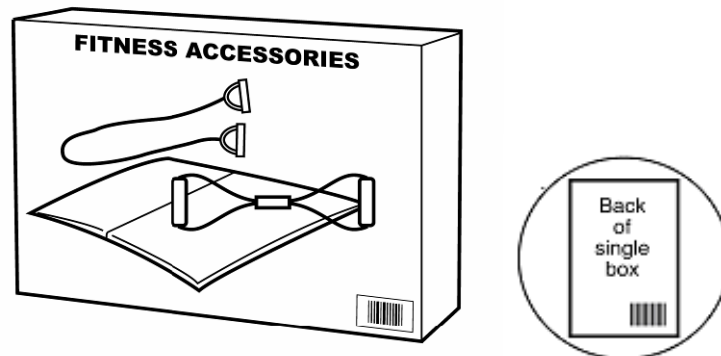
Figure 6.4.18.6 - 1 Example Bar Code Location on a Fishing Rod



### 6.4.18.7. Fitness Accessories

- Preferred placement:
  - If packaged in boxes, see Section [6.4.4](#)
  - If packaged using a hangtag, see Section [6.5.2](#)
  - If packaged as carded items, see Section [6.4.6](#)
- Edge rule: See Section [6.3.3.3](#)

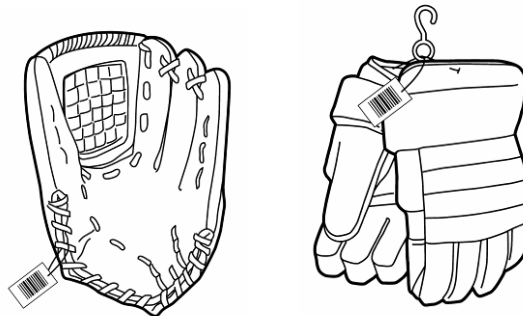
Figure 6.4.18.7 - 1 Example Bar Code Location on a Box of Fitness Accessories



### 6.4.18.8. Gloves, Mitts (Sports)

- Preferred placement:
  - If packaged in boxes, see Section [6.4.4](#)
  - If packaged using a hangtag, see Section [6.5.2](#)
  - If packaged in bags, see Section [6.4.1](#)
  - If not packaged, see Section [6.4.9](#)
- Edge rule: See Section [6.3.3.3](#)

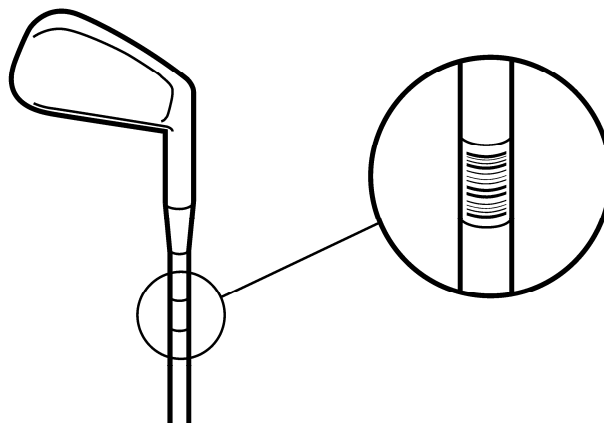
Figure 6.4.18.8 - 1 Example Bar Code Locations on Gloves



### 6.4.18.9. Golf Club:

- Preferred placement: On the shaft of the club located near the club head, respecting the proper Quiet Zone areas around the bar code symbol. When a bar code symbol is printed onto a curved surface, it is sometimes possible for the extremes of the symbol to disappear around the curve. See Section [6.2.3.2](#) for the rules on the relationship between the diameter of the item and the X-dimension. Symbols should not be located on the head of the golf club as symbols located on this flat area (normally preferable to locating bar codes on a curved surface) are easily damaged due to customer trials.
- Undesirable alternative: On the grip of the club near the sealed end, respecting the proper Quiet Zone areas around the bar code symbol.
- Edge rule: See Section [6.3.3.3](#)

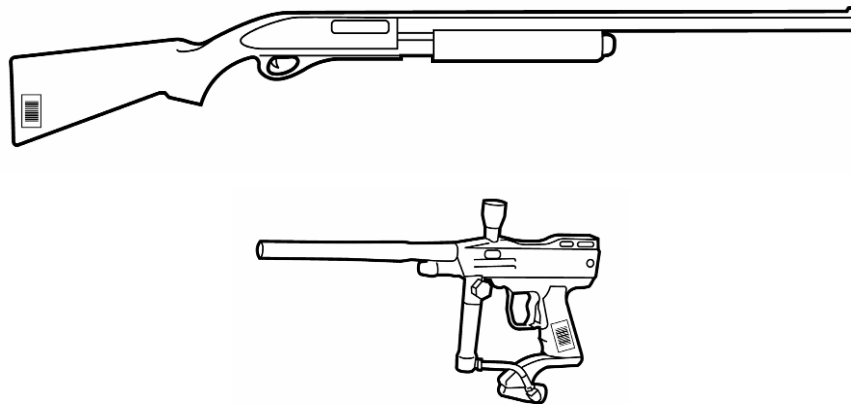
Figure 6.4.18.9 - 1 Example Bar Code Location on a Golf Club



#### 6.4.18.10. Guns

- Preferred placement:
  - If packaged using a hangtag, see Section [6.5.2](#)
  - If packaged as a blister pack, see Section [6.4.2](#)
  - If not packaged, placement near serial number
- Edge rule: See Section [6.3.3.3](#)

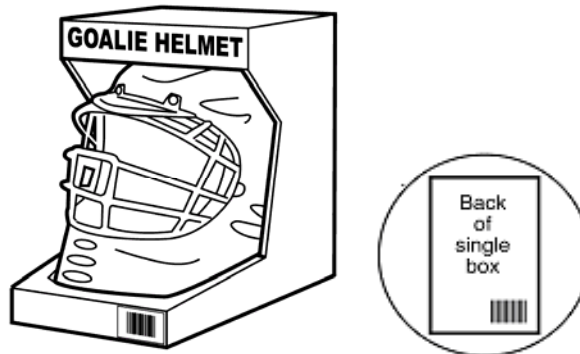
Figure 6.4.18.10 - 1 Example Bar Code Locations on a Rifle and Paint Ball Gun



#### 6.4.18.11. Helmets, Masks (Sports)

- Preferred placement:
  - If packaged in boxes, see Section [6.4.4](#)
  - If packaged using a hangtag, see Section [6.5.2](#)
  - If not packaged, see Section [6.4.9](#)
- Edge rule: See Section [6.3.3.3](#)

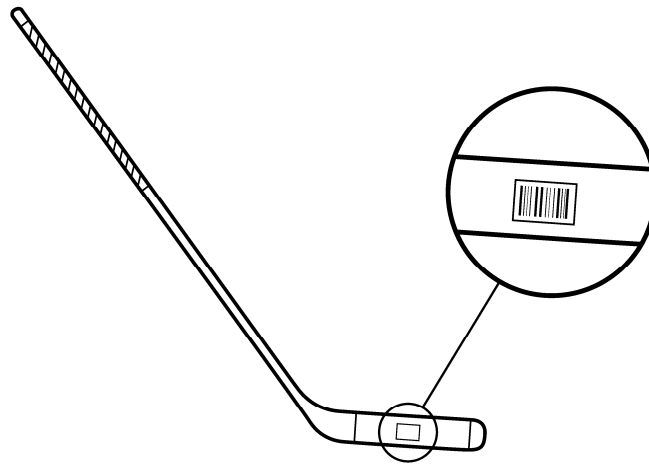
Figure 6.4.18.11 - 1 Example Bar Code Location on a Helmet



#### 6.4.18.12. Ice-Hockey and Field Hockey:

- Preferred placement: On the flat blade of the stick, respecting the proper Quiet Zone areas around the bar code symbol.
- Undesirable alternative: At the very top of the shaft of the stick, respecting the proper Quiet Zone areas around the bar code symbol. When a bar code symbol is printed onto a curved surface, it is sometimes possible for the extremes of the symbol to disappear around the curve. See Section [6.2.3.2](#) for the rules on the relationship between the diameter of the item and the X-dimension.
- Edge rule: See Section [6.3.3.3](#)

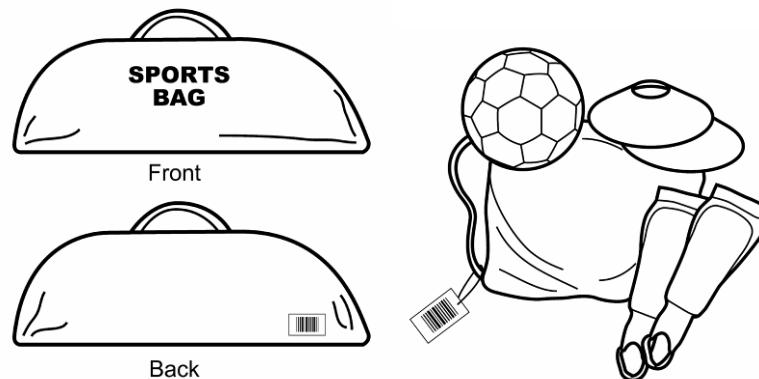
Figure 6.4.18.12 - 1 Example Bar Code Location on an Ice-Hockey Stick



#### 6.4.18.13. Multi-Sports-Product Pack Sets

- Preferred placement:
  - For placement on bags, see Section [6.4.1](#)
  - For placement on hangtags, see Section [6.5.2](#)
- Edge rule: See Section [6.3.3.3](#)

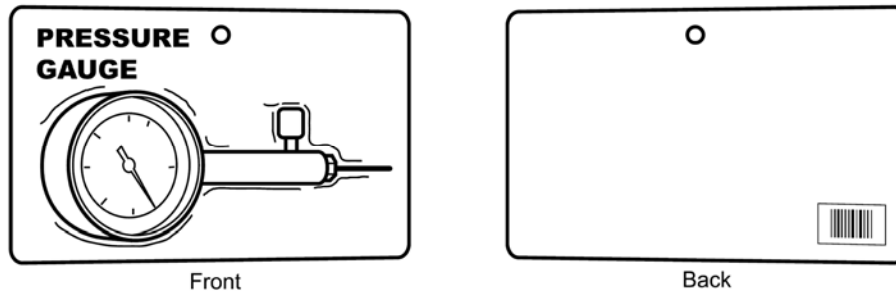
Figure 6.4.18.13 - 1 Example Bar Code Location on a Product Pack



#### 6.4.18.14. Pressure Gauges and Sports Pumps

- Preferred placement:
  - If packaged as carded items, see Section [6.4.6](#)
  - If packaged in bags, see Section [6.4.1](#)
  - If not packaged, placement on the wrap band securing the tip/needles, etc.
- Edge rule: See Section [6.3.3.3](#)

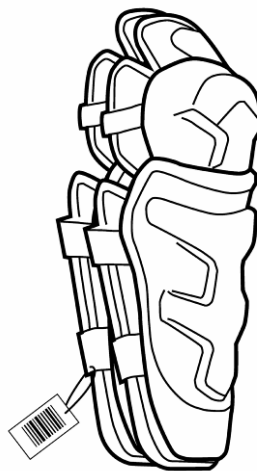
Figure 6.4.18.14 - 1 Example Bar Code Location on a Carded Item



#### 6.4.18.15. Protective Gear, Guards, Vests

- Preferred placement:
  - If packaged as a carded item, see Section [6.4.6](#)
  - If not packaged, see Section [6.4.9](#)
- Edge rule: See Section [6.3.3.3](#)

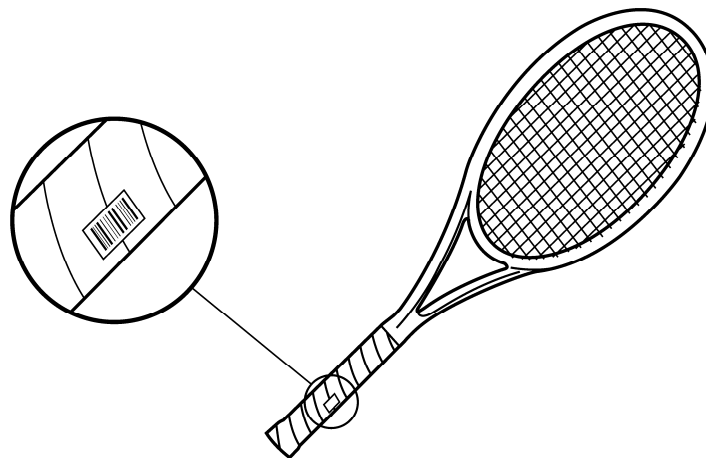
Figure 6.4.18.15 - 1 Example Bar Code Location on Guards



### 6.4.18.16. Racquets:

- Preferred placement: On the grip of the racquet near the sealed end, respecting the proper Quiet Zone areas around the bar code symbol. When a bar code symbol is printed onto a curved surface it is sometimes possible for the extremes of the symbol to disappear around the curve. See Section [6.2.3.2](#) for the rules on the relationship between the diameter of the item and the X-dimension.
- Undesirable alternative: On the cardboard wrap placed over the head of the racquet near the edge of the racquet head, respecting the proper Quiet Zone areas around the bar code symbol.
- Edge rule: See Section [6.3.3.3](#)

Figure 6.4.18.16 - 1 Example Bar Code Location on a Racquet

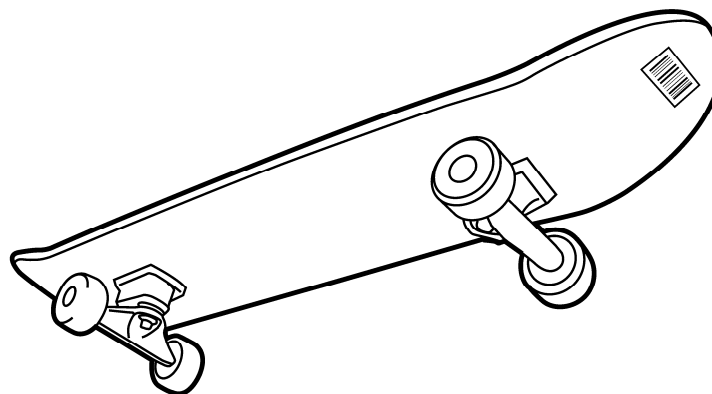


### 6.4.18.17. Skateboards:

Skateboards are often displayed in their packages. See Section [6.2.3](#), Orientation, to determine the back of the package. For unpackaged items:

- Preferred placement: On the bottom side of the skateboard on the top above the wheels, respecting the proper Quiet Zone areas around the bar code symbol.
- Edge rule: See Section [6.3.3.3](#)

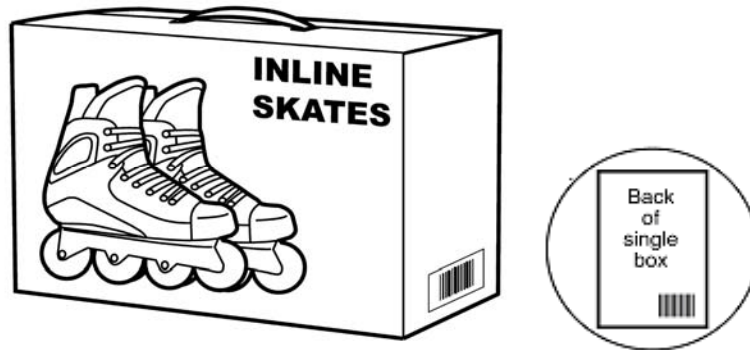
Figure 6.4.18.17 - 1 Example Bar Code Location on a Skateboard



#### 6.4.18.18. Skates

- Preferred placement:
  - If packaged in boxes, see Section [6.4.4](#)
  - If packaged using hangtags, see Section [6.5.2](#).
- Edge rule: See Section [6.3.3.3](#)

Figure 6.4.18.18 - 1 Example Bar Code Location on a Box of Skates

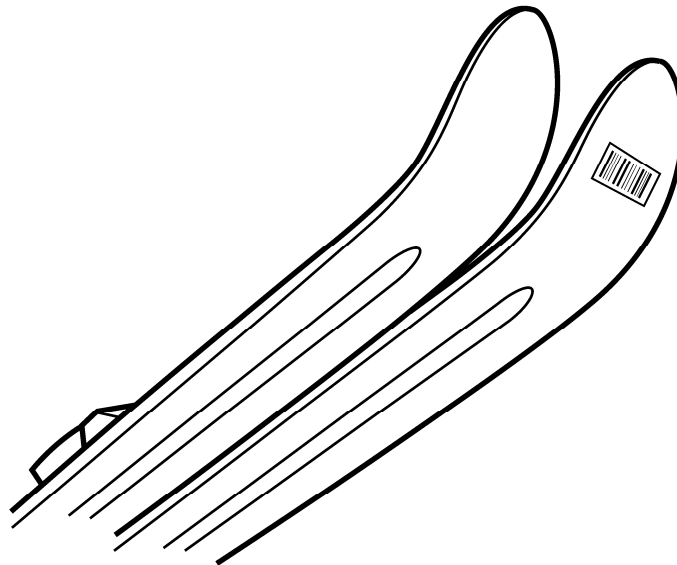


#### 6.4.18.19. Skis

Skis are displayed without their packaging. The front of the ski is the side where the ski boots are placed and the back of the ski is the opposite side.

- Preferred placement: One bar code symbol is placed on the back of the ski near the top of the ski, respecting the proper Quiet Zone areas around the bar code symbol. Only one bar code symbol is required per pair.
- Edge rule: See Section [6.3.3.3](#)

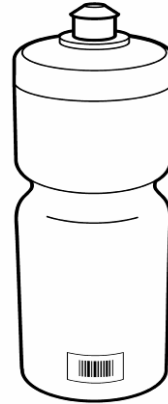
Figure 6.4.18.19 - 1 Example Bar Code Location on a Ski



#### 6.4.18.20. Water Bottles (Sports)

- Preferred placement:
  - If packaged in boxes, see Section [6.4.4](#)
  - If packaged using hangtags, see Section [6.5.2](#)
  - If not packaged, placement on the side of the bottle.
- Edge rule: See Section [6.3.3.3](#)

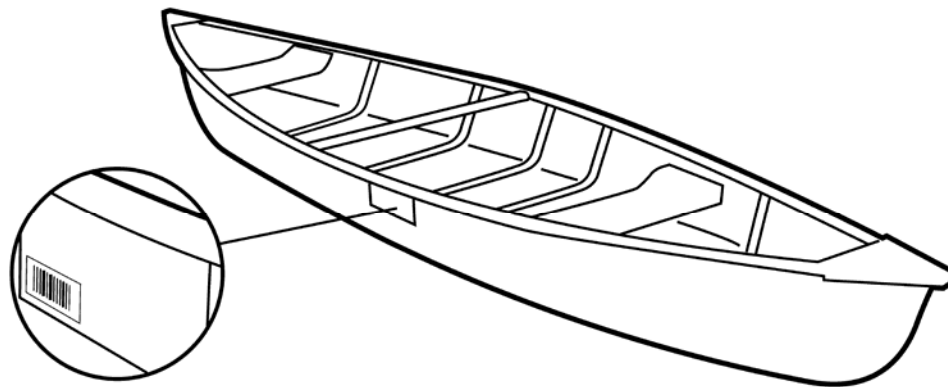
Figure 6.4.18.20 - 1 Example Bar Code Location on a Water Bottle



#### 6.4.18.21. Water Sports Crafts

- Preferred placement:
  - If packaged in boxes, see Section [6.4.4](#)
  - If packaged using hangtags, see Section [6.5.2](#)
  - If not packaged, see Section [6.4.9](#), Large, Heavy, or Bulky Items
- Edge rule: See Section [6.3.3.3](#)

Figure 6.4.18.21 - 1 Example Bar Code Location on a Canoe



### 6.4.19. Textured Surfaces

Some merchandise may not allow for application of bar code labels due to rough or textured surfaces. These surfaces can distort the label and thus the bar code. Alternative labelling options such as hang tags or loop tags may be necessary.

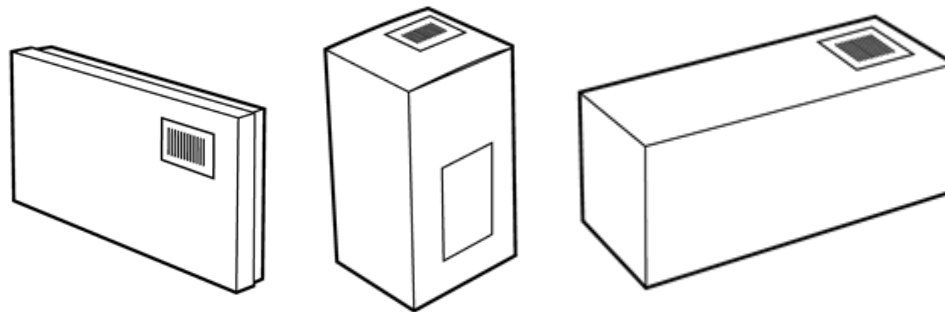
## 6.5. Symbol Placement for Clothing and Fashion Accessories

The following examples show recommended placement of symbols on clothing and fashion accessories. To view illustrative images, please visit:

[http://www.gs1.org/productssolutions/barcodes/technical/genspecs/clothing\\_and\\_fashion.html](http://www.gs1.org/productssolutions/barcodes/technical/genspecs/clothing_and_fashion.html).

Clothing is displayed in a variety of ways, such as loose (e.g., hanging garments), in boxes, or in bags. In many cases, a relatively small label must carry all the pertinent information relevant to the product. A retail label normally carries not only product-specific information important to the retailer (e.g., die lot, batch) and consumer related information (e.g., style, size, colour), but also the bar code symbol itself.

Figure 6.5 - 1 Example Bar Code Location on Boxes



The correct general layout for a retail label is indicated below. Because there are many clothing types on the retail market, detailed label formats are presented at:

[http://www.gs1.org/productssolutions/barcodes/technical/genspecs/clothing\\_and\\_fashion.html](http://www.gs1.org/productssolutions/barcodes/technical/genspecs/clothing_and_fashion.html).

- **Layout of label:** The label should be divided into three portions:
  - **Manufacturer/retailer information:** The upper portion of the format is the preferred location for Human Readable Interpretation product identification. This information is important to manufacturers and retailers, but usually not to the consumer.
  - **Bar code symbol:** The centre portion of the format is the best location for the bar code symbol. Symbols in this location are the least likely to present obstructions to scanners because a natural boundary exists between the manufacturer/retailer information (upper portion) and the consumer information (lower portion).
  - **Consumer information:** The lower portion of the format is the preferred location for information that is provided for the consumer, such as price, size, and fabric content.

**Label placement on clothing and fashion accessories:** To determine the placement of the printed label on clothing and fashion accessories, please visit:

[http://www.gs1.org/productssolutions/barcodes/technical/genspecs/clothing\\_and\\_fashion.html](http://www.gs1.org/productssolutions/barcodes/technical/genspecs/clothing_and_fashion.html).

### 6.5.1. Information Zones Concept

There are seven information zones that carry product information needed for the vendor, retailer, and consumer. Some information is optional based upon the type of label.

#### 6.5.1.1. General Label Information Zones

Zones	Information Type	Description	Status: Required/Optional
Zone 1	Merchandise identification	This is the primary human readable merchandise identifier, usually the style number, although it may be pattern, model, or garment type. The merchandise identifier should be located in the upper left-hand portion of Zone 1.	Always required  (see Note)
Zone 2	Vendor information	This includes optional vendor production information, such as vendor Stock Keeping Unit (SKU), cut number, dye lot, colour, and pattern. (Vendor information helps ensure that the correct bar code symbol is attached to the product.)	Optional
Zone 3	Data structure (GTIN-13, GTIN-12, GTIN-8)	Bar code symbol	Always required
Zone 4	Consumer information	This includes optional product information for the consumer, such as fibre content, fire retardancy, and country of origin.	Optional
Zone 5	Size/dimension	Size/dimension is a key requirement for the consumer. Size information can be emphasised in large bold print and should be located in the right-hand portion of Zone 5. Vendors may optionally include a style name as a selection aid for the consumer.	Usually required unless defined by the product (e.g., towels)
Zone 6	Retail price	Allow space to print the price with minimum dimension characters of 25 mm (1 in.) x 32 mm (1.25 in.). For plastic packaged, boxed, and banded products, the required space for price can be provided by several methods:  For bar code symbol marking on an adhesive label, the space for price can be included as part of the label.  For bar code symbol marking designed into the packaging, the space for price can be included on the package artwork.  Providing package space adjacent to Zone 5 that is reserved for retail item pricing creates an implied space for price. Implied space replaces the requirement for actual space on labels or package artwork.  If implied space for price is used, no information of importance should be printed in the area that might be covered by adhesive item price labels.	Usually required unless defined by the ticket format (e.g., sewn-in tickets)
Zone 7	Manufacturer's suggested retail price	This is for use only if merchandise is pre-priced or the suggested retail price is printed on the tag. If provided, the area must be perforated for optional removal.	Optional

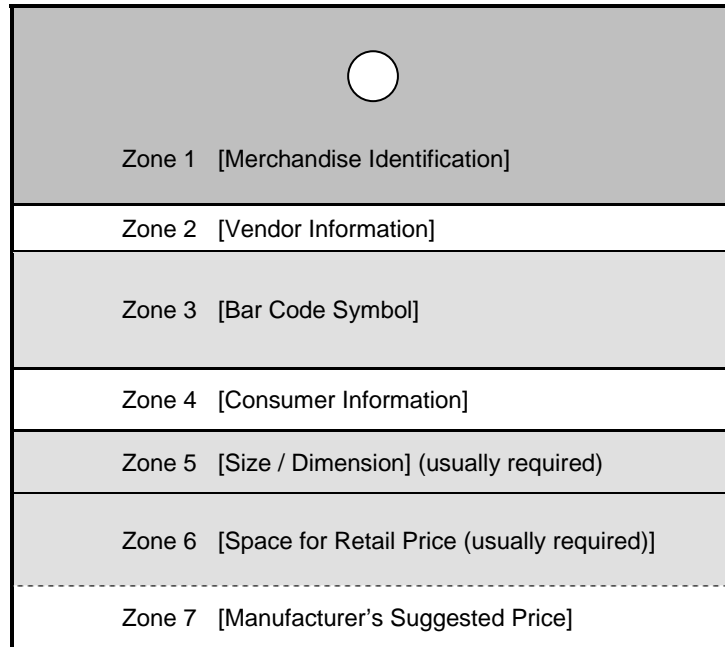


**Note:** Size and colour are optional in Zone 1 if vendor usage requires this information to define the product.

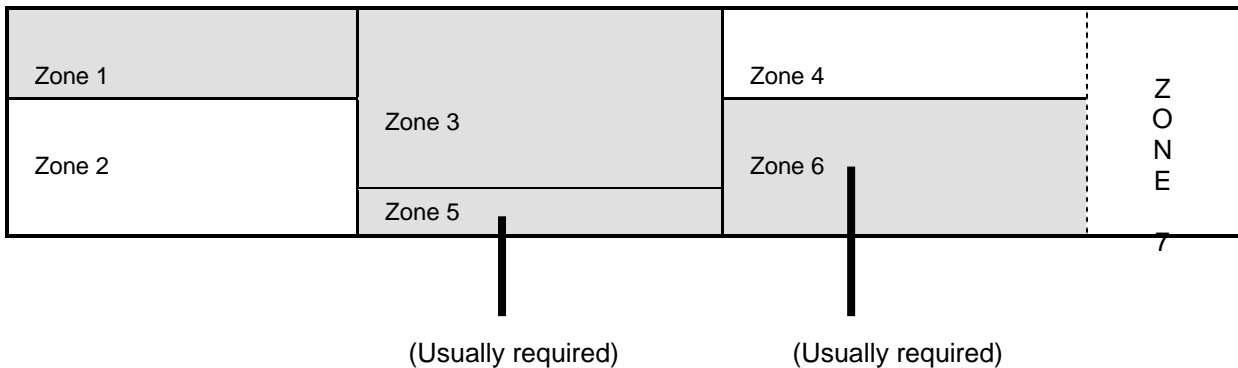
### 6.5.1.2. General Label Format

See the Figures 6.5.1.2 - 1 and 6.5.1.2 - 2 for examples of how the zones appear in a typical vertical and horizontal label format.

**Figure 6.5.1.2 - 1 Vertical Label Format**



**Figure 6.5.1.2 - 2 Horizontal Label Format**



KEY

Required	Optional
----------	----------

### 6.5.2. Hangtag (Hanging Label) Format

Although hangtags (hanging labels) are primarily associated with hanging ready-to-wear apparel, a wide variety of products are identified with hangtags. Flat-folded apparel, jewellery, belts, handbags, lamps, and furniture are all identified by some form of hangtag. Therefore, the voluntary hangtag format guidelines outlined in this section provide for flexibility in hangtag design while maintaining the overall concept of the information zones.

Hangtags serve a dual purpose. First, they provide brand identification to the consumer. Second, because the back of a hangtag is frequently used for product information and product identification codes, it should carry the bar code symbol that identifies the product.

The typical hangtag layout features the vendor's logo on the front and product identification codes and the bar code symbol on the back. Vendors may optionally include an additional logo on the back of the hangtags. However, a logo should not appear at the bottom because a retail price label may obscure it or it could be torn off if a manufacturer's suggested retail price is removed. Background printing of logos should be avoided, because this may obscure required information or important consumer information. Logos must never obscure the bar code symbol.

### 6.5.2.1. Hangtag Label Information Zones

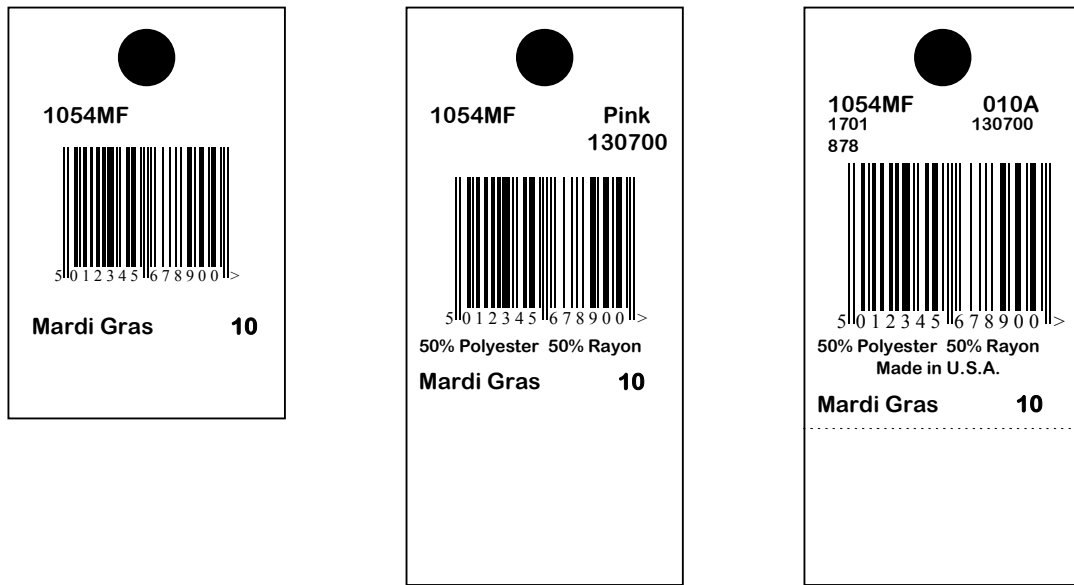
Zones	Information Type	Description	Status: Required/ Optional
Zone 1	Merchandise identification	This is the primary human readable merchandise identifier, usually the style number, although it may be pattern, model, or garment type. The merchandise identifier should be located in the upper left-hand portion of Zone 1.	Always required  (see Note)
Zone 2	Vendor information	This includes optional vendor production information, such as vendor Stock Keeping Unit (SKU), cut number, dye lot, colour, and pattern. (Vendor information helps ensure that the correct bar code symbol is attached to the product.)	Optional
Zone 3	Data structure (GTIN-13, GTIN-12, GTIN-8)	Bar code symbol	Always required
Zone 4	Consumer information	This includes optional product information for the consumer, such as fibre content, fire retardancy, and country of origin.	Optional
Zone 5	Size/dimension	Size/dimension is a key requirement for the consumer. Size information can be emphasised in large bold print and should be located in the right-hand portion of Zone 5. Vendors may optionally include a style name as a selection aid for the consumer.	Usually required unless defined by the product (e.g., towels)
Zone 6	Retail price	Allow space to print the price with minimum dimension characters of 25 mm (1 in.) x 32 mm (1.25 in.).	Usually required unless defined by the ticket format (e.g., sewn-in tickets)
Zone 7	Manufacturer's suggested retail price	This is for use only if merchandise is pre-priced or the suggested retail price is printed on the tag. If provided, the area must be perforated for optional removal.	Optional



**Note:** Size and colour are optional in Zone 1 if vendor usage requires this information to define the product.

### 6.5.2.2. Hanging Tag Label Examples

Figure 6.5.2.2 - 1



### 6.5.3. Sewn-On (Joker) Label Format

Used almost exclusively for apparel merchandise, joker labels are similar in format to hangtags, but differ in one important respect: They are sewn directly onto the product instead of hung from the product. Because it is sewn on, only one side of the label is available for the vendor's logo, the bar code symbol, and merchandise identification information.

Inclusion of a vendor logo on the label is optional. If it is included, it should not appear at the bottom, because it may be obscured by a retail price label, or it could be torn off by the removal of a manufacturer's suggested retail price. Background printing of logos should be avoided, because this may obscure required information or important consumer information. Logos must never obscure the bar code symbol.

#### 6.5.3.1. Sewn-On (Joker) Label Information Zones

Zones	Information Type	Description	Status: Required / Optional
Zone 1	Merchandise identification	This is the primary human readable merchandise identifier, usually the style number, although it may be pattern, model, or garment type. The merchandise identifier should be located in the upper left-hand portion of Zone 1.	Always required  (see Note)
Zone 2	Vendor information	This includes optional vendor production information, such as vendor Stock Keeping Unit (SKU), cut number, dye lot, colour, and pattern. (Vendor information helps ensure that the correct bar code symbol is attached to the product.)	Optional
Zone 3	Data structure (GTIN-13, GTIN-12, GTIN-8)	Bar code symbol	Always required

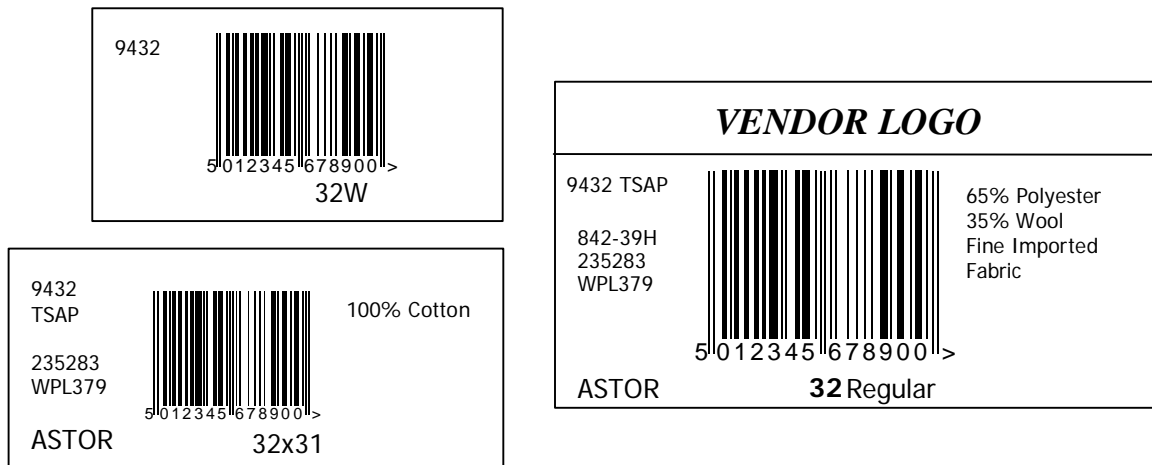
Zones	Information Type	Description	Status: Required / Optional
Zone 4	Consumer information	This includes optional product information for the consumer, such as fibre content, fire retardancy, and country of origin.	Optional
Zone 5	Size/dimension	Size/dimension is a key requirement for the consumer. Size information can be emphasised in large bold print and should be located in the right-hand portion of Zone 5. Vendors may optionally include a plain language style name on the size line as a selection aid for the consumer.	Usually required unless defined by the product (e.g., towels)
Zone 6	Retail price	Allow space to print the price with minimum dimension characters of 25 mm (1 in.) x 32 mm (1.25 in.).	Usually required unless defined by the ticket format (e.g., sewn-in tickets)
Zone 7	Manufacturer's suggested retail price	This is for use only if merchandise is pre-priced or the suggested retail price is printed on the tag. If provided, the area must be perforated for optional removal.	Optional

**Note:** Size and colour are optional in Zone 1 if vendor usage requires this information to define the product.

### 6.5.3.2. Sewn-On (Joker) Label Examples

Figure 6.5.3.2 - 1 Vertical Layout

Figure 6.5.3.2 - 2 Horizontal Layout



### 6.5.4. Sewn-In Label Formats

Sewn-in labels are often used for towel products. Sewn-in labels may be paper based, for removal by the consumer, or cloth based and more permanent.

Because a portion of the sewn-in label is normally covered by a hem, the label should be designed with sufficient blank space on the end that will be attached to the product. Care must be taken to ensure that the product identification information on the label is not obscured by the hem and that it does not interfere with the readability of the bar code symbol at the Point-of-Sale.

#### 6.5.4.1. Sewn-In Label Information Zones

Zones	Information Type	Description	Status: Required/Optional
Zone 1	Merchandise identification	This is the primary human readable merchandise identifier, usually the style number, although it may be pattern, model, or garment type. The merchandise identifier should be located in the upper left-hand portion of Zone 1.	Always required  (see Note)
Zone 2	Vendor information	This includes optional vendor production information, such as vendor Stock Keeping Unit (SKU), cut number, dye lot, colour, and pattern. (Vendor information helps ensure that the correct bar code symbol is attached to the product.)	Optional
Zone 3	Data structure (GTIN-13, GTIN-12, GTIN-8)	Bar code symbol	Always required
Zone 4	Consumer information	This includes optional product information for the consumer, such as fibre content, fire retardancy, and country of origin.	Optional
Zone 5	Size/dimension	Size or dimension is optional for sewn-in labels. Size or dimension may assist the consumer with product selection or may help the vendor ensure that the correct label and bar code symbol are attached to the product.	Usually required unless defined by the product (e.g., towels) and readily apparent to the consumer.

Zones	Information Type	Description	Status: Required/Optional
Zone 6	Retail price	Allow space to print the price with minimum dimension characters of 25 mm (1 in.) x 32 mm (1.25 in.).	Usually required unless defined by the ticket format (e.g., sewn-in tickets)
Zone 7	Manufacturer's suggested retail price	This is for use only if merchandise is pre-priced or the suggested retail price is printed on the tag. If provided, the area must be perforated for optional removal.	Optional

**Note:** Size and colour are optional in Zone 1 if vendor usage requires this information to define the product.

## 6.6. Plastic Packaged Products Label Location Guidelines

The plastic packaged category covers a wide assortment of merchandise, including sheets, pillowcases, table linens, pantyhose, underwear, stationery supplies, pillows, bedspreads, and numerous types of flat-folded apparel that are plastic packaged.

There are two methods of marking plastic packaged products with bar code symbols:

- Incorporate the bar code symbol and other merchandise identification information into the packaging's artwork.
- Print the bar code symbol and other merchandise identification information on an adhesive label that can be press-applied to the product.

Inclusion of a vendor logo on the label is optional. If it is included, the logo should not appear at the bottom, because it may be obscured by a retail price label, or it could be torn off by the removal of a manufacturer's suggested retail price. Background printing of logos should be avoided, because this may obscure required information or important consumer information. Logos must never obscure the bar code symbol.

### 6.6.1.1. Plastic Packaged Products Label Information Zones

Zones	Information Type	Description	Status: Required/Optional
Zone 1	Merchandise identification	This is the primary human readable merchandise identifier, usually the style number, although it may be pattern, model, or garment type. The merchandise identifier should be located in the upper left-hand portion of Zone 1.	Always required  (see Note 1)
Zone 2	Vendor information	This includes optional vendor production information, such as vendor Stock Keeping Unit (SKU), cut number, dye lot, colour, and pattern. (Vendor information helps to ensure that the appropriate bar code symbol is attached to the product.)	Optional
Zone 3	Data structure (GTIN-13, GTIN-12, GTIN-8)	Bar code symbol	Always required
Zone 4	Consumer information	This includes optional product information for the consumer, such as fibre content, fire retardancy, and country of origin.	Optional  (see Note 2)

Zones	Information Type	Description	Status: Required/Optional
Zone 5	Size/dimension	Size/dimension is a key requirement for the consumer. Size information can be emphasised in large bold print and should be located in the right-hand portion of Zone 5. Vendors may optionally include a style name as a selection aid for the consumer.	Usually required  (see Note 3)
Zone 6	Retail price	Allow space to print the price with 25 mm (1 in.) x 32 mm (1.25 in.) minimum dimension characters. For plastic packaged products, this required space for price can be provided by several methods:  For bar code symbol marking on an adhesive label, the space for price can be included as part of the label.  For bar code symbol marking designed into the packaging, the space for price can be included on the package artwork.  Providing package space adjacent to Zone 5 that is reserved for retail item pricing creates an implied space for price. Implied space replaces the requirement for actual space on labels or package artwork.  If implied space for price is used, no information of importance should be printed in the area that might be covered by adhesive item price labels.	Usually required
Zone 7	Manufacturer's suggested retail price	This is for use only if merchandise is pre-priced or the suggested retail price is printed on the tag. If provided, the area must be perforated for optional removal.	Optional

- Note 1:** Size and colour are optional in Zone 1 if vendor usage requires this information to define the product.
- Note 2:** Some jurisdictions require that certain products include a permanently affixed statement of information of this type in Zone 4 that may not be satisfied by inclusion on the package.
- Note 3:** Size may be omitted from Zone 5 if the size information is readily available on the product packaging.

### 6.6.1.2. Plastic Packaged Products Label Placement Guidelines

Consistent bar code symbol placement is required for successful scanning at the Point-of-Sale. The symbol placement guidelines for plastic packaged products have been designed with the flexibility to accommodate differences that may arise from industry to industry:

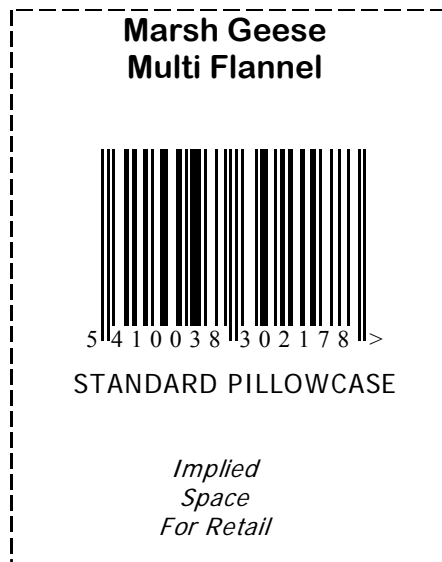
- On plastic packaged products, the front top right-hand corner is the preferred placement for the bar code symbol and other product identification information.
- The bar code symbol and other product identification information may be located on the front or back of plastic packaged products. However, all products within a particular merchandise category must have their bar code symbols placed on the same side of the package.

**Caution:** Placement of the bar code symbol on the back of a product may result in the presentation of the product on the display counter in a backside up orientation by some retailers so that the bar code symbol and retail price appear together in full view by the customer.

- The orientation of the bar code symbol and other product identification information should be consistent with any graphics or descriptive data on the plastic package.
  - Where possible, the symbol and other product identification information, whether built into the package artwork or an adhesive label, must not be closer than 8 millimetres (0.3 inch) or farther than 100 millimetres (4 inches) from the nearest edge of the package. Experience has shown that the previously recommended minimum distance of 5 millimetres (0.2 inch) is inadequate. Also, cashiers often grab packages on the edge with their thumbs. Avoid placing the bar code symbol too close to the edge. Such placement reduces Point-of-Sale efficiency and may cause distortion of the symbol. (See Section [6.3.3.3, Edge Rule.](#))
  - The bar code symbol and other product identification information on plastic packaged products should normally be located on the front top right-hand corner. However, for very large, bulky, or unusually shaped products, this may be impractical or inappropriate. See Section 6.4.9 for information on large, heavy, and bulky items.
- ✔ **Note:** Section 6.4 specifies the lower right quadrant of the back of the package or container as the recommended location for the bar code symbol. This recommendation applies to plastic packaged products that are sold in a grocery store environment.

### 6.6.1.3. Plastic Packaged Products Label Example

Figure 6.6.1.3 – 1



### 6.6.2. Boxed Products Label Formats

Some boxed products may be sold in or out of the box. Other boxed products are actually sets that may also be sold as individual items. Some boxes carry significant amounts of design graphics, while others are plain boxes containing the product.

Box size can range from very small, as in jewellery or cosmetics, to very large, as in home furnishings. For extremely large boxed products, consider using a two-part tear-off bar code symbol label to facilitate scanning at the Point-of-Sale while leaving one label on the box.

There are two methods of marking boxed products with bar code symbols:

- Incorporate the bar code symbol and other merchandise identification information the box's artwork.

- Print the bar code symbol and other merchandise identification information on an adhesive label that can be affixed to the box.

Inclusion of a vendor logo in the box marking format is optional. If the logo is included, it should not appear at the bottom, because it may be obscured by a retail price label, or it could be torn off if a manufacturer's suggested retail price is removed. Background printing of logos should be avoided, because this may obscure required information or important consumer information.

### 6.6.2.1. Boxed Products Label Information Zones

Zones	Information Type	Description	Status: Required/Optional
Zone 1	Merchandise identification	This is the primary human readable merchandise identifier, usually the style number, although it may be pattern, model, or garment type. The merchandise identifier should be located in the upper left-hand portion of Zone 1.	Always required  (see Note 1)
Zone 2	Vendor information	This includes optional vendor production information, such as vendor Stock Keeping Unit (SKU), cut number, dye lot, colour, and pattern. (Vendor information helps ensure that the correct bar code symbol is attached to the product.)	Optional
Zone 3	Data structure (GTIN-13, GTIN-12, GTIN-8)	Bar code symbol	Always required
Zone 4	Consumer information	This includes optional product information for the consumer, such as fibre content, fire retardancy, and country of origin.	Optional  (see Note 2)
Zone 5	Size/dimension	Size/dimension is a key requirement for the consumer. Size information can be emphasised in large bold print and should be located in the right-hand portion of Zone 5. Vendors may optionally include a style name as a selection aid for the consumer.	Usually required  (see Note 3)
Zone 6	Retail price	Allow space to print the price with minimum dimension characters of 25 mm (1 in.) x 32 mm (1.25 in.). For boxed products, this required space for price can be provided by several methods:  For bar code symbol marking on an adhesive label, the space for price can be included as part of the label.  For bar code symbol marking designed into the packaging, the space for price can be included on the package artwork.  Providing package space adjacent to Zone 5 that is reserved for retail item pricing creates an implied space for price. Implied space replaces the requirement for actual space on labels or package artwork.  If implied space for price is used, no information of importance should be printed in the area that might be covered by adhesive item price labels.	Usually required
Zone 7	Manufacturer's suggested retail price	For use only if merchandise is pre-priced or the suggested retail price is printed on the tag. If provided, the area must be perforated for optional removal.	Optional

- ✓ **Note 1:** Size and colour are optional in Zone 1 if vendor usage requires this information to define the product.
- ✓ **Note 2:** Some jurisdictions require that certain products include a permanently affixed statement of information of this type in Zone 4 that may not be satisfied by inclusion on the package.
- ✓ **Note 3:** Size may be omitted from Zone 5 if the size information is readily available on the product packaging.

### 6.6.2.2. Packaged Versus Freestanding Single Selling Units

Certain single selling units (trade items) may be sold as freestanding items, or they may be sold in a package. This creates a dilemma for the supplier: to mark the item or mark the package? For GTIN Allocation Rules pertaining to this scenario, see Section 2.1.

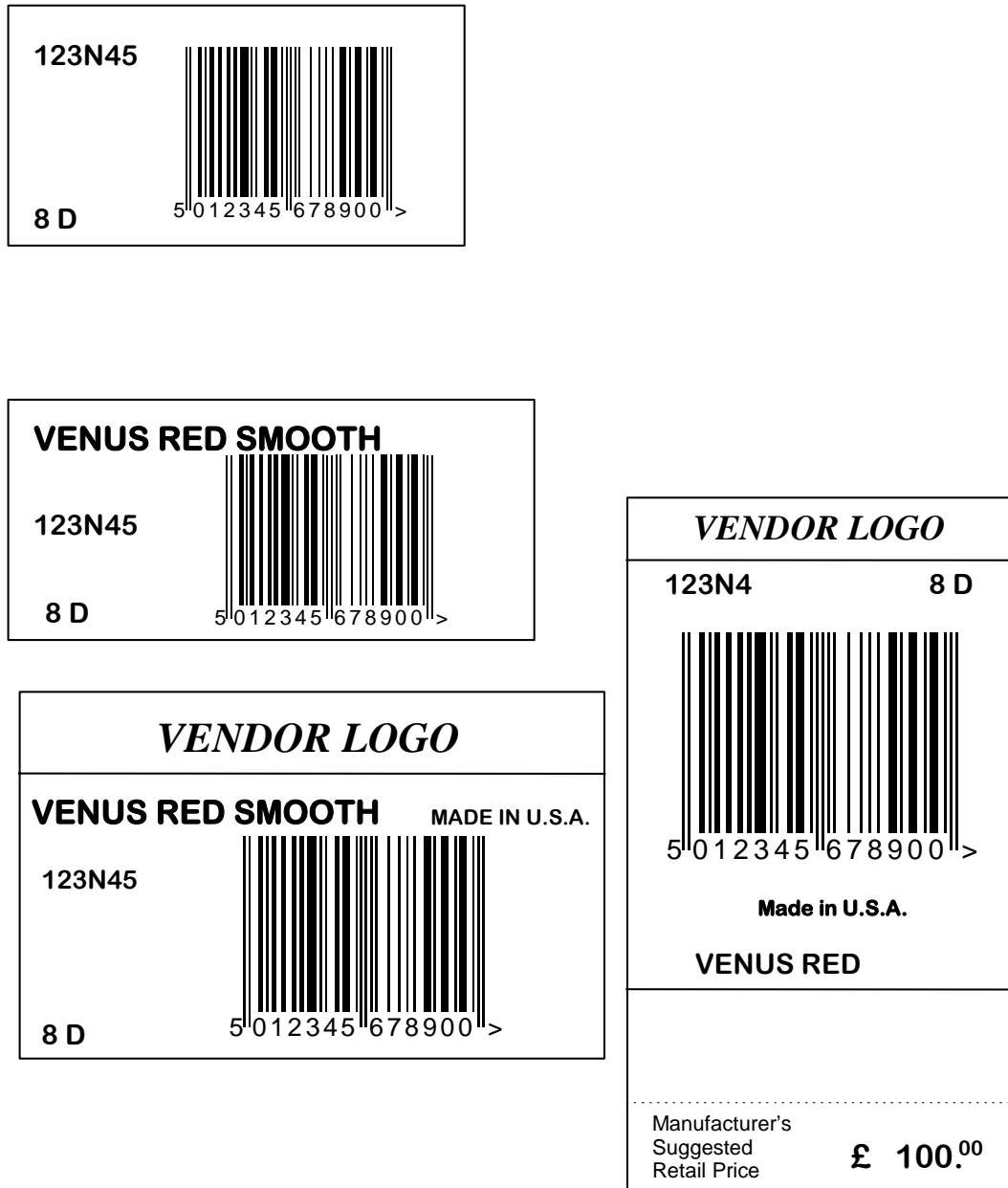
### 6.6.2.3. Boxed Products Label Placement Guidelines

Consistent bar code symbol placement within an industry or product category is required if merchandise carrying a bar code symbol is to successfully scan at the Point-of-Sale. Since the category of boxed products includes a diverse merchandise group, location guidelines have been designed with considerable flexibility to accommodate differences that may arise from industry to industry:

- The exposed surface of the box is the preferred location for bar code symbols and other product identification information on boxed products sold primarily in the department or specialty store environment.
  - The orientation of the bar code symbol and other product identification information should be consistent with any graphics or descriptive data on the box.
  - Where possible, the symbol and other product identification information, whether built into the package artwork or an adhesive label, must not be closer than 8 millimetres (0.3 inch) or farther than 100 millimetres (4 inches) from the nearest edge of the package. Experience has shown that the previously recommended minimum distance of 5 millimetres (0.2 inch) is inadequate. Also, cashiers often grab packages on the edge with their thumbs. Avoid placing the bar code symbol too close to the edge. Such placement reduces Point-of-Sale efficiency and may cause distortion of the symbol. (See Section [6.3.3.3, Edge Rule.](#))
  - The bar code symbol and other product identification information on plastic packaged products should normally be located on the front top right-hand corner. However, for very large, bulky, or unusually shaped products, this may be impractical or inappropriate. See Section [6.4.9](#) for information on large, heavy, and bulky items.
- ✓ **Note:** Section [6.4](#) specifies the lower right quadrant of the back of the package or container as the recommended location of the bar code symbol. This recommendation applies to plastic packaged products that are sold in a grocery store environment.

### 6.6.2.4. Boxed Products Label Examples

Figure 6.6.2.4 - 1



### 6.6.3. Banded Products Label Formats

Banded packaging involves a specialised group of products. This type of packaging is most commonly associated with hosiery (socks) or yarn products.

There are the two methods of marking banded products with bar code symbols:

- Incorporate the bar code symbol and other merchandise identification information into the band's artwork.
- Print the bar code symbol and other merchandise identification information on an adhesive label that can be applied to the band.

The typical banded product label has the vendor's logo on the front and the product identification codes, consumer information, and bar code symbol on the back. The vendor's logo can also be printed on the back of the band as part of the band marking format. However, care should be taken to ensure that there is no obstruction of the bar code symbol or other important product identification information. Background printing of logos should also be avoided.

### 6.6.3.1. Banded Products Label Information Zones

Zones	Information Type	Description	Status: Required/Optional
Zone 1	Merchandise identification	This is the primary human readable merchandise identifier, usually the style number, although it may be pattern, model, or garment type. The merchandise identifier should be located in the upper left-hand portion of Zone 1.	Always required  (see Note 1)
Zone 2	Vendor information	This includes optional vendor production information, such as vendor Stock Keeping Unit (SKU), cut number, dye lot, colour, and pattern. (Vendor information helps ensure that the correct bar code symbol is attached to the product.)	Optional
Zone 3	Data structure (GTIN-13, GTIN-12, GTIN-8)	Bar code symbol	Always required
Zone 4	Consumer information	This includes optional product information for the consumer, such as fibre content, fire retardancy, and country of origin.	Optional  (see Note 2)
Zone 5	Size/dimension	Size/dimension is a key requirement for the consumer. Size information can be emphasised in large bold print and should be located in the right-hand portion of Zone 5. Vendors may optionally include a style name as an aid to the consumer in selection.	Usually required  (see Note 3)
Zone 6	Retail price	Allow space to print the price with minimum dimension characters of 25 mm (1 in.) x 32 mm (1.25 in.). For banded products, this required space for price can be provided by several methods:  For bar code symbol marking on an adhesive label, the space for price can be included as part of the label.  For bar code symbol marking designed into the packaging, the space for price can be included on the package artwork.  Providing package space adjacent to Zone 5 that is reserved for retail item pricing creates an implied space for price. Implied space replaces the requirement for actual space on labels or package artwork.  If implied space for price is used, no information of importance should be printed in the area that might be covered by adhesive item price labels.	Usually required
Zone 7	Manufacturer's suggested retail price	This is for use only if merchandise is pre-priced or the suggested retail price is printed on the tag. If provided, the area must be perforated for optional removal.	Optional



**Note 1:** Size and colour are optional in Zone 1 if vendor usage requires this information to define the product.

- Note 2:** Some jurisdictions require that certain products include a permanently affixed statement of information of this type in Zone 4 that may not be satisfied by inclusion on the package.
  
- Note 3:** Size may be omitted from Zone 5 if the size information is readily available on the product packaging.

## 6.7. GS1 Logistics Label Design

These specifications constitute the basis for all GS1 logistics labels. Other sections, most notably Section 3, GS1 Application Identifier Definitions, and Section 5.4, GS1-128 Symbology Specifications, should be read in conjunction with the following sub-sections.

### 6.7.1. Scope

These specifications detail the structure and layout of GS1 logistics labels. Emphasis is given to the basic requirements for practical application in an open trade environment. Primary topics include:

- The unambiguous identification of logistic units
- The efficient presentation of text and machine readable data
- The information requirements of the key partners in the supply chain: suppliers, customers, and carriers
- Technical parameters to ensure systematic and stable interpretation of labels

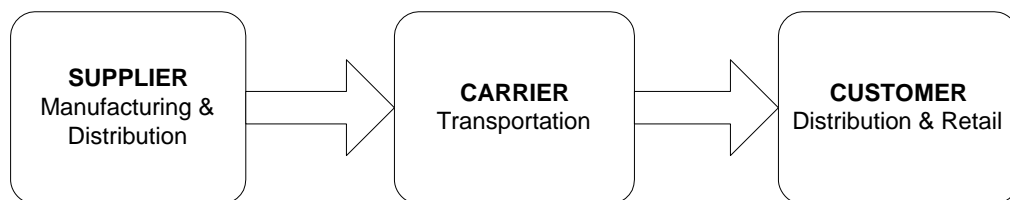
### 6.7.2. Concepts

#### 6.7.2.1. Logistics Information Flow

As a logistic unit moves through the supply chain, a series of events occurs that defines the information related to the unit. The whole supply chain process of manufacturing, finished goods distribution, transportation, and deployment into the marketplace adds layers of information related to the logistic unit.

For example, the physical content of the unit is typically defined at finished goods distribution. At that point in time the identification of the logistic unit as an entity is possible. Other elements of information, such as final destination or the composition of a multi-unit shipment, are not typically known until later in the supply chain process. In a trading relationship, different elements of information are generally known and applied by the supplier, carrier, and customer.

Figure 6.7.2.1 - 1



#### 6.7.2.2. Representation of Information

The information included on a GS1 logistics label comes in two basic forms. Human Readable Interpretation is used by people and is comprised of text and graphics. Machine readable information is designed for data capture by a machine. Bar code symbols are machine readable and are a secure

and efficient method for conveying structured data, while Human Readable Interpretation allows people general access to basic information at any point in the supply chain. Both methods add value to GS1 logistics labels, and often co-exist on the same label.

The GS1 logistics label has three sections. The top section of the label contains free format information. The middle section contains text information and the Human Readable Interpretation of the bar code symbol(s). The lowest section contains the bar code symbol(s).

### **6.7.3. Label Design**

The layout of the GS1 logistics label groups information into three logical sections for the supplier, customer, and carrier. Each label section may be applied at a different point in time as relevant information becomes known. Additionally, within each section, bar code symbols are segregated from text information to facilitate interpretation by both machines and people.

The labeller, the organisation responsible for printing and applying the label, determines the content, format, and dimensions of the label. The SSCC is the single mandatory element for all GS1 logistics labels. Other information, when required, should comply with the specifications of this document and with the proper use of Application Identifiers.

#### **6.7.3.1. Supplier, Customer, Carrier Sections**

A section is a logical grouping of information that is generally known at a particular time. There are three label sections on a GS1 logistics label, each representing a group of information. Generally, the order of the sections, from top to bottom, is: carrier, customer, and supplier. However, this order and top/down alignment may vary depending on the size of the logistic unit and the business process being served.

##### **6.7.3.1.1. Supplier Section**

The supplier section of the label contains information that is generally known at the time of packaging by the supplier. The SSCC is applied here as the unit identifier, along with the Global Trade Item Number (GTIN) if used.

Other information that may be of interest to the supplier but might also be useful for customers and carriers can be applied. This includes product-related information such as product variant; dates such as production, packaging, expiration, and best-before dates; and lot, batch, and serial numbers.

##### **6.7.3.1.2. Customer Section**

The customer section of the label contains information that is generally known at the time of order and order processing by the supplier. Typical information includes the ship to location, purchase order number, and customer-specific routing and handling information.

##### **6.7.3.1.3. Carrier Section**

The carrier section of the label contains information that is generally known at the time of shipment and is typically related to transport. Typical information includes ship to postal codes, AI (420), Consignment Numbers, AI (401), and carrier-specific routing and handling information.

#### **6.7.3.2. Bar Code Symbol and Human Readable Interpretation Layout**

Bar code symbols are represented in the lower part of each section, while Human Readable Interpretation is shown in the upper part of the section. This facilitates access to each component.

Figure 6.7.3.2 - 1



### 6.7.3.3. Label Dimensions

The physical dimensions of the label are determined by the labeller, but the size of the label should be consistent with the data requirements for all sections of the label. Factors influencing label dimensions include the amount of data required, the content and X-dimension of the bar code symbols used, and the dimensions of the logistic unit to be labelled. The business requirements for most users of GS1 Logistic Labels are met by using one of following:

- A6 (105 mm x 148 mm), which is particularly suitable when only the SSCC, or the SSCC and limited additional data, is encoded
- 4 x 6 inch, which is particularly suitable when only the SSCC, or the SSCC and limited additional data, is encoded

-or-

- A5 (148 mm x 210 mm)
- 6 x 8 inch

### 6.7.4. Technical Specifications

#### 6.7.4.1. Bar Code Symbols

##### 6.7.4.1.1. Orientation and Placement

Picket fence orientation bar code symbols should be used on logistic units. In other words, the bars and spaces shall be perpendicular to the base on which the logistic unit stands. In all cases, the GS1-128 Bar Code Symbol encoding the SSCC shall be placed in the lowest portion of the label.

##### 6.7.4.1.2. Human Readable Interpretation

As a back up key entry and diagnostic aid, a Human Readable Interpretation of each bar code symbol shall be provided above or below the symbol. It includes Application Identifiers (AIs), data content, and a Check Digit, but no representation of special symbol characters or the Symbol Check Character.

To facilitate key entry, AIs should be set apart from the data by parentheses.

This Human Readable Interpretation characters shall be no less than 3 millimetres high and clearly legible and preferably below the symbol.

## 6.7.4.2. Text

### 6.7.4.2.1. Plain Text

Text that has no bar code symbol equivalent is often required on a label. The name and address of the sender and receiver are typical examples. In many instances companies may also wish to add specific text to a label (e.g., company logos). All text shall be clearly legible and no less than 3 millimetres high.

### 6.7.4.2.2. Human Readable Interpretation

Human Readable Interpretation is text designed to support manual operations and to facilitate key entry in menu driven systems. It is the equivalent of data elements represented in bar code symbols and is comprised of data titles and data content. The data content should be at least 7 millimetres in height. If there is no language agreed between trading partners, data titles must be printed in English. As an option left at the discretion of the labeller, a second language can be added. Application Identifiers are not included in Human Readable Interpretation.

### 6.7.4.2.3. Data Titles

Data titles are the standard abbreviated descriptions of data fields used to denote the Human Readable Interpretation of encoded data. They are prefixes of the Human Readable Interpretation to support manual interpretation of data fields. They can also be used adjacent to other text or bar code symbols to clarify content, such as the word “from” adjacent to a sender’s address.

All data titles are shown in Section 3.2.

### 6.7.4.3. Label Location

Label placement specifications are maintained in Section 6.6.

## 6.7.5. Label Examples

Figure 6.7.5 - 1 The Basic Label: An SSCC



Figure 6.7.5 - 2 Label with Supplier and Carrier Sections

<p><b>Von/From</b></p> <p><b>Mustermann GmbH</b>  <b>Herr Schmidt</b>  <b>Hauptstr. 35</b>  <b>60100 Frankfurt</b>  <b>Germany</b></p>	<p><b>An/To</b></p> <p><b>Edificio de Servicios</b>  <b>Generales</b>  <b>Ms Alicia Romero</b>  <b>Calle Centella 18</b>  <b>08820 Barcelona</b>  <b>Spain</b></p>
<p><b>SSCC: 353708431300012501</b></p> <p><b>Route: 72408820+04000002</b></p> <p>Dimensions/Weight: 80x20x20 cm / 50,0 kg</p> <p>Billing No.: 5020613963 69 01 <b>001/999</b></p>	
 <p>(403) 72408820+04000002</p>  <p>(00) 3 5370834 130001250 1</p>	

Figure 6.7.5 - 3 Label with Supplier and Carrier Sections

<b>FROM</b> BIG SUPPLIER 5 <sup>th</sup> AVENUE NEW YORK USA	<b>TO</b> GREAT VALUE 8163 NEW CAJUN DAYTON, OHIO USA
 ( 420) 45458	<b>SHIP TO POST</b> 45458 <b>B/L</b> 853930 <b>PRO</b> 2895769860
<b>SSCC</b> 0 0614141 123456789 0  ( 00) 006141411234567890	

Figure 6.7.5 - 4 Label with Supplier Section with Concatenated Data

**GRAND SUPPLIER COFFEE**

---

**SSCC**

0 0614141 1234567890

<b>CONTENT</b>	<b>COUNT</b>
00614141000418	20
<b>BEST BEFORE (ddmmyy)</b>	<b>BATCH</b>
14.02.00	4512XA

---

(02)00614141000418(15)000214(10)4512XA(37)20

( 00 ) 0 0 6 1 4 1 4 1 1 2 3 4 5 6 7 8 9 0

Figure 6.7.5 - 5 Labels with Supplier, Customer, and Carrier Sections



### 6.7.6. EPCglobal Seal Application Guidelines

If using EPC Tags on products it is important to make supply chain partners aware of their presence. This is achieved by using the latest version of the EPCglobal Seal that can be found on: <http://www.epcglobalinc.org/standards/tds/>.

### 6.8. Placement Labels Used in General Distribution

General Distribution Scanning items include any item handled as a single unit in the transport and distribution process. This definition covers a wide variety of package types, such as pallets, cartons, cases, bins, and totes. These items can be trade items and/or logistic units.

Bar code scanning may be carried out manually or automatically, and the recommended symbol location cannot be optimised for one or the other in an open supply chain scenario. These guidelines have been prepared with the objective to reduce overall supply chain cost but in the full knowledge that implementation will only be driven by a proven (supply chain) business-case.

### 6.8.1. General Rule

The bar codes on units intended for General Distribution should be upright (i.e. in picket fence orientation) and placed on the sides of the unit. Each item shall have at least one bar code, and two are recommended when these symbols are pre-printed (see Section 6.8.3).

As not all products are packed in an identical way, this general rule may not apply to unusual packaging types (e.g., low height items, display cases, bags).

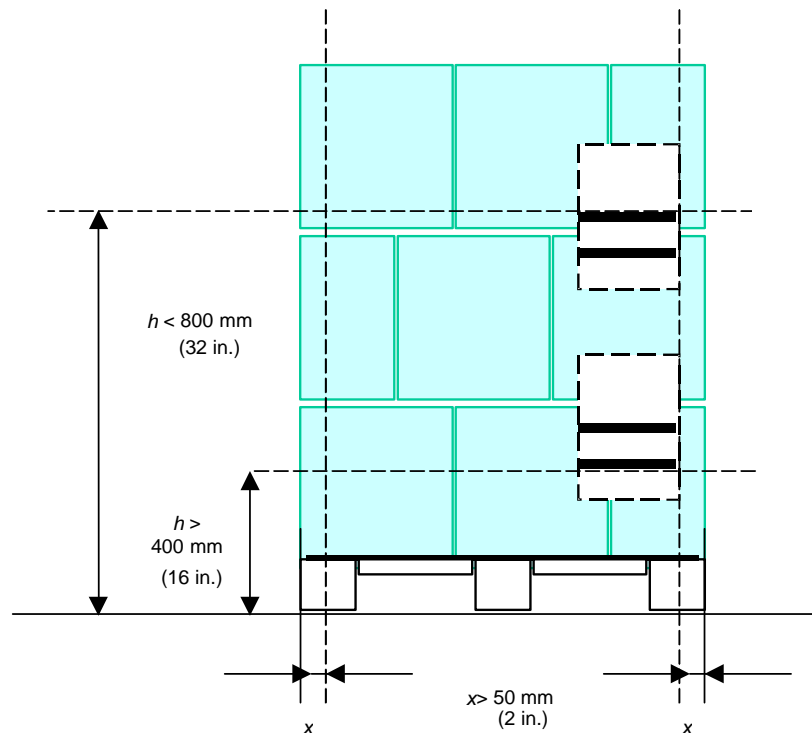
The bar codes should be kept away from any vertical edges so that the bar codes are less likely to be accidentally damaged in transit.

#### 6.8.1.1. Symbol Placement on Pallets

For all types of pallets, including full pallets containing individual trade items and single trade items, (such as a refrigerator or washing machine), the target height for the bottom of the bar code symbol is between 400 millimetres (16 inches) and 800 millimetres (32 inches) from the base of the pallet. For pallet less than 400 millimetres (16 inches) high, the bar code symbol should be placed as high as possible while protecting the bar code.

The symbol including, its Quiet Zones, should be at least 50 millimetres (2.0 inches) from any vertical edge to avoid damage.

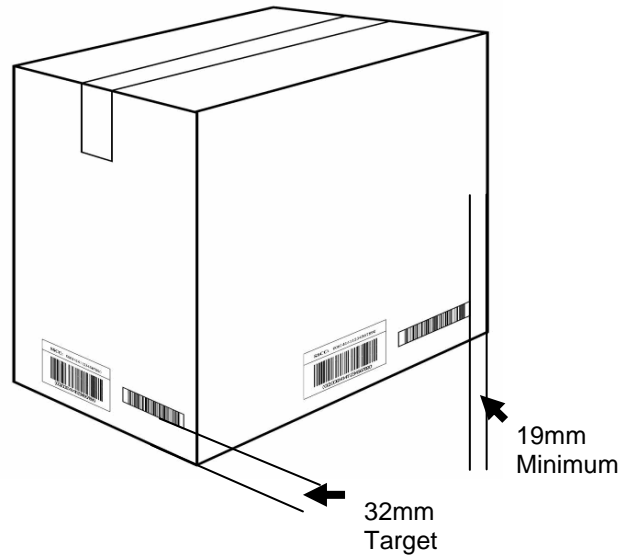
Figure 6.8.1.1 - 1 Symbol Placement on a Pallet



#### 6.8.1.2. Symbol Placement on Cartons and Outer Cases

For cartons and outer cases, symbol placement will vary slightly in practice, however the target placement for the bottom of the bar code symbol is 32 millimetres (1.25 inches) from the natural base of the item. The symbol including, its Quiet Zones, should be at least 19 millimetres (0.75 inch) from any vertical edge to avoid damage.

**Figure 6.8.1.2 - 1 Symbol Placement on Cartons and Outer Cases**

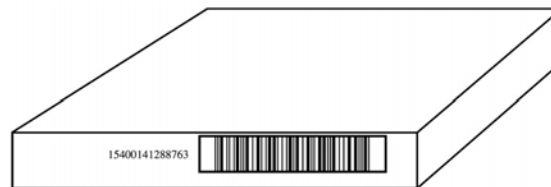


**6.8.1.3. Symbol Location on Shallow Trays and Cases**

If the height of a case or tray is less than 50 millimetres (2.0 inches), making it impossible to print a full height bar code with the Human Readable Interpretation below the bars, or if the construction of the unit is such that the full symbol height cannot be accommodated, the following options should be considered in this order of preference:

- 7. Place the Human Readable Interpretation to the left of the symbol, outside the compulsory Quiet Zones.

**Figure 6.8.1.3 - 1 Human Readable Text to Left of Symbol**



- 8. When the height of the unit is less than 32 millimetres, the symbol may be placed on the top of the package. The symbol should be placed with the bars perpendicular to the shortest side, no closer than 19 millimetres (0.75 inch) from any edge.

**Figure 6.8.1.3 - 2**



Sometimes two bar code symbols are used on variable measure units. If it is necessary to remove the Human Readable Interpretation from beneath the unit, the human readable characters of the main symbols should be placed to the left of the bars of the main symbol. The Human Readable Interpretation of the Add-On Symbol should be placed to the right of the bars of the Add-On Symbol.

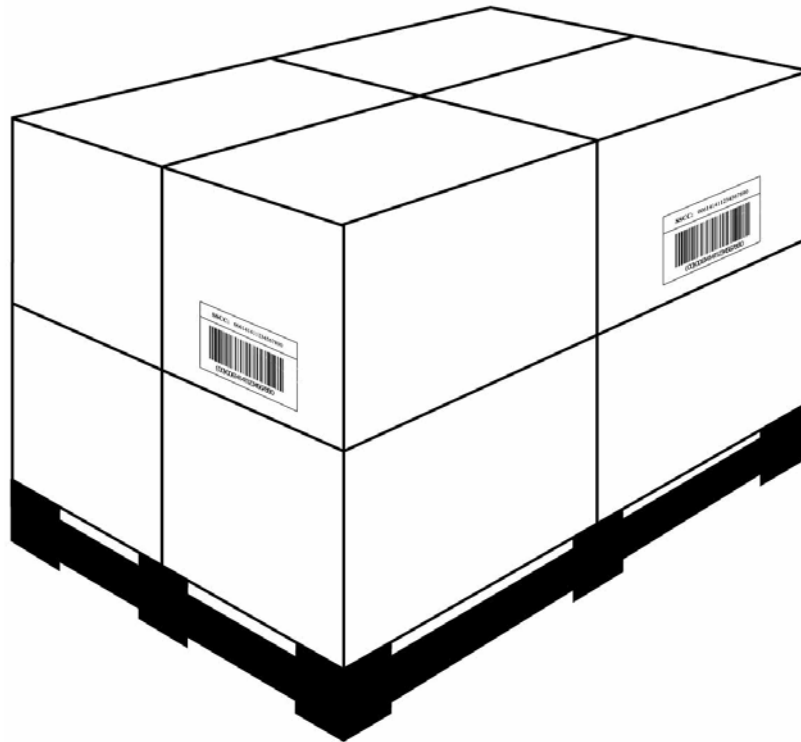
### 6.8.2. Recommendation to Include a Bar Code on Two Sides

Although at least one side of all General Distribution Scanning items shall display the bar code information, it is recommended that two (or more) sides of the item carry a bar code symbol with the exact same data when:

- The printing process makes this cost effective (e.g. pre-printed corrugated cartons).
- The supply chain requirement is that one symbol is always visible (e.g., pallets that are stored either long or short edge facing).

**Figure 6.8.2 - 1 Two (or More) Identical Bar Code Symbols**

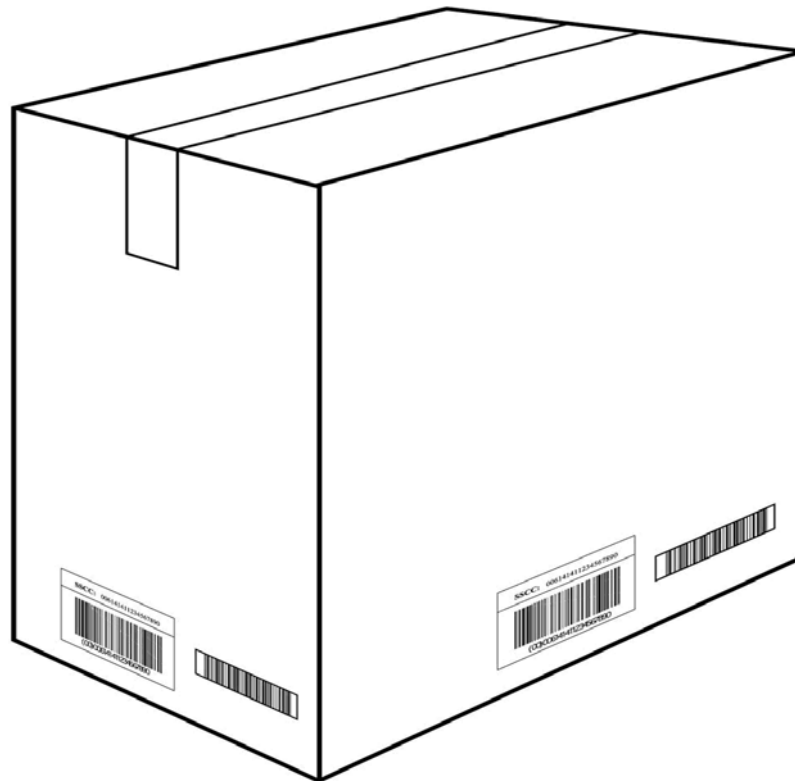
Two identical labels improves scanning performance



### 6.8.3. Add-On Symbols

If the unit is already marked with a symbol, any Add-On Symbol shall be placed so as not to obscure the primary bar code symbol. The preferred location for the symbol in this case is to the side of the primary bar code symbol so that a consistent horizontal location is maintained. Maintain Quiet Zones for both symbols.

Figure 6.8.3 - 1



If there is the potential for both parts of the data content to be represented in a GS1-128 Bar Code Symbol, they should be concatenated and one symbol produced. Bar code symbols containing data essential for complete product identification (e.g., trade measurements) should always be aligned with and to the right of the bar code symbol containing the Global Trade Item Number (GTIN) (the primary symbol).



## Section 7. AIDC Validation Rules

- Introduction
- Synopsis of Message Processing
- Validation of the Electronic Message Regarding System Consistency
- Validation of the Electronic Message Regarding User Requirements
- Conversion of Weights and Measures in User Applications
- Linkage of GTINs in a Database
- Elements Strings Represented in Data Carriers
- Secondary Data for specific Health Industry Products
- Processing of Data from a GS1 Symbology using GS1 Application Identifiers
- Check Digit Calculations
- GTIN-12 and RCN-12 in a UPC-E Bar Code Symbol
- The International Standard ISO/IEC 646
- Determination of Century in Dates

Whilst every effort has been made to ensure that the guidelines to use the GS1 standards contained in the document are correct, GS1 and any other party involved in the creation of the document HEREBY STATE that the document is provided without warranty, either expressed or implied, of accuracy or fitness for purpose, AND HEREBY DISCLAIM any liability, direct or indirect, for damages or loss relating to the use of the document. The document may be modified, subject to developments in technology, changes to the standards, or new legal requirements.

Several products and company names mentioned herein may be trademarks and/or registered trademarks of their respective companies.

## 7.1. Introduction

The purpose of entering data transmitted from a reading device into a system is to record a transaction. In the GS1 System, a transaction is an Electronic Message to be processed according to the meaning and content of the data fields contained in the message. This should be possible without requiring any human intervention to determine the data's meaning and content.

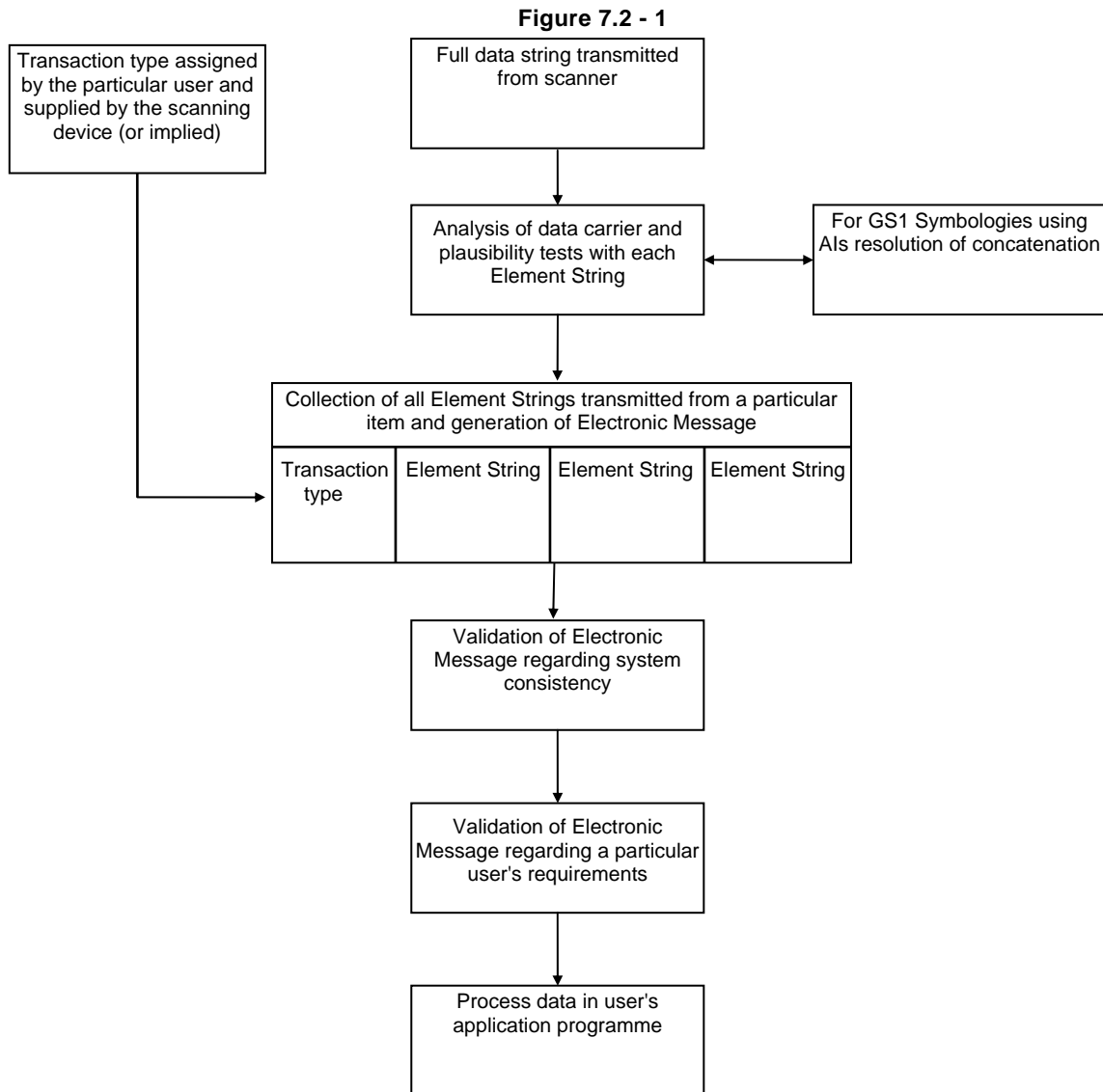
First, an item must be physically present in order to produce a bar code or RFID reader message about the item. Only the data present in the data carrier on the item, and therefore relevant to it, can be recorded.

The standardised Element Strings of the GS1 System are the basis for the identification of items of every kind. They identify a particular item in an unambiguous manner and supply relevant attribute information.

When these Element Strings are printed on items, the scanned and transmitted data refers to that item and identifies its physical presence at a given location. When the message read from the scanned data carrier is coupled with an internally assigned designation of the type of item movement (e.g., warehouse entry, stock taking, sales), it is possible to automatically record data related to each movement of items. This provides security in two ways. First, an item must be physically present in order to produce a bar code reader message about the item, and, second, only the data in the bar code on the item and, therefore, relevant to it, can be recorded. False notification of movements is thereby largely eliminated.

When Element Strings are used in administrative areas (e.g., in order entry) they also can be used for automatic, error-free data capture. Because of the considerable length of many GS1 System ID numbers, automatic reading has great significance. By using a Check Digit, a digit that ensures the data has been correctly composed, the accuracy of the reading can be verified.

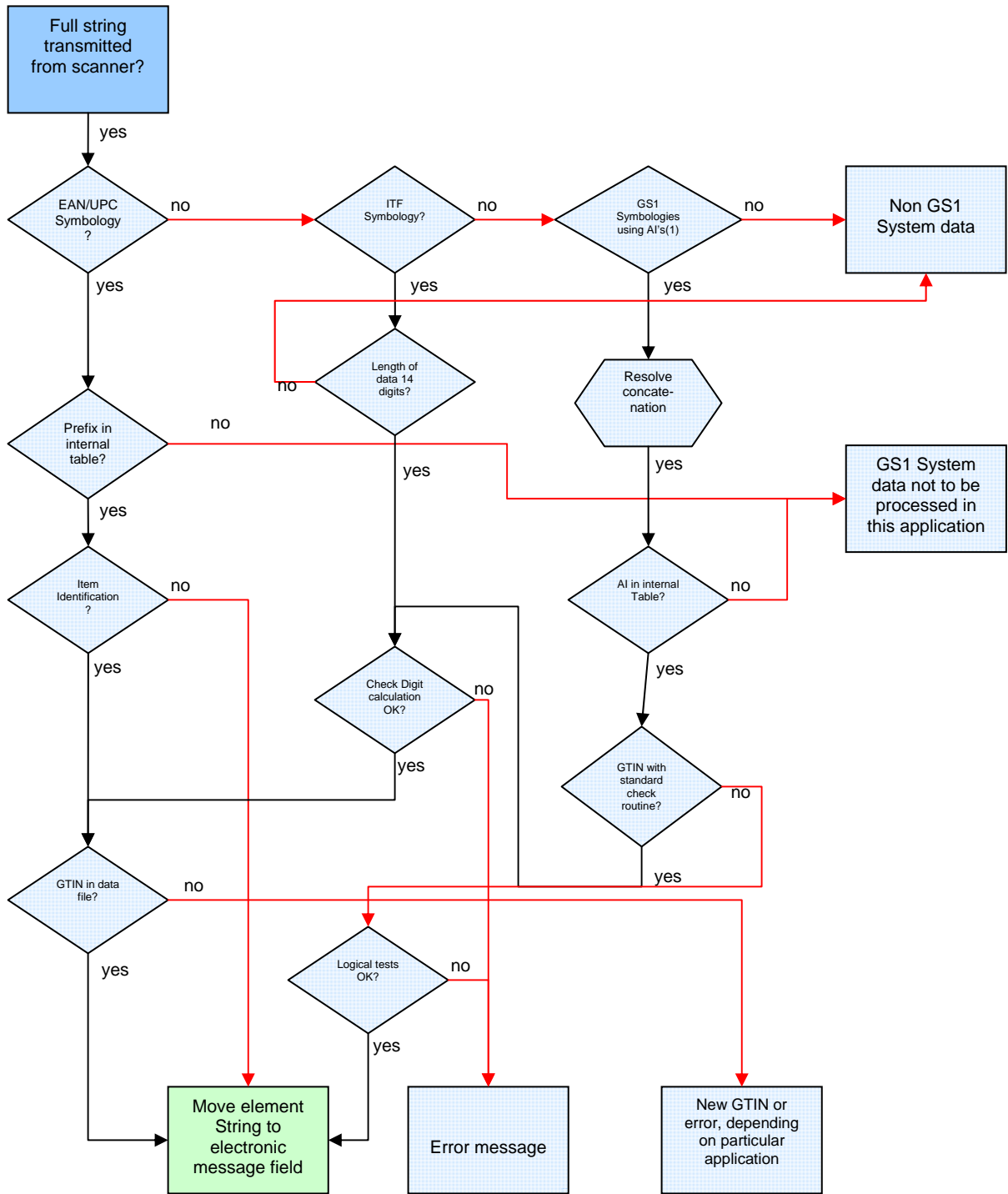
## 7.2. Synopsis of Message Processing



For details on any of the actions in Figure 7.2 - 1, see the following subsections.

### 7.2.1. Analysis of the Data Carrier and Plausibility Test for Element Strings

Figure 7.2.1 - 1



(1) GS1 Symbologies that encode data using GS1 Application Identifiers include GS1-128, GS1 DataMatrix GS1 DataBar and Composite and are shown in 7.9. For further details on any of the actions in Figure 7.2.1 - 1, see the sections 7.2.2, 7.2.3, 7.2.4, 7.2.5, 7.2.6, 7.2.7, and 7.2.8.

### 7.2.2. Symbology Identification

Each transmitted full string consists of a symbology identifier and one or more Element Strings (see Section 3). The identifiers of bar code symbologies are stated in Section 5.

### 7.2.3. Prefix in Internal Table

System users may generate an internal table showing the GS1 Prefixes of Element Strings they wish to process. This table also serves to sort out the Element Strings representing item identification numbers in order to check their presence in the data file. Details on the respective prefixes are stated in Section 3.

### 7.2.4. Item Identification

The symbols in the EAN/UPC Symbology family contain identification data for trade items and special data structures (e.g., coupons). Whether an Element String contains the identification of a trade item is determined by the GS1 Prefix. System users must determine the specific structure and meaning of prefixes 20 to 29 as defined by their GS1 Member Organisation.

### 7.2.5. Application Identifier (AI) in Internal Table

The Element Strings using Application Identifiers cover a wide range of applications. In order to keep the amount of programming on a reasonable level, it is possible to ignore processing of unwanted Element Strings. This is achieved by establishing an internal table with only the Application Identifiers intended for processing.

### 7.2.6. Length of Data 14 Digits

ITF-14 Bar Code Symbols are used to represent trade item identification numbers. As the use of the general ITF symbology is not exclusive to the GS1 System a check to ensure the symbol encodes 14-digit reference field is recommended.

### 7.2.7. Check Digit Calculation and other system checks

In EAN/UPC Symbology, the Check Digit verifies reading and decoding of bar code symbols as well as Global Trade Item Numbers (GTINs). This is performed automatically by the bar code reader.

Bar code readers processing ITF-14 Symbols may be programmed to verify the GTIN's Check Digit as well. If this recommended verification has been performed, it is indicated by the symbology identifier ] | 1 (see Section 5). For data transmitted from ITF-14 Symbols with symbology identifier ] | 0, the GTIN's Check Digit should be verified separately.

GS1-128 and GS1 DataBar have an integral Symbol Check Character that verifies correct decoding of scanned data while GS1 DataMatrix has a Reed Solomon error checking and correction feature. If an Element String encoded in one of these symbol types includes a Check Digit, the Check Digit will not normally be verified by the bar code reader and should be verified separately. While the data security provided by the Symbol Check Character or error checking guarantees proper decoding of the entire Element String, correctness of the contained identification number is achieved by having the application software verify the ID number's Check Digit.

Other logical tests checks are recommended for reasonable data content, such as verifying:

- Data field ranges (e.g., month < 13 and > 00)
- The maximum length of a variable length Element String
- No alphanumeric characters in numeric only fields
- Correct GS1 Prefixes

### 7.2.8. Move Element String to Message Field

Several Element Strings may be scanned in a single transaction. In order to verify the correctness and completeness of the transmitted data, each Element String is transferred to a message record. If an Element String does not include an Application Identifier, verification of the message is simplified if an Application Identifier is internally assigned. Global Trade Item Numbers (GTINs) that are carried by EAN-13, UPC-A, UPC-E or ITF-14 Bar Code Symbols may be denoted with an internally assigned AI (01). Other Element Strings may be assigned "ghost" Application Identifiers.

## 7.3. Validation of the Electronic Message Regarding System Consistency

The GS1 System enables system users to process scanned data without human intervention. This implies that the electronic message generated from data scanned and transmitted from data carriers needs to substitute for all human activities during a particular transaction. In other words, the transmitted data must provide all information required for its correct processing.

The GS1 System is designed to fulfill these requirements. Section 4 describes the association of Element Strings to form valid messages.

Validation of system consistency refers to the verification of the correct composition of the electronic message by a system processing the transaction messages. Whether the message is adequate in business application terms is dealt with by the application software.

Only messages containing a valid set of Element Strings defined in the GS1 System can be unambiguously processed. The processing of invalid messages may lead to data file errors because the meaning and relationship of the Element Strings are not defined. This is illustrated in Figures 7.3 - 1 and 7.3 - 2.

**Figure 7.3 - 1 Examples of Valid Messages**

Element Strings in Message			Comment
AI 00	AI 33nn		Identification of a logistic unit + logistic weight
AI 00	AI 01		Identification of an entity as a logistic unit and as a Fixed Measure Trade Item
AI 00	AI 01 '9'	AI 31nn	Identification of an entity as a logistic unit and as a Variable Measure Trade Item
AI 00	AI 02	AI 37	Identification of a logistic unit and its contained Fixed Measure Trade Items
AI 01	AI 10	AI 15	Identification of a trade item + lot number + best before date
AI 00	AI 401		Identification of a logistic unit as part of a consignment
AI 01 '9'	AI 31nn	AI 33nn	Identification of a Variable Measure Trade Item + logistic weight
AI 00	AI 01	AI 33nn	Identification of an entity as a logistic unit and a Fixed Measure Trade Item; the logistic weight is associated with the identification number of the logistic unit

**Figure 7.3 - 2 Examples of Invalid Messages**

Element Strings in Message			Comment
AI 00	AI 01	AI 37	Invalid identification of an entity as a logistic unit and as a Fixed Measure Trade Item; AI 37 (quantity of items contained) must be used with AI 02 only
AI 01	AI 10	AI 33nn	Invalid identification of a Fixed Measure Trade Item + lot number; AI 33nn is incorrect because logistic measures of a Fixed Measure Trade Item are fixed attributes stored in the data file
AI 01'9'	AI 33nn		Invalid identification of a Variable Measure Trade Item + logistic weight; the mandatory Element String with a trade measure is missing
AI 00	AI 11		Invalid identification of a logistic unit; AI 11 is incorrect because a production date must be associated with the identification number of a trade item
AI 00	AI 01	AI 02/37	Invalid identification of an entity as a logistic unit and as a Fixed Measure Trade Item; AI 02/37 must not be associated with AI 01
AI 01	AI 30		Invalid identification of a Fixed Measure Trade Item; AI 30 must only be associated with the identification number of a Variable Measure Trade Item
AI 02	AI 37		Invalid identification of the fixed measure trade units contained in an unidentified logistic unit; AI 00 is missing
AI 00	AI 02		Invalid identification of a logistic unit and of the contained Fixed Measure Trade Items; AI 02 requires the mandatory presence of AI 37 to complete the identification of the content

## 7.4. Validation of the Electronic Message Regarding User Requirements

Some industry groups and organisations specify the use of particular Element Strings for attributes and other information not directly identifying the item. Contrary to the validation of messages for system conformity, GS1 does not define the rules for the validation and application of these particular Element Strings. Validation of messages containing these Element Strings in these environments (e.g., trade item identification with best before date and batch number) is left to the discretion of the particular system user community.

Validation of the correctness of a message may be performed differently for each Global Trade Item Number (GTIN), and instructions must be stored in the data file. System users should include the Application Identifiers and their specific application rules in the stored instructions.

Validation of the user requirements must be performed after validation of system consistency. Missing elements in consistent messages may be by-passed or completed in given instances. Inconsistent messages can never be processed properly.

## 7.5. Conversion of Weights and Measures in User Applications

All weights and measures that are encoded in the Element Strings with the Application Identifiers (31nn) to (36nn) are structured according to the same mathematical rules. The determination of basic units of measurement and the freedom to choose the number of decimal positions will lead to variations in data representation. Suppliers will choose the value that best suits the respective trade item in terms of weight/size and the degree of accuracy required (e.g., grams) for the representation of weights and measures in the six-position data field.

The recipient of such goods also may want to store these details in a standardised form in his data file. This requirement is easily fulfilled through programming with the conversion formula shown below.

As described in Section 3, the Application Identifier in position A<sub>4</sub> denotes the position of the implied decimal point, called the Inverse Exponent.

The three-step formula to convert weights and measures is as follows:

1. Define the company's internal inverse exponent in accordance with the basic unit of measure of the company's internal field structure (e.g., for an AI expressing weight in kilograms, inverse exponent 0 could signify kilograms and inverse exponent 3 could signify grams).
2. Subtract the company's internal inverse exponent from the value of the position A<sub>4</sub> of the Application Identifier in the decoded Element String. Call the result X.
3. Divide the amount of the six-digit applicable value field from the decoded data string by 10<sup>x</sup>. The result is the value required in the company's data structure.

In the examples in Figure 7.5 - 1, the company's system uses internal weight fields eight digits in length (format: **nnnnnnn.n**) with a unit of measure equal to grams. Thus, the company uses the internal inverse exponent of 3.

Figure 7.5 - 1

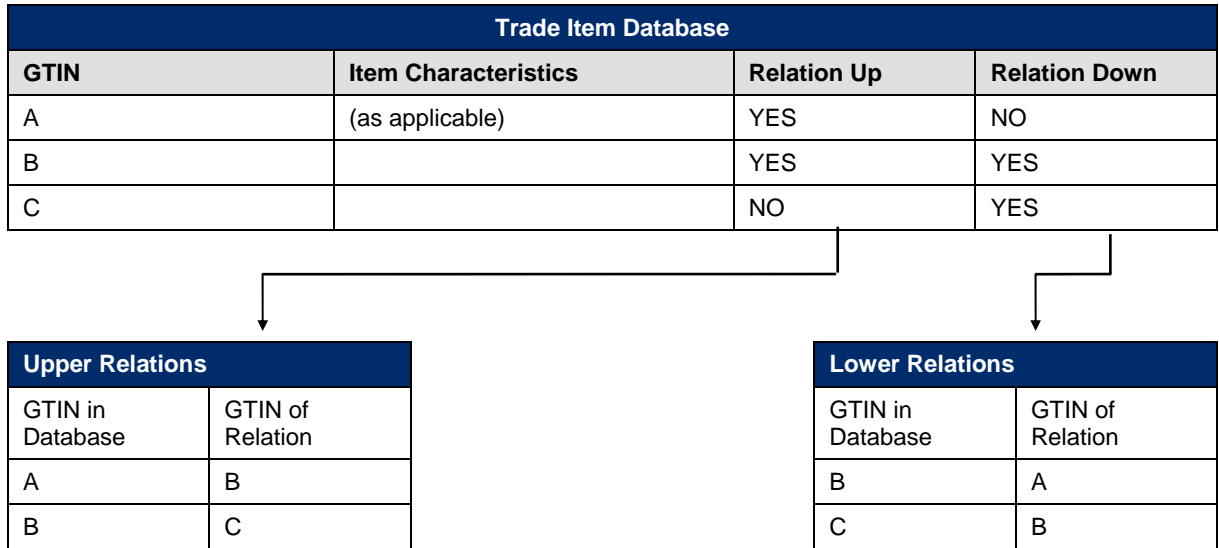
Decoded Data String				Conversion	Internal Weight Field
Application Identifier A <sub>1</sub> A <sub>2</sub> A <sub>3</sub> A <sub>4</sub>	Weight				Eight-Digit Data Field Defined as Grams with One Decimal Position
3   1   0   0	005097 (= 5097 kg)	Step 2: X = 0 minus 3 = -3 Step 3: 005097 divided by 10 <sup>-3</sup> (.001) =	5   0   9   7   0   0   0		
3   1   0   2	005097 (= 50.97 kg)	Step 2: X = 2 minus 3 = -1 Step 3: 005097 divided by 10 <sup>-1</sup> (.1) =	0   0   5   0   9   7   0		
3   1   0   3	045250 (= 45.250 kg)	Step 2: X = 3 minus 3 = 0 Step 3: 045250 divided by 10 <sup>0</sup> (1) =	0   0   4   5   2   5   0		
3   1   0   4	012347 (= 1234.7 g)	Step 2: X = 4 minus 3 = 1 Step 3: 012347 divided by 10 <sup>1</sup> (10) =	0   0   0   1   2   3   4   7	↑ Decimal point	



### 7.6.1. The Principle

The hierarchy for the example in Figure 7.6.1 - 1 is basic product = A; 10 x A = product B; 5 x B = product C.

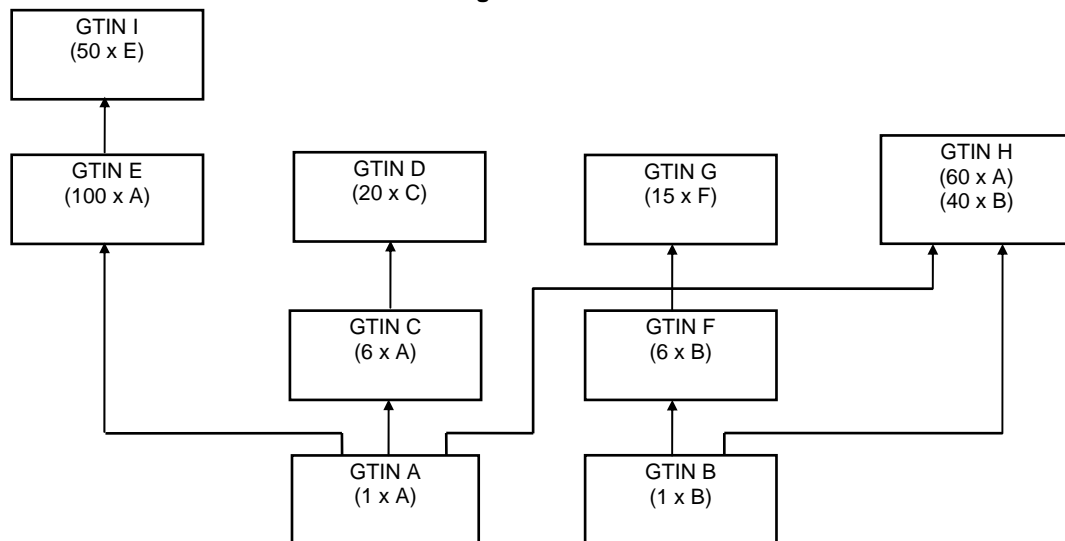
Figure 7.6.1 - 1



See Figure 7.6.2 - 1 for the mechanism of linkage for the various types of trade items.

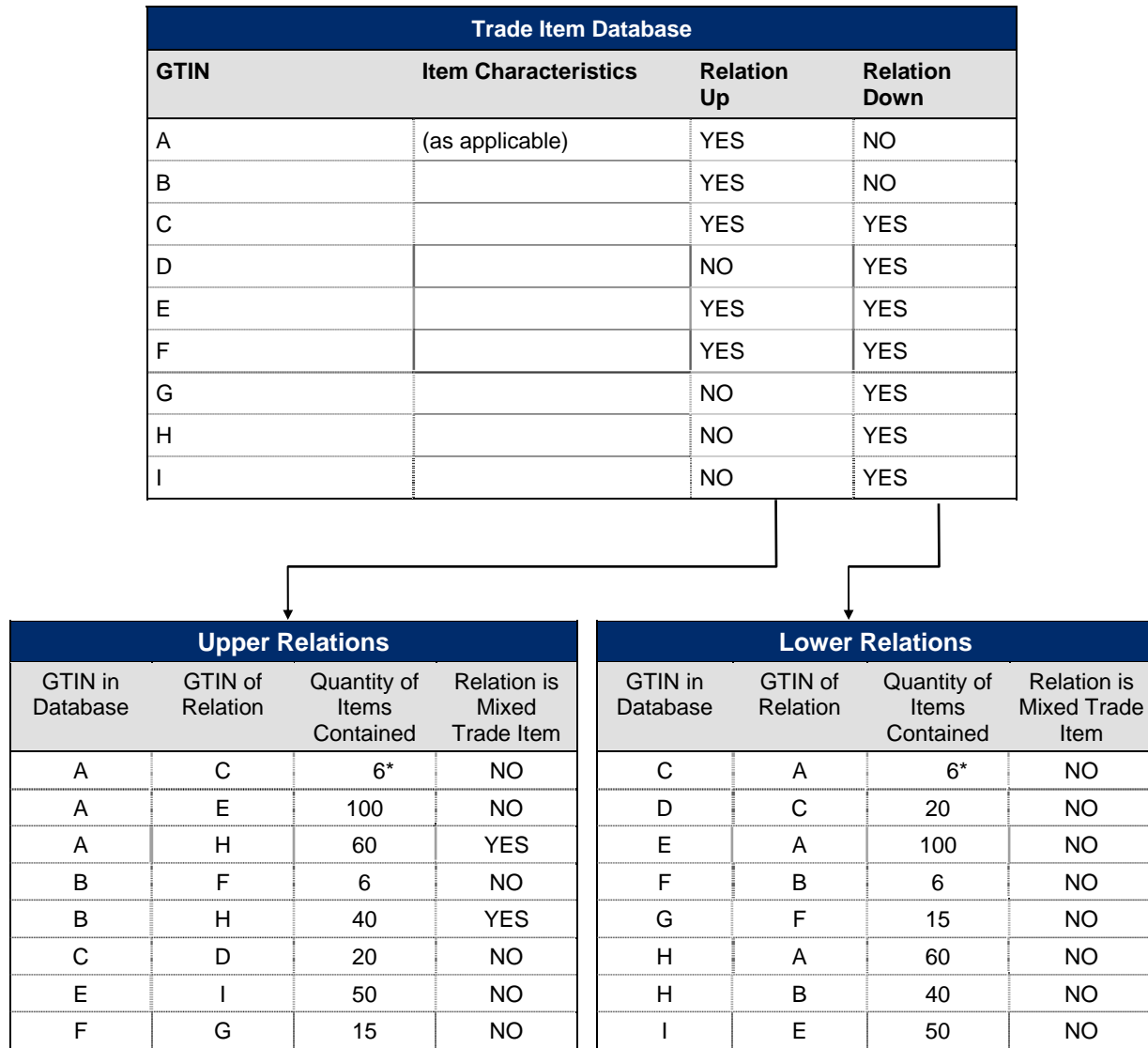
### 7.6.2. Extended Example of a Trade Item Hierarchy

Figure 7.6.2 - 1



**Note:** For reasons of simplicity, Global Trade Item Numbers (GTINs) are expressed in letters in this example, signifying that they may be of any standardised structure.

Figure 7.6.2 – 2



\* Quantity of items numbered A contained in item C



**Note:** The columns "GTIN in Database" and "GTIN of Relation" are sufficient to establish the links between the different items. The column "Quantity of Items Contained" provides additional information, which may be useful in particular business applications. The column "Relation is Mixed Trade Item" provides the relations pointing to all trade items contained in a mixed trade item.

### 7.6.3. Linkage of GTINs in a Non-Relational Database by Trade Item Manufacturer

Many types of items are produced and distributed in fixed measure standard nested packaging configurations (e.g., consumer unit, carton, case, pallet) with fixed quantity relationships. The various packaging configurations are often broken into lower levels at various points in the supply chain, and, therefore, each level of the packaging may be a trade item. Computer systems must be capable of

understanding the relationships of the units or trade items in the configuration and treating inventory of all levels of the configuration as one SKU (stock keeping unit).

The first digit Indicator (values 1 to 8) of the GTIN-14 Data Structure can be used to identify levels of a standard packaging configuration. This allows digits 2 to 13 to remain constant for all levels of the standard packaging configurations for an item. If this method of numbering item configurations is used when necessary to support business processes or when driven by system constraints, the non-relational database construct defined below may be appropriate.

The item database is constructed with a base item record (table) and segments (tables) for each level of the item packaging configuration. Properly designed, this type of system can support pricing, ordering, and shipping of any level of the packaging configuration (trade item) with appropriate dimension and weight information. It enables inventories to be maintained by packaging level and in total for the base item. It also provides channel partners or customers the choice of ordering and invoicing units. Meeting these requirements often makes this approach a good business solution for manufacturers, because it meets the most critical needs in the supply chain and is practical to implement, particularly in distributed and small systems where performance is critical.

Using the GTIN-14 Data Structure, the base item record contains the base GTIN-8, GTIN-12, or GTIN-13 ID Number (digits 2 to 13) as a key, with all information relating to the base unit and the item in total (including total inventory balance). Each of the packaging segments contains information unique to the respective packaging configuration (e.g., Indicator, Check Digit, quantity relationship to next lower level of the configuration, dimensions, weight, prices). After accessing the item record using the GTIN of the base item (digits 2 to 13), the packaging segments are accessed using the Indicator (first digit).

This construct demands that:

- The trade item must be fixed in measure.
- There must be a single Global Trade Item Number (GTIN) for the base item of the related packaging configurations that is a GTIN-8, GTIN-12, or GTIN-13.
- Each related packaging configuration is limited to eight levels of packaging for the base item using Indicator values 1 to 8.

When storing GTIN-8s, GTIN-12s, or GTIN-13s in a 14-digit reference field or 14-digit data carrier, they must be stored based on rules that ensure their uniqueness.

Companies that receive trade items with GTINs must be able to process the complete GTIN without regard to how it was constructed.

## 7.7. Elements Strings Represented in Data Carriers

Scanned Element Strings are decoded as a full string by the reading device and are then transmitted for processing in the application software. The full string is composed of a symbology identifier and one or more Element Strings. The meaning of an Element String is also determined by the data carrier in which it is represented.

A synopsis by data carrier of the Element Strings described in these specifications is shown in Figure 7.7.1 - 1, which also provides an overview of the sequential number range of trade items by data carrier.

### 7.7.1. Element Strings Represented in GS1 System Data Carriers

Figure 7.7.1 - 1

ITF-14 or GS1-128 Bar Code Symbol													
EAN-13 Bar Code Symbol													
UPC-A or UPC-E Bar Code Symbol													
										EAN-8 Bar Code Symbol			
2.	*	*	*	*	*	*	0	0	0	0	0	0	C
							0	9	9	9	9	9	C
1.	*	*	*	*	*	*	1	0	0	0	0	0	C
							1	3	9	9	9	9	C
2.	*	*	*	*	*	*	2	0	0	0	0	0	C
							2	9	9	9	9	9	C
1.	*	*	*	*	*	*	3	0	0	0	0	0	C
							9	6	9	9	9	9	C
1.	0	0	0	0	0	1	0	0	0	0	0	0	C
	0	0	0	0	0	9	9	9	9	9	9	9	C
2.	*	*	0	0	1	0	0	0	0	0	0	0	C
			0	0	7	9	9	9	9	9	9	9	C
1.	0	0	0	0	8	0	0	0	0	0	0	0	C
	0	0	1	9	9	9	9	9	9	9	9	9	C
4.	*	0	2	0	0	0	0	0	0	0	0	0	C
	0	0	2	9	9	9	9	9	9	9	9	9	C
1.	0	0	3	0	0	0	0	0	0	0	0	0	C
	0	0	3	9	9	9	9	9	9	9	9	9	C
2.	*	0	4	0	0	0	0	0	0	0	0	0	C
	0	0	4	9	9	9	9	9	9	9	9	9	C
5.	*	0	5	0	0	0	0	0	0	0	0	0	C
	0	0	5	9	9	9	9	9	9	9	9	9	C
1.	0	0	6	0	0	0	0	0	0	0	0	0	C
	0	0	9	9	9	9	9	9	9	9	9	9	C
1.	0	1	0	0	0	0	0	0	0	0	0	0	C
	0	1	3	9	9	9	9	9	9	9	9	9	C
2. 4.	*	2	0	0	0	0	0	0	0	0	0	0	C
	*	2	9	9	9	9	9	9	9	9	9	9	C
1.	0	3	0	0	0	0	0	0	0	0	0	0	C
	0	9	6	9	9	9	9	9	9	9	9	9	C
7.	*	9	7	7	0	0	0	0	0	0	0	0	C
		9	7	9	9	9	9	9	9	9	9	9	C
8.	*	9	7	8	0	0	0	0	0	0	0	0	C
	*	9	7	9	9	9	9	9	9	9	9	9	C
5. 6.	*	9	8	0	0	0	0	0	0	0	0	0	C
		9	8	2	9	9	9	9	9	9	9	9	C
5.	*	9	9	0	0	0	0	0	0	0	0	0	C
		9	9	9	9	9	9	9	9	9	9	9	C
1.	1	0	0	0	0	0	1	0	0	0	0	0	C
	8	0	0	0	0	0	1	3	9	9	9	9	C
1.	1	0	0	0	0	0	3	0	0	0	0	0	C
	8	0	0	0	0	0	9	6	9	9	9	9	C
1. 3.	1	0	0	0	0	1	0	0	0	0	0	0	C
	9	0	0	0	0	9	9	9	9	9	9	9	C
1. 3.	1	0	0	0	9	0	0	0	0	0	0	0	C
	9	0	1	9	9	9	9	9	9	9	9	9	C
1. 3.	1	0	3	0	0	0	0	0	0	0	0	0	C
	9	0	3	9	9	9	9	9	9	9	9	9	C
1. 3.	1	0	6	0	0	0	0	0	0	0	0	0	C
	9	0	9	9	9	9	9	9	9	9	9	9	C
1. 3.	1	1	0	0	0	0	0	0	0	0	0	0	C
	9	1	3	9	9	9	9	9	9	9	9	9	C
1. 3.	1	3	0	0	0	0	0	0	0	0	0	0	C
	9	9	6	9	9	9	9	9	9	9	9	9	C
8.	1	9	7	8	0	0	0	0	0	0	0	0	C
	8	9	7	9	9	9	9	9	9	9	9	9	C

1. Fixed measure; 2. Fixed measure restricted distribution; 3. Variable measure; 4. Variable measure restricted distribution (not a GTIN); 5. Coupons (not a GTIN); 6. Refund Receipts (not a GTIN); 7. ISSN; 8. ISBN

### 7.7.2. Element Strings Represented in a GS1 Symbology using GS1 Application Identifiers

The Element Strings encoded in any GS1 Symbology that uses GS1 Application Identifiers (such as GS1-128, GS1 DataMatrix, GS1 DataBar and Composite) are composed of one or more GS1 Application Identifiers and one or several data fields. The Application Identifier denotes the contents and structure of the respective data fields. Full details are contained in Section 3.

## 7.8. Secondary Data for specific Health Industry Products

Figures 7.8 - 1 and 7.8 - 2 show the correct data formats for secondary data for specific health industry products. If a column in Figure 7.8 - 3 is left blank, then that data format information is not used.

**Figure 7.8 - 1**

Format	Description
MM	two-digit expiration date month indicator (fixed length of two numeric digits)
YY	two-digit expiration date year indicator (fixed length of two numeric digits)
DD	two-digit expiration date day indicator (fixed length of two numeric digits)
HH	two-digit expiration date hour indicator (fixed length of two, G.M.T. format)
JJJ	three-digit expiration date Julian day indicator (fixed length of three numeric digits)
LOT	up to 13-digit alphanumeric lot number
L	1-digit link character (GTIN Check Digit)
QQ	two-digit quantity (fixed length of two numeric digits)
QQQQQ	five-digit quantity (fixed length of five numeric digits)

The data in Figure 7.8 - 2 is used in the example in Figure 7.8 - 3.

**Figure 7.8 - 2**

GTIN	10312345678903
Lot number	3C001
Link character	3
Expiration date	September 28, 1995, at 10 p.m.
Two-digit quantity	24
Five-digit quantity	00100

Quantity represents the quantity of items contained within the trade item where the inside item is assigned the GTIN **00312345678906**.

The data formats in Figure 7.8 - 3 show all combinations of the sub-fields possible within the Element String.

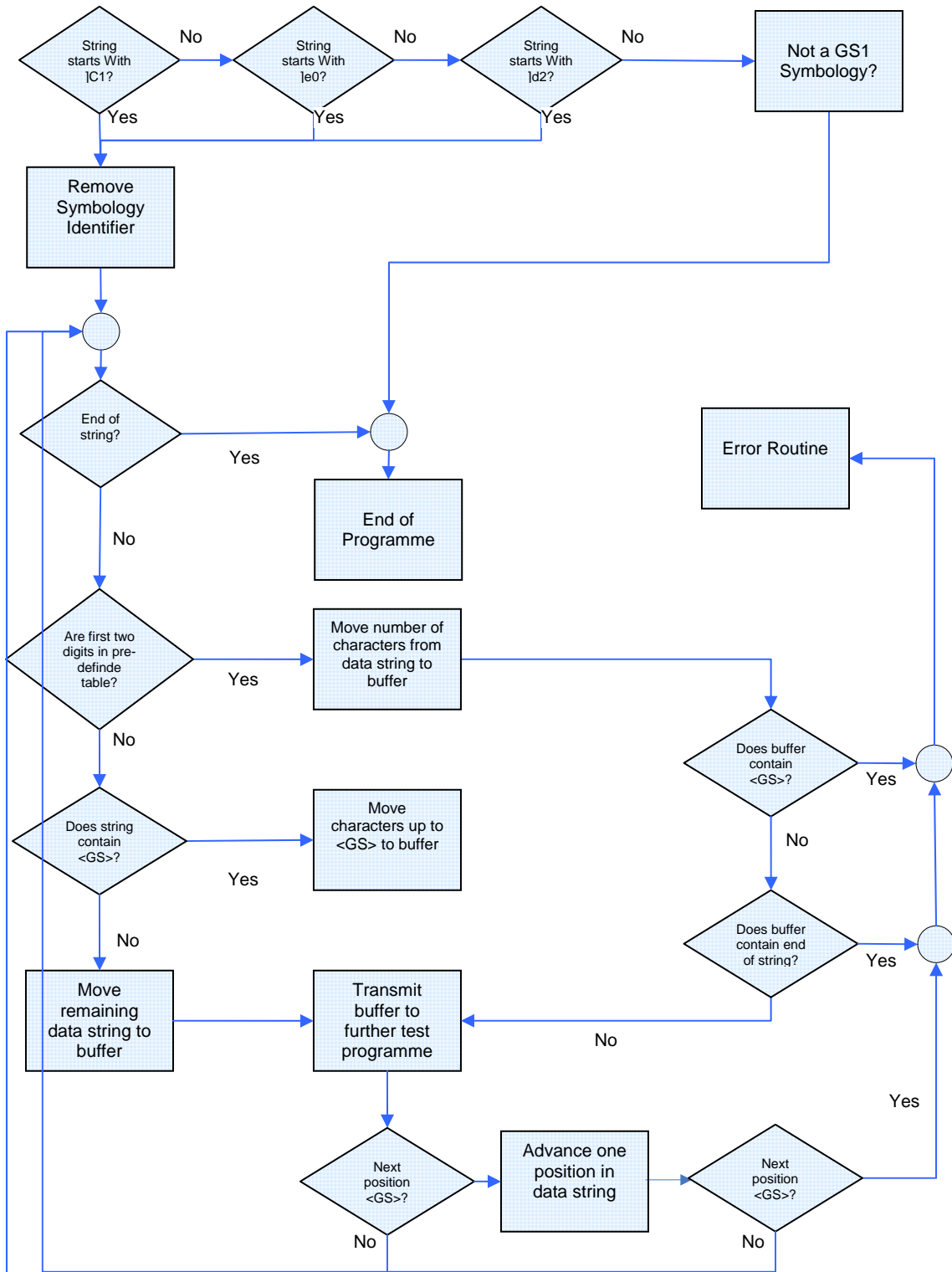
Figure 7.8 - 3

Row	Application Identifier	Quantity Format Digit	Quantity Format	Expiration Date Format Digit	Expiration Date Format	Lot Field	Link Digit	Example Data
1	22				MMYY	LOT	L	2209953C0013
2	22			2	MMDDYY	LOT	L	2220928953C0013
3	22			3	YYMMDD	LOT	L	2239509283C0013
4	22			4	YYMMDDHH	LOT	L	224950928223C0013
5	22			5	YYJJJ	LOT	L	225952713C0013
6	22			6	YYJJJHH	LOT	L	22695271223C0013
7	22			7		LOT	L	2273C0013
8	22	8	QQ		MMYY	LOT	L	2282409953C0013
9	22	8	QQ	2	MMDDYY	LOT	L	2282420928953C0013
10	22	8	QQ	3	YYMMDD	LOT	L	2282439509283C0013
11	22	8	QQ	4	YYMMDDHH	LOT	L	228244950928223C0013
12	22	8	QQ	5	YYJJJ	LOT	L	228245952713C0013
13	22	8	QQ	6	YYJJJHH	LOT	L	22824695271223C0013
14	22	8	QQ	7		LOT	L	2282473C0013
15	22	8	QQ			LOT	L	228243
16	22	9	QQQQQ		MMYY	LOT	L	2290010009953C0013
17	22	9	QQQQQ	2	MMDDYY	LOT	L	2290010020928953C0013
18	22	9	QQQQQ	3	YYMMDD	LOT	L	2290010039509283C0013
19	22	9	QQQQQ	4	YYMMDDHH	LOT	L	229001004950928223C0013
20	22	9	QQQQQ	5	YYJJJ	LOT	L	229001005952713C0013
21	22	9	QQQQQ	6	YYJJJHH	LOT	L	22900100695271223C0013
22	22	9	QQQQQ	7		LOT	L	2290010073C0013
23	22	9	QQQQQ			LOT	L	229001003

As an example, row 8 in Figure 7.8 - 3, using the required AI (01) and AI (22), would create the full string ]C1 01 10312345678903 22 82409953C0013.

## 7.9. Processing of Data from a GS1 Symbology using GS1 Application Identifiers

Figure 7.9 - 1



This system logic holds true for any GS1 Symbology using GS1 Application Identifiers. The Symbology Identifiers listed in Figure 7.9-1 are:

1. Jc1 = GS1-128
2. Je0 = GS1 DataBar and Composite Symbols
3. Jd2 = GS1 DataMatrix

### 7.9.1. General

Any GS1 Symbology using GS1 Application Identifiers may represent several Element Strings in concatenated form (see Section 5). For processing as shown in Figure 7.3 - 1, it is necessary to separate each Element String, which is performed by the processing routine illustrated in Figure 7.9 - 1.

### 7.9.2. Element Strings with Pre-Defined Lengths Using Application Identifiers

Representation of more than one Element String in a GS1 Symbology using GS1 Application Identifiers requires the use of a Separator Character between the different Element Strings to mark their end. This is normally the Function 1 Symbol Character (FNC1) or, in the case of some types of GS1 DataBar, is part of the symbology specification. For details, see Section 5.

However, in order to enable printing of shorter bar code symbols, some Element Strings have been pre-defined in length, so that their end may be determined, and the FNC1 is not needed. These Element Strings are shown in Figure 5.4.8.2.1.

### 7.9.3. The Function 1 Symbol Character (FNC1)

Only when used as a Separator Character is the Function 1 Symbol Character (FNC1) transmitted in the decoded data string as <GS> (ASCII character 29, seven-bit character set ISO 646). All Element Strings of variable length and those of fixed length not stated in Figure 5.4.8.2.1 - 1 must be followed by an FNC1 when followed by another Element String in a single bar code symbol. An FNC1 is not required at the end of the last Element String represented in a bar code symbol or for certain AI combinations defined by the symbology specification (e.g., some types of GS1 DataBar).

## 7.10. Check Digit Calculations

### 7.10.1. Standard Check Digit Calculations for GS1 Data Structures

This algorithm is identical for all fixed length numeric GS1 Data Structures that require a Check Digit.

Figure 7.10.1 - 1

Digit Positions																									
GTIN-8													N <sub>1</sub>	N <sub>2</sub>	N <sub>3</sub>	N <sub>4</sub>	N <sub>5</sub>	N <sub>6</sub>	N <sub>7</sub>	N <sub>8</sub>					
GTIN-12							N <sub>1</sub>	N <sub>2</sub>	N <sub>3</sub>	N <sub>4</sub>	N <sub>5</sub>	N <sub>6</sub>	N <sub>7</sub>	N <sub>8</sub>	N <sub>9</sub>	N <sub>10</sub>	N <sub>11</sub>	N <sub>12</sub>	N <sub>13</sub>	N <sub>14</sub>					
GTIN-13						N <sub>1</sub>	N <sub>2</sub>	N <sub>3</sub>	N <sub>4</sub>	N <sub>5</sub>	N <sub>6</sub>	N <sub>7</sub>	N <sub>8</sub>	N <sub>9</sub>	N <sub>10</sub>	N <sub>11</sub>	N <sub>12</sub>	N <sub>13</sub>	N <sub>14</sub>	N <sub>15</sub>	N <sub>16</sub>	N <sub>17</sub>	N <sub>18</sub>		
GTIN-14					N <sub>1</sub>	N <sub>2</sub>	N <sub>3</sub>	N <sub>4</sub>	N <sub>5</sub>	N <sub>6</sub>	N <sub>7</sub>	N <sub>8</sub>	N <sub>9</sub>	N <sub>10</sub>	N <sub>11</sub>	N <sub>12</sub>	N <sub>13</sub>	N <sub>14</sub>	N <sub>15</sub>	N <sub>16</sub>	N <sub>17</sub>	N <sub>18</sub>	N <sub>19</sub>	N <sub>20</sub>	
17 digits		N <sub>1</sub>	N <sub>2</sub>	N <sub>3</sub>	N <sub>4</sub>	N <sub>5</sub>	N <sub>6</sub>	N <sub>7</sub>	N <sub>8</sub>	N <sub>9</sub>	N <sub>10</sub>	N <sub>11</sub>	N <sub>12</sub>	N <sub>13</sub>	N <sub>14</sub>	N <sub>15</sub>	N <sub>16</sub>	N <sub>17</sub>							
18 digits	N <sub>1</sub>	N <sub>2</sub>	N <sub>3</sub>	N <sub>4</sub>	N <sub>5</sub>	N <sub>6</sub>	N <sub>7</sub>	N <sub>8</sub>	N <sub>9</sub>	N <sub>10</sub>	N <sub>11</sub>	N <sub>12</sub>	N <sub>13</sub>	N <sub>14</sub>	N <sub>15</sub>	N <sub>16</sub>	N <sub>17</sub>	N <sub>18</sub>							
Multiply value of each position by																									
x3	X1	x3	x1	x3	x1	x3	x1	x3	x1	x3	x1	x3	x1	x3	x1	x3	x1	x3							
Accumulated results = sum																									
Subtract sum from nearest equal or higher multiple of ten = Check Digit →																									

Figure 7.10.1 - 2

Example of a Check Digit Calculation for the 18-Digit Field																		
Positions	N <sub>1</sub>	N <sub>2</sub>	N <sub>3</sub>	N <sub>4</sub>	N <sub>5</sub>	N <sub>6</sub>	N <sub>7</sub>	N <sub>8</sub>	N <sub>9</sub>	N <sub>10</sub>	N <sub>11</sub>	N <sub>12</sub>	N <sub>13</sub>	N <sub>14</sub>	N <sub>15</sub>	N <sub>16</sub>	N <sub>17</sub>	N <sub>18</sub>
Number without Check Digit	3	7	6	1	0	4	2	5	0	0	2	1	2	3	4	5	6	
Step 1: multiply by	x	x	x	x	x	x	x	x	x	x	x	x	x	x	x	x	x	
	3	1	3	1	3	1	3	1	3	1	3	1	3	1	3	1	3	
Step 2: add up results to sum	=	=	=	=	=	=	=	=	=	=	=	=	=	=	=	=	=	
	9	7	18	1	0	4	6	5	0	0	6	1	6	3	12	5	18	= 101
Step 3: Subtract sum from nearest equal or higher multiple of ten (110) = Check Digit (9)																		
Number with Check Digit	3	7	6	1	0	4	2	5	0	0	2	1	2	3	4	5	6	9

### 7.10.2. Check Digit Calculation for Price/Weight Fields

To increase the security of reading a price or weight from a bar code symbol, the Check Digit for these fields is not only calculated according to the methods described in the previous section, but also according to the procedure described in this section.

The basic principle of the Check Digit calculation is that each digit position in a price/weight field is assigned a weighting factor. Weighting factors are 2-, 3, 5+, and 5-. Each weighting factor affects the

particular calculation for the position concerned. The result of such a calculation is called a weighted product.

The figures that follow show the weighted products of the various weighting factors.

**Figure 7.10.2 - 1**

<b>Weighting Factor 2</b>										
Calculation rule: The digit is multiplied by 2. If the result has two digits, the tens digit is subtracted from the units digit. The units digit resulting is the weighted product.										
Digit	0	1	2	3	4	5	6	7	8	9
Weighted product	0	2	4	6	8	9	1	3	5	7

**Figure 7.10.2 - 2**

<b>Weighting Factor 3</b>										
Calculation rule: The digit is multiplied by 3. The unit's digit of the result is the weighted product.										
Digit	0	1	2	3	4	5	6	7	8	9
Weighted product	0	3	6	9	2	5	8	1	4	7

**Figure 7.10.2 - 3**

<b>Weighting Factor 5+</b>										
Calculation rule: The digit is multiplied by 5. The units digit and the tens digit of the result are added together. The result of this sum is the weighted product.										
Digit	0	1	2	3	4	5	6	7	8	9
Weighted product	0	5	1	6	2	7	3	8	4	9

**Figure 7.10.2 - 4**

<b>Weighting Factor 5-</b>										
Calculation rule: The digit is multiplied by 5. The tens digit of the result is subtracted from the result. The units digit of the result of this subtraction is the weighted product.										
Digit	0	1	2	3	4	5	6	7	8	9
Weighted product	0	5	9	4	8	3	7	2	6	1

### 7.10.3. Check Digit Calculation for the Four-Digit Price Field

Figure 7.10.3 - 1

Assigned Weighting Factors				
Digit position	1	2	3	4
Weighting factor	2-	2-	3	5-

- **Calculation step 1:** Determine the weighted product for each number in Positions One to Four according to the assigned weighting factors.
- **Calculation step 2:** Add the products of step 1.
- **Calculation step 3:** Multiply the result of step 2 by the factor 3. The unit's digit of the result is the Check Digit.

Figure 7.10.3 – 2

Example of a Check Digit Calculation					
Position of price field	1	2	3	4	
Assigned weighting factor	2-	2-	3	5-	
Amount	2	8	7	5	
Step 1: weighted product according to figure	4	5	1	3	
Step 2: sum	+	+	+	+	= 13
Step 3: multiply by 3					= 39

Unit position is the Check Digit



### 7.10.4. Check Digit Calculation for the Five-Digit Price Field

Figure 7.10.4 – 1

Assigned Weighting Factors					
Digit positions	1	2	3	4	5
Weighting factor	5+	2-	5-	5+	2-

- **Calculation step 1:** Determine the weighted product for each number in Positions one to five according to the assigned weighting factors.
- **Calculation step 2:** Add the products of step 1.
- **Calculation step 3:** Subtract the result from the nearest equal or higher multiple of 10.
- **Calculation step 4:** Take the result and search for the same number in the weighted product row of Figure 7.10.2 – 4. The Check Digit is the number in the digit row of the same column.

**Figure 7.10.4 – 2**

Example of a Check Digit Calculation						
Price field positions	1	2	3	4	5	
Assigned weighting factor	5+	2-	5-	5+	2-	
Amount	1	4	6	8	5	
Step 1: weighted product according to figure	5	8	7	4	9	
Step 2: sum	+	+	+	+	+	= 33
Step 3: result of subtraction (40 - 33)						= 7
Step 4: weighted product 7 in the figure weighting factor 5- shows number 6 to be the Check Digit.						

### 7.11. GTIN-12 and RCN-12 in a UPC-E Bar Code Symbol

Some of the GTIN-12 and RCN-12 number ranges beginning with the U.P.C. Prefix 0 may be represented in a small symbol called the UPC-E Bar Code Symbol (see section 2.1.2.1.2 and section 2.1.7.3).

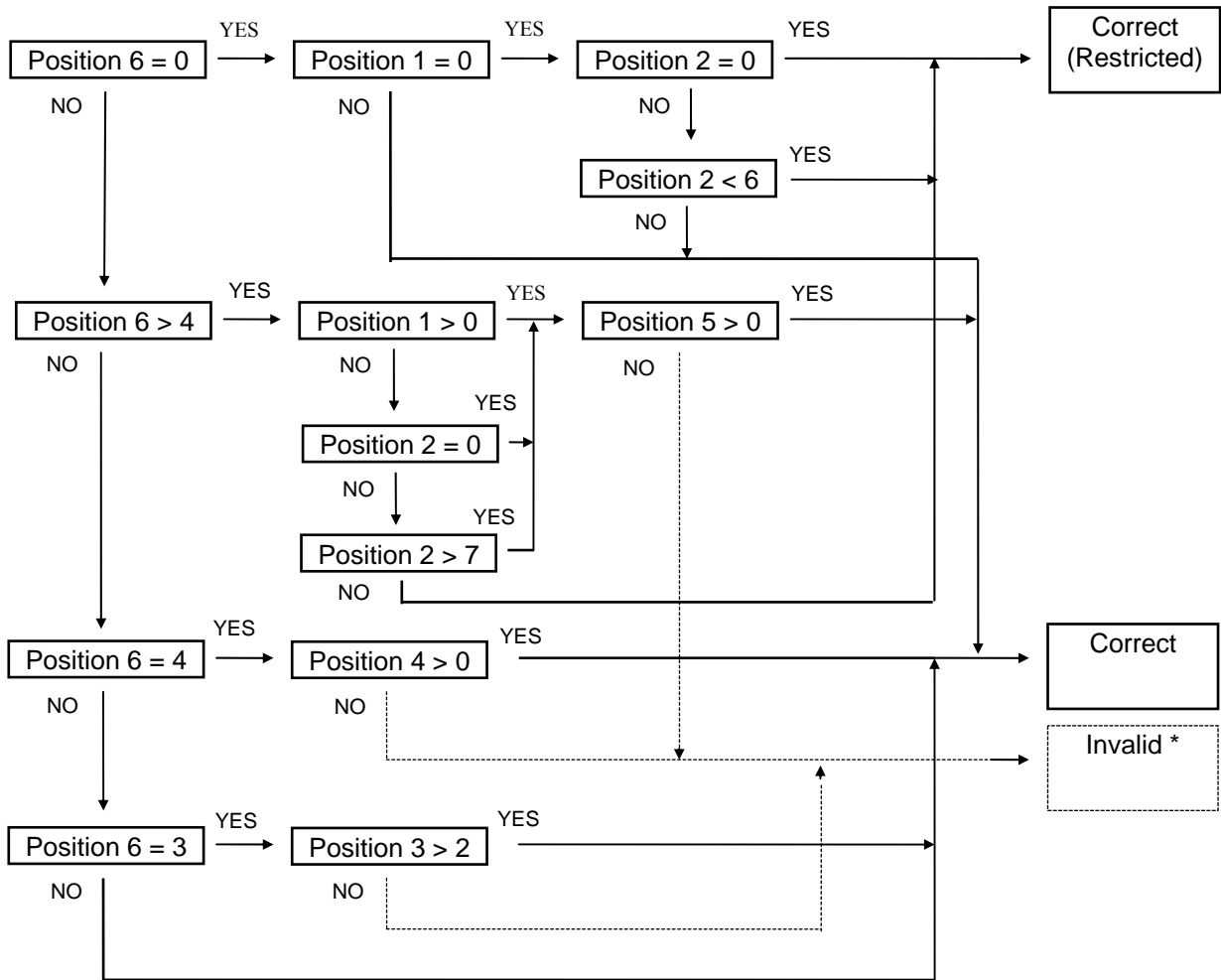
The GTIN-12 or RCN-12 is condensed into a bar code symbol consisting of six symbol character positions. For application processing, the GTIN-12 or RCN-12 must be transformed into its full length by the bar code reader software or by the application software. There is no six-digit UPC-E Bar Code Symbol.

It is possible to create false UPC-E Bar Code Symbols if the encodation rules are not properly observed. Whether the digits represented in a UPC-E Bar Code Symbol can be expanded correctly to a GTIN-12 may be verified by the following tests.

**Test 1:**

Verify the digits encoded in Positions 1 to 6 of the UPC-E Bar Code Symbol according to the diagram in Figure 7.11 - 1.

Figure 7.11 –1



**Note:** These UPC-E Bar Code Symbols were valid in previous specifications. Provision for accepting them must be made during decoding only.

**Test 2:**

Expand the digits encoded in the UPC-E Bar Code Symbol to the first 11 digits of the full length GTIN-12, calculate the Check Digit, and compare it with the Check Digit decoded from the UPC-E Bar Code Symbol. If they do not match, it signifies an invalid symbol.

## 7.12. The International Standard ISO/IEC 646

Figure 7.12 - 1 Unique Graphic Character Allocations

Graphic Symbol	Name	Coded Representation	Graphic Symbol	Name	Coded Representation
!	Exclamation mark	2/1	M	Capital letter M	4/13
"	Quotation mark	2/2	N	Capital letter N	4/14
%	Percent sign	2/5	O	Capital letter O	4/15
&	Ampersand	2/6	P	Capital letter P	5/0
'	Apostrophe	2/7	Q	Capital letter Q	5/1
(	Left parenthesis	2/8	R	Capital letter R	5/2
)	Right parenthesis	2/9	S	Capital letter S	5/3
*	Asterisk	2/10	T	Capital letter T	5/4
+	Plus sign	2/11	U	Capital letter U	5/5
,	Comma	2/12	V	Capital letter V	5/6
-	Hyphen/Minus	2/13	W	Capital letter W	5/7
.	Full stop	2/14	X	Capital letter X	5/8
/	Solidus	2/15	Y	Capital letter Y	5/9
0	Digit zero	3/0	Z	Capital letter Z	5/10
1	Digit one	3/1	_	Low line	5/15
2	Digit two	3/2	a	Small letter a	6/1
3	Digit three	3/3	b	Small letter b	6/2
4	Digit four	3/4	c	Small letter c	6/3
5	Digit five	3/5	d	Small letter d	6/4
6	Digit six	3/6	e	Small letter e	6/5
7	Digit seven	3/7	f	Small letter f	6/6
8	Digit eight	3/8	g	Small letter g	6/7
9	Digit nine	3/9	h	Small letter h	6/8
:	Colon	3/10	i	Small letter i	6/9
;	Semicolon	3/11	j	Small letter j	6/10
<	Less-than sign	3/12	k	Small letter k	6/11
=	Equals sign	3/13	l	Small letter l	6/12
>	Greater-than sign	3/14	m	Small letter m	6/13
?	Question mark	3/15	n	Small letter n	6/14
A	Capital letter A	4/1	o	Small letter o	6/15
B	Capital letter B	4/2	p	Small letter p	7/0
C	Capital letter C	4/3	q	Small letter q	7/1
D	Capital letter D	4/4	r	Small letter r	7/2

Graphic Symbol	Name	Coded Representation	Graphic Symbol	Name	Coded Representation
E	Capital letter E	4/5	s	Small letter s	7/3
F	Capital letter F	4/6	t	Small letter t	7/4
G	Capital letter G	4/7	u	Small letter u	7/5
H	Capital letter H	4/8	v	Small letter v	7/6
I	Capital letter I	4/9	w	Small letter w	7/7
J	Capital letter J	4/10	x	Small letter x	7/8
K	Capital letter K	4/11	y	Small letter y	7/9
L	Capital letter L	4/12	z	Small letter z	7/10

### 7.13. Determination of Century in Dates

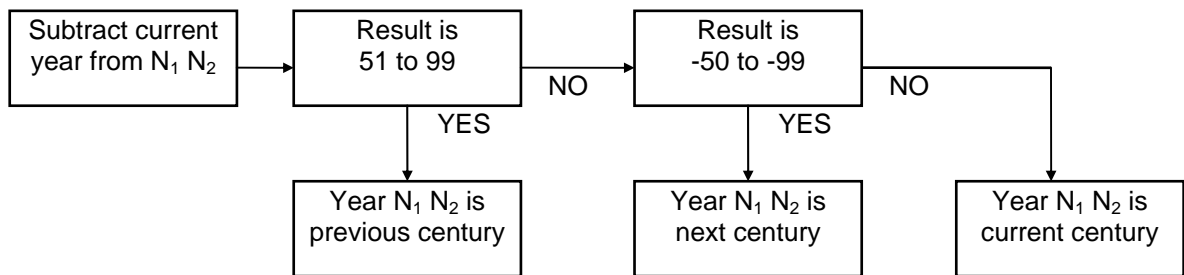
Element Strings are available for the following types of dates:

- Production date: AI (11)
- Due date: AI (12)
- Packaging date: AI (13)
- Best before date (quality): AI (15)
- Expiration date (safety): AI (17)
- Date and time of production: AI (8008)

It is left to the discretion of the user to interpret a particular date type in the sense of his business practices. Such interpretation may change according to the product range for which a date is being applied.

Since the year data field consists of two positions, the century is established by following the procedure in Figure 7.14 - 1.

Figure 7.14 - 1



**Note:** The Element String can only specify a date in the range from 49 years in the past to 50 years in the future of the current year.



## Section 8. GS1 Standards Glossary of Terms

- GS1 Glossary Terms and Definitions
- GS1 Abbreviations
- Legacy (Retired) Terms

Whilst every effort has been made to ensure that the guidelines to use the GS1 standards contained in the document are correct, GS1 and any other party involved in the creation of the document HEREBY STATE that the document is provided without warranty, either expressed or implied, of accuracy or fitness for purpose, AND HEREBY DISCLAIM any liability, direct or indirect, for damages or loss relating to the use of the document. The document may be modified, subject to developments in technology, changes to the standards, or new legal requirements.

Several products and company names mentioned herein may be trademarks and/or registered trademarks of their respective companies.

## 8.1. GS1 Glossary Terms and Definitions

Term	Definition
2-Dimensional Symbology	Optically readable symbols that must be examined both vertically and horizontally to read the entire message. Two-dimensional symbols may be one of two types: matrix symbols and multi-row symbols. Two dimensional symbols have error detection and may include error correction features (using ISO/IEC 16022 for reference).
Add-On Symbol	A bar code symbol used to encode information supplementary to that in the main bar code symbol.
AIDC	See Automatic Identification Data Capture
AIDC Data Validation	Verification of scanned/read data from bar codes or RFID tags to determine whether it meets the application rules for system logic and consistency and/or a particular user's requirements, prior to processing in applications.
alphanumeric (an)	Describes a character set that contains alphabetic characters (letters), numeric digits (numbers), and other characters, such as punctuation marks.
aperture	A physical opening that is part of the optical path in a device such as a scanner, photometer, or camera. Most apertures are circular, but they may be rectangular or elliptical.
Asset Type	A component of the Global Returnable Asset Identifier (GRAI) assigned by the owner of the GS1 Company Prefix to create a unique GRAI.
attribute	A piece of information reflecting a characteristic related to an identification number (e.g., Global Trade Item Number (GTIN), SSCC).
autodiscrimination	The capability of a reader to automatically recognise and decode multiple bar code symbologies.
Automatic Identification and Data Capture	A technology used to automatically capture data. AIDC technologies include bar code symbols, smart cards, biometrics and RFID.
auxiliary guard patterns	Components of the EAN/UPC Symbology. The centre guard bar pattern, the left guard bar pattern, and the right bar patterns that are represented in some of the symbols are specific types of auxiliary guard pattern.
Bar Code Verification	The scientific verification of a bar code symbol based on ISO standards and calibrated bar code verifiers, with the appropriate light source angle and aperture size for the X dimension of that bar code symbol.
bar gain/loss	The increase/decrease in bar width due to effects of the reproduction and printing processes.
Batch / Lot	The batch or lot number associates an item with information the manufacturer considers relevant for traceability of the trade item. The data may refer to the trade item itself or to items contained.
Bearer Bars	Bar abutting the tops and bottoms of the bars in a bar code symbol, or a frame surrounding the entire symbol, intended to equalize the pressure exerted by the printing plate over the entire surface of the symbol and/or to prevent a short scan by the bar code reader
brand owner	The party that is responsible for allocating GS1 System numbering and bar code symbols on a given trade item. The administrator of a GS1 Company Prefix.
carrier	The party that provides freight transportation services or a physical or electronic mechanism that carries data.
Check Digit	A digit calculated from the other digits of an Element String, used to check that the data has been correctly composed. (See GS1 Check Digit Calculation.)

Term	Definition
Company Number	A component of the GS1 Company Prefix. GS1 Member Organisations assign GS1 Company Prefixes to entities that administer the allocation of GS1 System identification numbers. These entities may be, for example, commercial companies, not for profit organisations, governmental agencies, and business units within organisations. Criteria to qualify for the assignment of a GS1 Company Prefix are set by the GS1 Member Organisations.
Composite Component	This term is used to refer to either the linear or 2D symbol component within a composite symbol.
Composite Symbology	A GS1 System composite symbol consists of a linear component (encoding the item's primary identification) associated with an adjacent 2D Composite Component (encoding supplementary data, such as a batch number or expiration date). The composite symbol always includes a linear component so that the primary identification is readable by all scanning technologies, and so that 2D imager scanners can use the linear component as a finder pattern for the adjacent 2D Composite Component. The one exception is that there is no linkage flag for EAN/UPC symbology. The composite symbol always includes one of three multi-row 2D Composite Component versions (e.g., CC-A, CC-B, CC-C) for compatibility with linear- and area-CCD scanners and with linear and rastering laser scanners.
concatenation	The representation of several Element Strings in one bar code symbol.
coupon	A voucher that can be redeemed at the Point-of-Sale for a cash value or free item.
Coupon Extended Bar Code	A supplemental bar code, used only in North America, that can be printed on a coupon to provide additional information, such as Offer Codes, expiration dates, and household identification numbers.
Coupon-12	A twelve-digit Restricted Circulation Number for coupons structured according to the rules defined in the target market.
Coupon-13	The 13-digit GS1 System Restricted Circulation Number defined according to rules in a target market used for coupons.
customer	The party that receives, buys, or consumes an item or service.
data carrier	A means to represent data in a machine readable form; used to enable automatic reading of the Element Strings.
data character	A letter, digit, or other symbol represented in the data field(s) of an Element String.
Data Matrix	A standalone, two-dimensional matrix symbology that is made up of square modules arranged within a perimeter finder pattern. Data Matrix ISO version ECC 200 is the only version that supports GS1 System identification numbers, including Function 1 Symbol Character. Data Matrix Symbols are read by two-dimensional imaging scanners or vision systems.
data titles	Data titles are the abbreviated descriptions of data fields which are used to support manual interpretation of bar codes.
Default Front	The side of a consumer trade item that is used as the starting point to capture dimensional attributes for the purpose of data alignment.
Direct Part Marking	Direct part marking refers to the process of marking a symbol on an item using an intrusive or non-intrusive method.
direct print	A process in which the printing apparatus prints the symbol by making physical contact with a substrate (e.g., flexography, ink jet, dot peening).
Document Type	A component of a Global Document Type Identifier (GDTI) assigned by the owner of the GS1 Company Prefix to create a unique GDTI.

Term	Definition
Dynamic Assortment	A standard trade item grouping that comprises a fixed count of a changing assortment of two or more different retail consumer trade items, each identified with a unique GTIN. The retailer has accepted that the supplier may change the assortment without any prior notice.
EAN/UPC Composite Symbology Family	A family of bar code symbols comprising the UPC-A Composite Symbology, UPC-E Composite Symbology, EAN-8 Composite Symbology, and EAN-13 Composite Symbology.
EAN/UPC Symbology	A family of bar code symbols including EAN-8, EAN-13, UPC-A, and UPC-E Bar Code Symbols. Although UPC-E Bar Code Symbols do not have a separate symbology identifier, they act like a separate symbology through the scanning application software. See also EAN-8 Bar Code Symbol, EAN-13 Bar Code Symbol, UPC-A Bar Code Symbol, and UPC-E Bar Code Symbol.
EAN-13 Bar Code Symbol	A bar code symbol of the EAN/UPC Symbology that encodes GTIN-13, Coupon-13, RCN-13, and VMN-13.
EAN-13 Composite Symbology	The Composite Symbology that utilises an EAN-13 Bar Code Symbol as the linear component.
EAN-8 Bar Code Symbol	A bar code symbol of the EAN/UPC Symbology that encodes GTIN-8 or RCN-8.
EAN-8 Composite Symbology	The Composite Symbology that utilises an EAN-8 Bar Code Symbol as the linear component.
EANCOM	The GS1 standard for Electronic Data Interchange (EDI) is a detailed implementation guideline of the UN/EDIFACT standard messages using the GS1 Identification Keys.
Electronic Commerce	The conduct of business communications and management through electronic methods, such as Electronic Data Interchange (EDI) and automated data collection systems.
Electronic Message	A composition of Element Strings from scanned data and transaction information assembled for data validation and unambiguous processing in a user application.
Electronic Product Code	An identification scheme for universally identifying physical objects (e.g. trade items, assets, and locations) via RFID tags and other means. The standardised EPC data consists of an EPC (or EPC Identifier) that uniquely identifies an individual object, as well as an optional Filter Value when judged to be necessary to enable effective and efficient reading of the EPC tags.
Element String	The combination of a GS1 Application Identifier and GS1 Application Identifier Data Field.
EPC Manager Number	The number allocated to a company or a company entity.
EPC Middleware	EPC Middleware is the component of the EPCglobal Network that manages real-time read events and information, provides alerts, and manages the basic read information for communication to EPC Information Services and a company's other existing information systems. EPCglobal is developing a software interface standard for services enabling data exchange between an EPC reader or network of readers and information systems.
EPC Object Naming Service (ONS)	Business information systems need a way of matching the Electronic Product Code to information about the associated item. The ONS is an automated networking service that provides this service by pointing computers to sites on the World Wide Web.
EPC tag	RFID tag that complies with the EPCglobal standard and contains an Electronic Product Code.

Term	Definition
EPCglobal Inc	A not-for-profit organisation entrusted by industry to establish and support the Electronic Product Code and the global adoption of the EPCglobal Network as the global standards for immediate, automatic and accurate identification of any item in the supply chain of any company, in any industry, in any country in the world.
EPCglobal Network	A set of technologies that enable immediate, automatic identification and sharing of information on items in the supply chain.
EPCglobal Tag Data Standard	A specification or set of guidelines that, after extensive consensus-building, has received the endorsement of EPCglobal members and the EPCglobal Board of Governors.
even parity	A characteristic of the encodation of a symbol character whereby the symbol character contains an even number of dark modules.
Extension digit	The first digit within the SSCC (Serial Shipping Container Code) which is allocated by the user and is designed to increase the capacity of the SSCC.
fixed length	Term used to describe a data field in an Element String with an established number of characters.
Fixed Measure Trade Item	An item always produced in the same pre-defined version (e.g., type, size, weight, contents, design) that may be sold at any point in the supply chain.
Full String	The data transmitted by the bar code reader from reading a data carrier, including symbology identifier and Element String(s).
Function 1 Symbol Character (FNC1)	A symbology character used in some GS1 data carriers for specific purposes.
GDTI	See Global Document Type Identifier
General Distribution Scanning	Scanning environments that include bar coded trade items packaged for transport, logistic units, assets, and location tags.
GIAI	See Global Individual Asset Identifier
GLN	See Global Location Number
GLN Extension	The GLN extension component is used to identify internal physical locations within a location which is identified with a GLN (stores, factories, buildings, etc.).
Global Document Type Identifier (GDTI)	The GS1 Identification Key used to identify a document type with an optional serial number. The key is comprised of a GS1 Company Prefix, Document Type, and Check Digit.
Global Individual Asset Identifier (GIAI)	The GS1 Identification Key used to identify an Individual Asset. The key is comprised of a GS1 Company Prefix and Individual Asset Reference.
Global Location Number (GLN)	The GS1 Identification Key used to identify physical locations or legal entities. The key is comprised of a GS1 Company Prefix, Location Reference, and Check Digit.
Global Returnable Asset Identifier (GRAI)	The GS1 Identification Key used to identify Returnable Assets. The key is comprised of a GS1 Company Prefix, Asset Type, Check Digit, and optional serial number.
Global Service Relation Number (GSRN)	The GS1 Identification Key used to identify the relationship between a service provider and service recipient. The key is comprised of a GS1 Company Prefix, Service Reference, and Check Digit.
Global Standards Management Process	GS1 created the Global Standards Management Process (GSMP) to support standards development activity for the GS1 System. The GSMP uses a global consensus process to develop supply chain standards that are based on business needs and user-input

Term	Definition
Global Trade Item Number (GTIN)	The GS1 Identification Key used to identify trade items. The key is comprised of a GS1 or U.P.C. Company Prefix followed by an Item Reference Number and a Check Digit.
GRAI	See Global Returnable Asset Identifier
GS1 Application Identifier	The field of two or more characters at the beginning of an Element String that uniquely defines its format and meaning.
GS1 Application Identifier data field	The data used in a business application defined by one application identifier.
GS1 Check Digit Calculation	A GS1 System algorithm for the calculation of a Check Digit to verify accuracy of data. (e.g.: Mod 10, Price check digit).
GS1 Common Currency Coupon Code	An identification number for coupons issued in a common currency area (e.g., the euro currency) that uses the Coupon Code-13 Data Structure.
GS1 Company Prefix	Part of the GS1 System identification number consisting of a GS1 Prefix and a Company Number, both of which are allocated by GS1 Member Organisations.
GS1 DataBar Stacked Composite Symbology	The GS1 DataBar Composite Symbology that utilises a GS1 DataBar Stacked Bar Code Symbol as the linear component.
GS1 DataBar Composite Symbology Family	A family of symbols comprised of the GS1 DataBar Composite Symbology, GS1 DataBar Stacked Composite Symbology, GS1 DataBar Limited Composite Symbology, and GS1 DataBar Expanded Composite Symbology.
GS1 DataBar Expanded Bar Code Symbol (formerly RSS Expanded)	A bar code symbol that encodes a GTIN plus supplementary AI Element Strings, such as weight and “best before” date, in a linear symbol that can be scanned omnidirectionally by suitably programmed Point-of-Sale scanners.
GS1 DataBar Expanded Composite Symbology	The GS1 DataBar Composite Symbology that utilises an GS1 DataBar Expanded Bar Code Symbol as the linear component.
GS1 DataBar Expanded Stacked Bar Code Symbol (formerly RSS Expanded Stacked)	A bar code symbol that is a variation of the GS1 DataBar Expanded Bar Code Symbol that is stacked in multiple rows and is used when the normal symbol would be too wide for the application.
GS1 DataBar Expanded Stacked Composite Bar Code Symbol	The GS1 DataBar Composite Symbology that utilises an GS1 DataBar Expanded Stacked Bar Code Symbol as the linear component.
GS1 DataBar Limited Bar Code Symbol (formerly RSS Limited)	A bar code symbol that encodes a GTIN with a leading digit zero or Indicator digit one in a linear symbol; for use on small items that will not be scanned at the Point-of-Sale.
GS1 DataBar Limited Composite Symbology	The GS1 DataBar Composite Symbology that utilises an GS1 DataBar Limited Bar Code Symbol as the linear component.
GS1 DataBar Omnidirectional (formerly RSS-14)	The members of the GS1 DataBar Symbology family designed to be read in segments by omnidirectional scanners at retail POS: GS1 DataBar Omnidirectional; GS1 DataBar Stacked Omnidirectional; GS1 DataBar Expanded; GS1 DataBar Expanded Stacked.
GS1 DataBar (formerly RSS)	A family of bar code symbols, including GS1 DataBar Truncated, GS1 DataBar Limited, GS1 DataBar Expanded, and GS1 DataBar Stacked. Any member of the GS1 DataBar family can be printed as a stand-alone linear symbol or as a composite symbol with an accompanying 2D Composite Component printed directly above the GS1 DataBar linear component.
GS1 DataBar Retail POS Family	The members of the GS1 DataBar Symbology family designed to be read in segments by omnidirectional scanners at retail POS: GS1 DataBar Omnidirectional; GS1 DataBar Stacked Omnidirectional; GS1 DataBar Expanded; GS1 DataBar Expanded Stacked.

Term	Definition
GS1 DataBar Stacked Omnidirectional Symbol (formerly RSS-14 Stacked Omnidirectional)	A bar code symbol that is a variation of the GS1 DataBar Symbology that is stacked in two rows and is used when the GS1 Omnidirectional Symbol would be too wide for the application. It is designed to be read by omnidirectional checkout scanners.
GS1 DataBar Stacked Symbol	A bar code symbol that is a variation of the GS1 DataBar Truncated Symbol that is stacked in two rows and is used when the GS1 DataBar Truncated Symbol would be too wide for the application.
GS1 DataBar Truncated Symbol	A bar code symbol that is a truncated version of the GS1 DataBar Omnidirectional Symbol. It is used when the GS1 DataBar Omnidirectional Symbol would be too tall for small item marking applications. It is not intended for omnidirectional checkout scanning.
GS1 DataMatrix	GS1 implementation specification for use of Data Matrix
GS1 EANCOM	The GS1 standard for Electronic Data Interchange (EDI) is a detailed implementation guideline of the UN/EDIFACT standard messages using the GS1 Identification Keys.
GS1 General Specifications	Defines the GS1 System data and application standards related to the marking and automatic identification of trade items, locations, logistic units, assets, and more using bar code, RFID, and GS1 Identification Keys.
GS1 Global Data Dictionary	A repository tool used to record GS1 member standards agreements on business terms and definitions used by all business units.
GS1 Global Office	Based in Brussels, Belgium, and Princeton, USA, is an organisation of GS1 Member Organisations that manages the GS1 System.
GS1 Global Product Classification	A component of GS1 GDSN. It provides the required global framework for trade item categorisation supporting global data synchronisation.
GS1 Global Registry	A component of GS1 GDSN. It acts as a pointer (directory for the registration) to GDSN certified data pools where catalogue item and party master data is housed. It also fulfils the role of matching subscriptions to registrations to facilitate the synchronisation process.
GS1 Global Standards Management Process	A component of GS1 Services. It is offered as an integral part of GS1's standards development and maintenance process. It allows for user members' active involvement.
GS1 Identification Key	A numeric or alphanumeric field managed by GS1 to ensure the global, unambiguous uniqueness of the identifier in the open demand or supply chain.
GS1 Identification Keys	A globally managed system of numbering used by all GS1 Business Units to identify trade items, logistic units, locations, legal entities, assets, service relationships, and more. The Keys are built by combining GS1 member company identifiers (GS1 Company Prefix) with standards based rules for allocating reference numbers.
GS1 Member Organisation	A member of GS1 that is responsible for administering the GS1 System in its country (or assigned area). This task includes, but is not restricted to, ensuring user companies make correct use of the GS1 System, have access to education, training, promotion and implementation support and have access to play an active role in GSMP.
GS1 Prefix	A number with two or more digits, administered by the GS1 Global Office that is allocated to GS1 Member Organisations or for Restricted Circulation Numbers.
GS1 Symbologies using GS1 Application Identifiers	All GS1 endorsed bar code symbologies that can encode more than a GTIN namely GS1-128, GS1 DataMatrix, GS1 DataBar and Composite).
GS1 System	The specifications, standards, and guidelines administered by GS1.

Term	Definition
GS1 XML	The GS1 standard for Extensible Markup Language schemas providing users with a global business messaging language of e-business to conduct efficient Internet-based electronic commerce.
GS1-128 Bar Code Symbology	A subset of the Code 128 that is utilised exclusively for GS1 System data structures.
GS1-128 Composite Symbology	A Composite Symbology that utilises a GS1-128 Bar Code Symbol as the linear component.
GS1-8 Prefix	A one-, two-, or three-digit index number, administered by GS1, denoting the area of distribution of trade items identified by a GTIN-8 or a number used in internal application (see RCN-8).
GSMP	See Global Standards Management Process
GSRN	See Global Service Relationship Number.
GTIN	See Global Trade Item Number
GTIN Application Format	A format for a GTIN-8, GTIN-12, or GTIN-13 used when a GTIN application requires a fixed field length, for example, carrying a GTIN in GS1-128 Symbology with a (01) Application Identifier.
GTIN-12	The 12-digit GS1 Identification Key composed of a U.P.C. Company Prefix, Item Reference, and Check Digit used to identify trade items.
GTIN-13	The 13-digit GS1 Identification Key composed of a GS1 Company Prefix, Item Reference, and Check Digit used to identify trade items.
GTIN-14	The 14-digit GS1 Identification Key composed of an Indicator digit (1-9), GS1 Company Prefix, Item Reference, and Check Digit used to identify trade items.
GTIN-8	The 8-digit GS1 Identification Key composed of a GS1-8 Prefix, Item Reference, and Check Digit used to identify trade items.
Guard Bar Pattern	An auxiliary pattern of bars/spaces corresponding to start or stop patterns in bar code symbologies, and serving to separate the two halves of EAN-8, EAN-13, and UPC-A Symbols.
Hanging Item	Any consumer trade item that is normally presented in the store in a hanging position.
Header	Identifies the length, type, structure, version and generation of Electronic Product Code.
House Way Bill Number	A freight forwarder's document used mainly as a control for the goods within the freight forwarder's own service system.
Human Readable Interpretation	Characters that can be read by persons, such as letters and numbers, as opposed to symbol characters within bar code symbols, which are read by machines.
Identification number	A numeric or alphanumeric field intended to enable the recognition of one entity versus another.
Indicator	A digit from 1 to 9 in the leftmost position of the GTIN-14.
Individual Asset	An entity that is part of the inventory of assets for a given company. (See also Returnable Asset.)
Individual Asset Reference	A component of the Global Individual Asset Identifier (GIAI) assigned by the owner of the GS1 Company Prefix to create a unique GIAI.
Inner Trade Item Grouping	Intermediate package of multiples of the same trade item or a standard assortment of trade items. An inner trade item grouping may or may not be sold at POS. (In some regions may also be referred to as Inner Pack).

Term	Definition
Interleaved 2 of 5 Symbology	Bar code symbology used for the ITF-14 Bar Code Symbol.
Inverse Exponent	The Application Identifier digit that denotes the implied decimal point position in an Element String.
Item Reference	A component of the Global Trade Item Number (GTIN) assigned by the owner of the GS1 Company Prefix or U.P.C. Company Prefix to create a unique GTIN.
ITF Symbology	See Interleaved 2 of 5 Symbology.
ITF-14 Bar Code Symbol	ITF-14 (A subset of Interleaved 2-of-5) Bar Code Symbols carry GTINs only on trade items that are not expected to pass through the Point-of-Sale.
Linear Bar Code	Bar Code symbology using bars and spaces in one dimension.
Local Assigned Code	A particular use of the UPC-E Bar Code Symbol for restricted distribution.
Location Reference	A component of a Global Location Number (GLN) assigned by the owner of the GS1 company prefix to create a unique GLN.
Logistic measures	Measures indicating the outside dimensions, total weight, or volume inclusive of packing material of a logistic unit. Also known as gross-measures.
Logistic unit	An item of any composition established for transport and/or storage that needs to be managed through the supply chain. It is identified with SSCC.
Magnification	Different sizes of bar code symbols based on a nominal size and a fixed aspect ratio; stated as a percent or decimal equivalent of a nominal size.
Measure check-digit	A digit calculated from the measure field of an Element String encoded using the EAN/UPC Symbology. Used to check that the data has been correctly composed.
Measure verifier-digit	The result of a special calculation of the digits in the item measure field and ensures the correct reading of the item measurement.
Module	The narrowest nominal width unit of measure in a bar code symbol. In certain symbologies, element widths may be specified as multiples of one module. Equivalent to X-dimension.
Modulo	An arithmetic scheme in which the result is the remainder after division.
Modulo 10	Modulo 10 creates a Check Digit according to the Modulo 10 algorithm specified in the GS1 General Specifications.
Modulo 103 GS1-128 Symbol Check Character	A number that results from a modulo calculation that is encoded in the GS1-128 Bar Code Symbol as a self-checking symbol character. It is created automatically by software as a symbol overhead character and is not expressed in the Human Readable Interpretation.
Natural Base	The side of a non-consumer trade item package that is used as a reference point for capturing dimensional attributes for the purpose of data alignment.
Non-GTIN Packs	A packaging level for trade items where there is no trading partner requirement for GTIN identification. If a GTIN is required, then this item becomes a retail consumer trade item or standard trade item grouping.
Object Class	Similar to a stock keeping unit SKU or trade item level.
Odd parity	A characteristic of the encodation of a symbol character whereby the symbol character contains an odd number of dark modules.
Payment slip	The end customer's notification of a demand for payment for a billable service (e.g., utility bill) comprising an amount payable and payment conditions.
Platform	Pallet or slip sheet or other device used to store or move a unit load, whether a logistics unit or a GTIN.
Point-of-Sale (POS)	Refers to the retail type checkout where bar code symbols are normally scanned.

Term	Definition
Price check-digit	A digit calculated from the price field of an Element String encoded using the EAN/UPC Symbology. Used to check that the data has been correctly composed.
Primary bar code	The bar code containing the identification number of the item (e.g. GTIN, SSCC). Used to determine the placement of any additional bar code information.
Print Gain Gauge	A printed test pattern used to determine the print gain mean and the range of print gain (press variance) as it relates to bar widths. It may also be used throughout the print run to indicate whether the anticipated range of print gain is experienced.
Quiet Zone	A clear space which precedes the Start Character of a bar code symbol and follows the Stop Character. Formerly referred to as "Clear Area" or "Light Margin."
Quiet Zone Indicator	A greater than (>) or less than (<) character, printed in the human readable field of the bar code symbol, with the tip aligned with the outer edge of the Quiet Zone.
Radio frequency	Any frequency within the electromagnetic spectrum associated with radio wave propagation. When a radio frequency current is supplied to an antenna, an electromagnetic field is created that then is able to propagate through space. Many wireless technologies are based on radio frequency field propagation.
Radio Frequency Identification	A data carrier technology that transmits information via signals in the radio frequency portion of the electromagnetic spectrum. A Radio Frequency Identification system consists of an antenna and a transceiver, which read the radio frequency and transfer the information to a processing device, and a transponder, or tag, which is an integrated circuit containing the radio frequency circuitry and information to be transmitted.
RCN-8	An 8-digit Restricted Circulation Number (see Restricted Circulation Number) beginning with GS1-8 Prefix 0 or 2.
RCN-12	A 12-digit Restricted Circulation Number (see Restricted Circulation Number).
RCN-13	A 13-digit Restricted Circulation Number (see Restricted Circulation Number).
Refund Receipt	A voucher produced by equipment handling empty containers (bottles and crates).
Restricted Circulation Numbers	Signifies a GS1 identification number used for special applications in restricted environments, defined by the local GS1 Member Organisation (e.g., restricted within a country, company, industry). They are allocated by GS1 for either internal use by companies or to GS1 Member Organisations for assignment based on business needs in their country (e.g., variable measure product identification, couponing).
Retail consumer trade item	The trade item intended to be sold to the end consumer at retail Point-of-Sale. They are identified with a GTIN-13, GTIN-12, or GTIN-8 using an EAN/UPC Symbol.
Retailer Zero-Suppression Code	A group of ID numbers (separate from Local Assigned Codes), that enable the use of UPC-E Bar Codes in a closed system environment (not for open supply chain applications).
Returnable Asset	A reusable entity owned by a company that is used for transport and storage of goods. Identified with a GRAI.
RFID	See Radio Frequency Identification
RFID reader	Also known as an Interrogator or a reader, a Radio Frequency Identification reader communicates via radio waves with RFID tags and delivers the information in a digital format to a computer system.
RFID tag	A microchip attached to an antenna that sends data to an RFID reader. The RFID tag contains a unique serial number, and can also contain additional data. RFID tags can be active, passive or semi-passive tags.

Term	Definition
scanner	An electronic device to read bar code symbols and convert them into electrical signals understandable by a computer device.
Separator Character	Function 1 Symbol Character used to separate certain concatenated Element Strings, dependent on their positioning in the GS1 Bar Code Symbols.
serial number	(1) A code, numeric or alphanumeric, assigned to an individual instance of an entity for its lifetime. Example: Microscope model AC-2 with serial number 1234568 and microscope model AC-2 with serial number 1234569. A unique individual item may be identified with the combined Global Trade Item Number (GTIN) and serial number. (2) Specific instance of the Object Class being tagged.
Serial Reference	A component of the Serial Shipping Container Code (SSCC) assigned by the owner of the GS1 Company Prefix to create a unique SSCC.
Serial Shipping Container Code	The GS1 Identification Key used to identify logistics units. The key is comprised of an Extension digit, GS1 Company Prefix, Serial Reference, and Check Digit.
Serialized Global Location Number (SGLN )	GLN plus AI (254) extension component (used in the EPC data structure).
Service Reference	A component of the Global Service Relation Number (GSRN) assigned by the owner of the GS1 Company Prefix to create a unique GSRN.
Single Shipping / Consumer Trade Item	A retail consumer trade item that is one to a carton (e.g. a bicycle or a television).
special characters	Special characters are designated by the symbology specification. For GS1-128 Symbology the special characters are the last 7 characters of codes sets A and B or the last 3 characters for code set C.
SSCC	See Serial Shipping Container Code
standard trade item grouping	A standard composition for a trade item(s) that is not intended for Point-of-Sale scanning. They are identified with a unique GTIN-14, GTIN-13, or GTIN-12.
substrate	The material on which a bar code symbol is printed.
supplier	The party that produces, provides, or furnishes an item or service.
symbol	The combination of symbol characters and features required by a particular symbology, including Quiet Zone, Start and Stop Characters, data characters, and other auxiliary patterns, which together form a complete scannable entity; an instance of a symbology and a data structure.
symbol character	A group of bars and spaces in a symbol that is decoded as a single unit. It may represent an individual digit, letter, punctuation mark, control indicator, or multiple data characters.
Symbol Check Character	A symbol character or set of bar/space patterns included within a GS1-128 or GS1 DataBar Symbol, the value of which is used by the bar code reader for the purpose of performing a mathematical check to ensure the accuracy of the scanned data. It is not shown in Human Readable Interpretation. It is not input to the bar code printer and is not transmitted by the bar code reader.
Symbol Contrast	An ISO 15416 parameter that measures the difference between the largest and smallest reflectance values in a Scan Reflectance Profile (SRP).
symbology	A defined method of representing numeric or alphabetic characters in a bar code; a type of bar code.
symbology element	A character or characters in a bar code symbol used to define the integrity and processing of the symbol itself (e.g., start and stop patterns). These elements are symbology overhead and are not part of the data conveyed by the bar code symbol.

Term	Definition
symbology identifier	A sequence of characters generated by the decoder (and prefixed to the decoded data transmitted by the decoder) that identifies the symbology from which the data has been decoded.
tag	See RFID tag.
trade item	Any item (product or service) upon which there is a need to retrieve pre-defined information and that may be priced, or ordered, or invoiced at any point in any supply chain.
trade measures	Net measures of Variable Measure Trade Items as used for invoicing (billing) the trade item.
transponder	A radio transmitter-receiver that is activated by a predetermined signal. RFID tags are sometimes referred to as transponders.
truncation	Printing a symbol shorter than the symbology specification's minimum height recommendations. Truncation can make the symbol difficult for an operator to scan.
U.P.C. Company Prefix	A special representation of a GS1 Company Prefix constructed from a U.P.C. Prefix and a Company Number. The U.P.C. Company Prefix is only used to create GTIN-12, Coupon-12, RCN-12, and VMN-12, which are encoded in a UPC-A Bar Code Symbol.
U.P.C. Prefix	A special representation of the GS1 Prefixes '00 – 09' with the leading zero removed. Used when representing the GTIN-12, Coupon-12, RCN-12, and VMN-12 in a UPC-A Bar Code Symbol.
Unit Load	One or more transport packages or other items contained on a platform making them suitable for transport, stacking, and storage as a unit.
unrestricted distribution	Signifies that such system data may be applied on goods to be processed anywhere in the world without restraint as to such things as country, company, and industry.
UPC-A Bar Code Symbol	A bar code symbol of the EAN/UPC Symbology that encodes GTIN-12, Coupon-12, RCN-12, and VMN-12.
UPC-A Composite Symbology	The GS1 Composite Symbology that utilises a UPC-A Bar Code Symbol as the linear component.
UPC-E Bar Code Symbol	A bar code symbol of the EAN/UPC Symbology representing a GTIN-12 in six explicitly encoded digits using zero-suppression techniques.
UPC-E Composite Symbology	The GS1 Composite Symbology that utilises a UPC-E Bar Code Symbol as the linear component.
Variable Measure Number (VMN)	A Restricted Circulation Number to identify variable measure products for scanning at Point of Sale. It is defined per GS1 Member Organisation rules in their country (see VMN-12 and VMN-13).
Variable Measure Trade Item	An item always produced in the same pre-defined version (e.g., type, design, packaging) that may be sold at any point in the supply chain, which either may vary in weight/size by its nature or which may be traded without a pre-defined weight/size/length.
VMN-12	The 12-digit Restricted Circulation Number encoded in UPC-A Symbols to allow scanning of variable measure products at Point of Sale. It is defined per target market specific rules that are associated with U.P.C. Prefix 2.
VMN-13	The 13-digit Restricted Circulation Number encoded in EAN-13 Symbols to allow scanning of variable measure products at Point of Sale. It is defined per target market specific rules that are associated with GS1 Prefixes 20 through 29.
Weight check digit	See Measure verifier-digit

Term	Definition
wide-to-narrow ratio	The ratio between the wide elements and the narrow elements in a bar code symbology, such as ITF-14, which has two different element widths.
X-dimension	The specified width of the narrow element in a bar code symbol.

## 8.2. GS1 Abbreviations

Abbreviation	Term
ADC	Automatic Data Capture
AI	Application Identifier
AIDC	Automatic Identification and Data Capture
ANSI	American National Standards Institute
DPM	Direct Part Marking
EAN	EAN International, now called GS1
EDI	Electronic Data Interchange
EPC	Electronic Product Code
FNC1	Function 1 Symbol Character
GDD	Global Data Dictionary
GDSN	Global Data Synchronization Network
GDTI	Global Document Type Identifier
GIAI	Global Individual Asset Identifier
GLN	Global Location Number
GPC	Global Product Classification
GRAI	Global Returnable Asset Identifier
GSMP	Global Standards Management Process
GSRN	Global Service Relation Number
GTIN	Global Trade Item Number
ISBN	International Standard Book Number
ISO	International Organisation for Standardisation
ISSN	International Standard Serial Number
LAC	Local Assigned Code
RCN	Restricted Circulation Number
RF	Radio Frequency
RFID	Radio Frequency Identification
RSS	Reduced Space Symbology
RZSC	Retailer Zero-Suppression Code.
VMN	Variable Measure Number

### 8.3. Legacy (Retired) Terms

When terms are replaced or retired by GS1, they are maintained within this section for a minimum of five years. The legacy terms are supplied to point GS1 stakeholders to new terminology. The period of five years ensures harmonization with external standards bodies whose standards make normative reference to the GS1 General Specifications.

Legacy Term	Current Term
auxiliary pattern	See auxiliary guard pattern
Clear Area	See Quiet Zone
Contrast	See Symbol Contrast
DUN-14 (Despatch Unit Number)	See GTIN-14
EAN	See GS1
EAN International	See GS1 Global Office
EAN Member Organisation	See GS1 Member Organisation
EAN.UCC Company Prefix	See GS1 Company Prefix
EAN.UCC Prefix	See GS1 Prefix
EAN.UCC XML	See GS1 XML
EAN/UCC-8 Data Structure	See GTIN-8
EAN/UCC-8 Identification Number	See GTIN-8
EAN/UCC-12 Data Structure	See GTIN-12, Coupon-12, RCN-12, and VMN-12
EAN/UCC-12 Identification Number	See GTIN-12, GLN, GDTI, Coupon-12, RCN-12, and VMN-12
EAN/UCC-13 Data Structure	See GTIN-13, Coupon-13, RCN-13, and VMN-13
EAN/UCC-13 Identification Number	See GTIN-13, GLN, GDTI, Coupon-13, RCN-13, and VMN-13
EAN/UCC-14 Data Structure	See GTIN-14
EAN/UCC-14 Identification Number	See GTIN-14
Interleaved 2 of 5	See ITF-14 Symbol
Item Number	See Item Reference
Item Reference Number	See Item Reference
LAC (Locally Assigned Code)	No longer used.
Light Margin	See Quiet Zone
Light Margin Indicator	See Quiet Zone Indicator
Location Number	See Global Location Number
Manufacturer's ID	See GS1 Company Prefix
Manufacturer's Number	See GS1 Company Prefix
Number System Character	See U.P.C. Prefix
Numbering Organisation (NO)	See GS1 Member Organisation
Packaging Indicator	See Indicator
Packaging Type	See Extension digit
printability gauge	See Print Gain Gauge
print gain/loss	See bar gain/loss

Legacy Term	Current Term
Reduced Space Symbology	GS1 DataBar Symbology
RSS Composite Symbology Family	GS1 DataBar Composite Symbology Family
RSS Expanded Bar Code Symbol	GS1 DataBar Expanded Symbol
RSS Expanded Composite Symbology	GS1 DataBar Expanded Composite Symbology
RSS Expanded Stacked Bar Code Symbol	GS1 DataBar Expanded Stacked Symbol
RSS Expanded Stacked Composite Bar Code Symbol	GS1 DataBar Expanded Stacked Composite Symbology
RSS Limited Bar Code symbol	GS1 DataBar Limited Symbol
RSS Limited Composite Symbology	GS1 DataBar Limited Composite Symbology
RSS Omnidirectional	GS1 DataBar Retail POS Family
RSS-14 Bar Code Symbol	GS1 DataBar Omnidirectional Symbol
RSS-14 Composite Symbology	GS1 DataBar Composite Symbology
RSS-14 Stacked Bar Code Symbol	GS1 DataBar Stacked Symbol
RSS-14 Stacked Composite Symbology	GS1 DataBar Stacked Composite Symbology
SCC-14	Global Trade Item Number
SSCC Serial Number	See Serial Reference
standard numbering structures	See data structure
Symbol Control Character	See symbology element
UCC	GS1 US
UCC Company Prefix	See U.P.C. Company Prefix
UCC Prefix	See U.P.C. Prefix
UCC-12 Data Structure	See GTIN-12, GDTI-12, Coupon -12, RCN-12, and VMN-12
UCC-12 Identification Number	See GTIN-12, GDTI-12, Coupon -12, RCN-12, and VMN-12
Uniform Code Council, Inc	GS1 US
Variable Measure Retail Item	See RCN